

TOSHIBA

UNINTERRUPTIBLE POWER SYSTEMS



XT

1800 Series

2400 VA

3 Year
Warranty

Reliability in motion[®]

- True On-Line Double Conversion, PWM Input PF Correction UPS
- Isolation Transformer for Complete Power Conditioning
- High Overload and CF for Motor Type Loads
- Auto-Restart and Cold Start Features for Remote Location
- Increased Input Voltage Window +10% to -40% for Increased Battery Life
- Four (4) Fan Speed for Optimum Cooling and Noise Reduction
- Compactly Designed, Both Rectifier and Inverter Utilize 36.5 kHz IGBT Technology
- Intelligent Charger with Rapid Charge in only 3.5 hours to 90%
- Wide Input Frequency Window for Complete Generator Compatibility

1800 Series 2400 VA

CAPACITY		2400 VA
INPUT	Voltage	Single-Phase 208/240 Vac (3 Wire Input/L-L,G)
	Voltage Range	144 V to 264 V (+10% to -40%)
	Frequency	50/60 Hz Auto-Sensing
	Synchronization Window	± 3 Hz
	Power Factor	Greater than 0.95
OUTPUT	Voltage	120/208/240 Vac (3 Wire Input/L-L,G)
	Capacity (VA/W)	2400 VA*/1680 W*
	Voltage Regulation	± 3%
	Voltage Distortion	Less than 5% THD at Full Non-Linear Load. Less than 3% THD at Full Linear Load.
	Step Load	± 9% Max. from 100% to 0% or from 0% to 100% Linear Load
	Rated Current at 240 V	9.6 A
	Overload Capacity	125% for 1 Minute; 150% for 30 Seconds
	Crest Factor	2.5 at Full Load
	Frequency	50/60 Hz Auto-Sensing (± 0.5 Hz)
	Wave Form	Sine Wave, Zero Transfer Time
	Load Power Factor	0.7
	Efficiency AC to DC to AC	80%
	BATTERY	DC Voltage
Backup Time (Full Load)		7 Minutes
Battery Type		Energys NPX-35FR Lead Acid 9 Ah/12 V
	Number of Batteries	Two (2) Strings in Parallel, Four (4) Batteries per String
PHYSICAL	Interface	RS-232, Dry Contact, External Battery Connectors
	Line Cord and Receptacles	Hardwired (With Optional Line Cord & Receptacle Panels)
	Dimensions	254 W x 686 D x 597 H mm (10 W x 27 D x 23.5 H in.)
	Weight	77 kg (170 lbs.)
OPTION	Network Interface Card	RemotEye®II Part #: RMTI-INT-R4
	Environmental Monitoring Device	Part #: RMTI-EMD-HT
ENVIRONMENT	Operating Ambient Temperature	0 to 40° C (32 to 104° F)
	Humidity	30% to 90%, Non-Condensing
	Audible Noise	Less than 50 dB Normal and Battery Modes
	Altitude	1000 m (3000 ft) Above Sea Level
CONFORMANCE	Regulatory Approvals	UL1778, CUL, CE, FCC Class A, IEEE 587, ANSI/C62.41, ISO 9001, ISO 140001, NEMA/PE1-1993
	Warranty	Three (3) Years on Electronics Two (2) Years Full Replacement on Batteries (See Toshiba Warranty Policy for Full Details)

*208/240 Transformer Models Result in 5% Derating

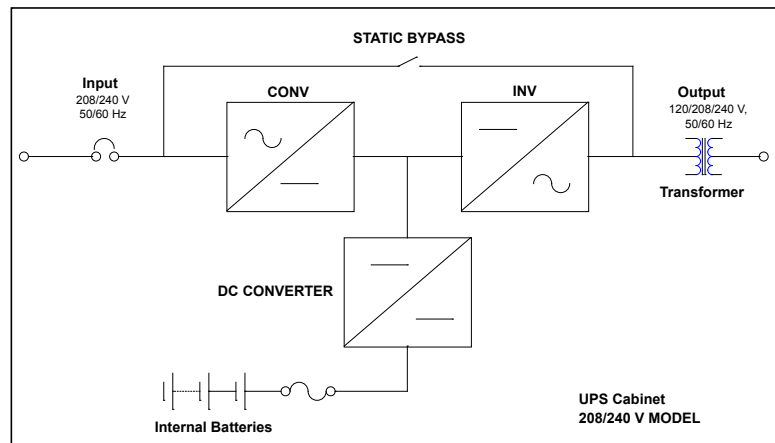

UPS ADJUSTABLE SPEED DRIVES MOTORS CONTROLS INSTRUMENTATION PLC

TOSHIBA

Available Through:

TOSHIBA INTERNATIONAL CORPORATION

INDUSTRIAL DIVISION

13131 West Little York Road, Houston, Texas 77041

Tel 713/466-0277 Fax 713/466-8773

US 800/231-1412 Canada 800/872-2192 Mexico 001/800/527-1204

www.toshiba.com/ind

Copyright 10/2007

