

UNINTERRUPTIBLE POWER SYSTEMS



XT

1600EP Series

3.6 to 22 KVA Single-Phase

3 Year
Warranty

- True On-Line, Double Conversion UPS
- Input Power Factor > 0.95
- Input Current THD < 5%
- Wide Input Voltage Window +10% to -30%
- Wide Input Frequency Window 45 to 65 Hz
- 0.85 Output Power Factor; More Usable Watts per KVA
- Electronic Power Factor Correction for 100% Generator Compatibility
- Hot-Swappable Battery Packs and Cooling Fans
- Internal Isolation Transformer
- Digital LCD
- Programmable Front Keypad
- External Battery Connector

Reliability *in motion*[®]

1600EP Series 3.6 to 22 KVA UPS

Capacity	RoHS 3.6 KVA (3.1 KW)	3.6 KVA (3.1 KW)	6 KVA (5.1 KW)	8 KVA (6.8 KW)	10 KVA (8.5 KW)	14 KVA (11.9 KW)	18 KVA (15.3 KW)	22 KVA (18.7 KW)
Topology	True On-Line, Double Conversion; IGBT Power Factor Corrected Input; Internal Isolation Transformer							
Certifications	UL 1778, CUL, CE, FCC Class A, IEEE 587, ANSI/C62.41, ISO 9001, ISO 14001, NEMA/PE1-1993							
Input Characteristics								
Input Voltage	Single-Phase 208/240 VAC (Three-Wire Input/L-L, G); 230 VAC (Three-Wire Input/L, N, G), +10% -30%							
Input Frequency	45 to 65 Hz (Auto-Sensing)							
Input Power Factor	> 0.95 For All Loads							
Input Current THD	< 5% (Even for 100% Non-Linear Loads)							
AC Input Breaker Rating	30 A		50 A	60 A	63 A	100 A	100 A	125 A
Battery Characteristics								
Battery Type	Valve Regulated Lead Acid; Flame Retardant (9.0 Amp Hr)							
Backup Time (Fully Charged)	7 Minutes	10 Minutes	7 Minutes	7 Minutes	5 Minutes	7 Minutes	5 Minutes	3 Minutes
Recharge Time	0.85 Power Factor; 77° F; Approximately 30% More Runtime for Output Power Factor of 0.7 (Triple Backup Time at ½ Load)							
DC Link	144 VDC		216 VDC				288 VDC	
Output Characteristics								
Output Voltage	Single-Phase 240/208/120 VAC (Four-Wire Output/L-L, N, G) 230 VAC (Three-Wire Output L, N, G)							
Output Voltage Regulation	±3 Max.; ±1% Typical							
Output Frequency	50/60 Hz; ±0.5 Hz/1.0 Hz/1.5 Hz (Factory or Authorized Service Center Selectable)							
Output Voltage THD	< 3% for Linear Load; 1% Typical							
Common Mode Noise	< 0.5 V RMS							
Rated-Load Power Factor	0.85 (0.6 to 1.0) Lag							
Efficiency (ac-dc-ac)	> than 85%							
Rated Output Current @ 240 V	15 A		25 A	33.3 A	41.6 A	58 A	75A	91.6 A
Maximum Peak Output Current	45 A		75 A	100 A	126 A	174 A	225 A	275 A
Overload Capacity	150% for 10 Seconds and 125% for 10 Minutes; Bypass 1000% for One Cycle							
Heat Generation (BTU/Hr)	1588		2610	3482	4352	6092	7832	9600
Mechanical Design								
Enclosure	Steel Enclosure; Complies with NEMA 1 and UL Type-1 Standard							
Enclosure Dimensions (HxWxD)	21" x 10" x 33"	27.5" x 10" x 33"		28.4" x 13" x 33.5"			39.1" x 17.5" x 34.8"	
Shipping Weight	325 lbs/147 kg	371 lbs/168 kg	395 lbs/179 kg	533 lbs/242 kg		835 lbs/379 kg	835 lbs/379 kg	835 lbs/379 kg
Battery Pack Size (HxWxD)	5" x 7.3" x 18.2" (Six Batteries of NPX-35 Per Pack)							
Battery Pack Quantity	Two		Three		Four		Eight	
Options								
RemotEyell	SNMP & WEB-Based Monitoring, Internal and External Modules Available							
Matching Battery Cabinet	Consult Factory							
Internal/Ext. Maintenance Bypass	Consult Factory							
Receptacle Panel & Line Cord	Consult Factory							
Warranty	3 Years on Electronics (UPS); 2 Years on Battery (See Toshiba Warranty Policy for Full Details)							

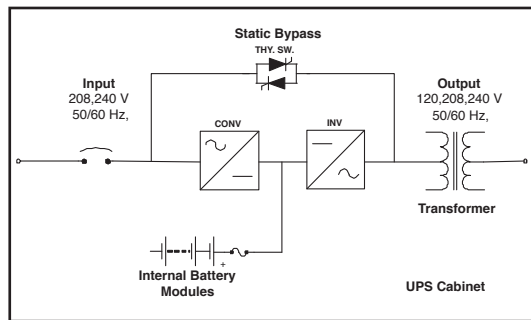

RemotEye II® (Option)

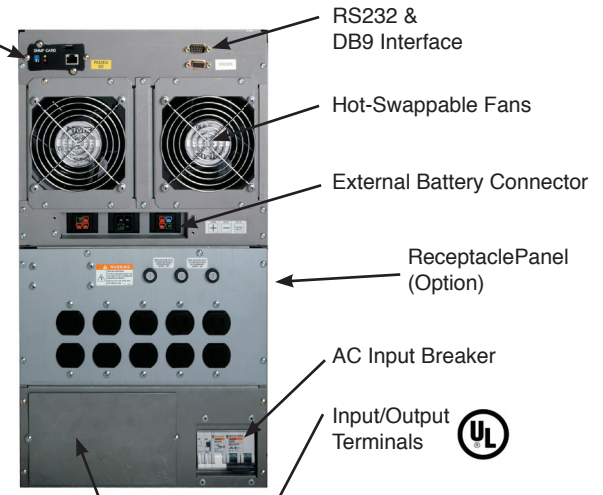

UPS ADJUSTABLE SPEED DRIVES MOTORS CONTROLS INSTRUMENTATION PLC

TOSHIBA

TOSHIBA INTERNATIONAL CORPORATION

INDUSTRIAL DIVISION

13131 West Little York Road, Houston, Texas 77041

Tel 713/466-0277 Fax 713/466-8773

US 800/231-1412 Canada 800/872-2192 Mexico 001/800/527-1204

www.toshiba.com/ind

Copyright 4/2008

Available Through:

