



Self-Contained & Split System Reverse Cycle Air Conditioners Models 05-07-10-12-16-18-24

General Description

Marvair's water source self-contained and split system reverse cycle air conditioners are designed for use in either fresh or salt water. These units are built in capacities of 5,000; 7,000; 10,000; 12,000; 16,000; 18,000 and 24,000 BTUH. The self-contained units are complete packaged units, factory charged and wired. The split systems are comprised of two parts, a condensing section comprised of the compressor section and the air handler section. Field installed refrigerant tubing and wiring connects the two sections.

Units are available for operation on 115V, 60 Hz; 208/230V, 60 Hz and 220/240V, 50 Hz. The units are built using R-22, R407C or R410A refrigerant. Both R407C and R410A are environmentally friendly, non-ozone depleting and accepted for use throughout the European Community.

The reverse cycle air conditioners feature rotary and scroll compressors with a suction line accumulator and high and low refrigerant pressure switches. The coaxial tube-in-tube condenser is constructed of corrosion resistant cupronickel water tubing and copper refrigerant tubing.

To ensure years of dependable performance, the units feature:

- A stainless steel base pan with multiple condensate drain openings allows the rapid disposal of condensate. The base pan is embossed to add rigidity and to keep the components out of the condensate. An insulated pad minimizes movement and sound. On the split systems, the compressor section and the air handler are mounted in a stainless steel trays.
- Structural supports and control box constructed of superior corrosion resistant aluminum. The aluminum is primed and then a white heat cured polyester finish is applied for the optimum in durability and aesthetics.
- A five foot long (151 cm), heavy duty multiwire cable harness facilitates the remote mounting of the control box. This complete cable assembly seals all the wires into the harness to minimize the chance of corrosion.
- The evaporator coil is constructed of lanced fins and rifled copper tubing for optimum heat transfer. The coil has a baked polyester enamel finish - no paint - and is rated to 1,000 hours when tested to ASTM B117.
- A compact, motorized impeller type blower moves the conditioned air quietly and efficiently through duct work. Backward curved, corrosion resistant centrifugal fans feature extremely long blades for high efficiency and low noise. Maintenance free ball bearings never need oiling.

All units are built to the requirements of UL standard 484, 7th Edition. Marvair® is an ISO 9001-2000 registered company. All self contained and split systems units (unless designated otherwise) meet applicable ABYC and US Coast Guard regulations, CE directives and all applicable Air Conditioning and Refrigeration Institute standards.



SPB16RCB-00



DEAH07RCB & CUB07RCB



Installation

Installation on both self contained and split system units is simplified with a readily accessible terminal strip for both the power and control (low voltage) wiring. The control box is located on the side of the self contained units and in the compressor section of the split systems. However, the control box can be easily mounted on the opposite side or on the top of the unit or even remotely mounted on a bulkhead. A five foot (151 cm) multiwire cable harness provides a durable and quick electrical connection between the unit and the control box. Condensate line ports (5/8" nylon tube) on both ends and both sides of the base pan facilitate the drain line connections. Factory provided hold-down clamps are included. On the split system units, threaded refrigerant connections on both the compressor section and the air handler eliminate the need for a braising. The compressor section is shipped with a holding charge and, in many cases, no additional refrigerant is required.

Thermostats

All units can be controlled by either the MachAir II OLED or the MachAir I thermostat/controller. The MachAir II OLED and the MachAir I thermostat/controller display shows whether the unit is in the heating or cooling or fan only or dehumidification mode, set point temperature (°F or °C), cabin temperature (°F or °C) and fan indicator. The cooling or heating can be selected manually or the Auto mode selects whichever is required automatically. The fan speed can be controlled automatically or manually. Includes wall mounted controller/display. See the MachAir II OLED Product Data Sheet for complete information on the MachAir II OLED thermostat/controller.

Accessories

Accessories are required and ordered separately.

- Sea Water Pump Kit.
- Air duct, supply grille(s) and return grille.
- Plumbing fittings.
- Thermostat/controller.

Model Identification - Self-Contained Units

S	P	•	••	••	•	•	••
S = Marine	Refrigerant P = R22 C = 407C A = R410A	Controller B = Electronic Control Board	Nominal Capacity 05 = 5,000 BTUH 07 = 7,000 BTUH 10 = 10,000 BTUH 12 = 12,000 BTUH 16 = 16,000 BTUH 18 = 18,000 BTUH 24 = 24,000 BTUH	System Type AC = Air Conditioner RC = Reverse Cycle	Voltage A = 208/230V, 1ø, 60 Hz B = 115V, 1ø, 60 Hz F = 220/240V, 1ø, 50 Hz	Orientation* L = Left Hand R = Right Hand	Electronic Thermostat/ Controller M2 = MachAir II Board

Note: 18,000 BTUH models are only available with 60 Hz units.

Model Identification - Split System Condensing Section

C	•	•	••	••	•	••
Marine	Refrigerant P = R22 C = 407C A = R410A	Controller B = Control Board	Nominal Capacity 07 = 7,000 BTUH 10 = 10,000 BTUH 12 = 12,000 BTUH 16 = 16,000 BTUH 18 = 18,000 BTUH 24 = 24,000 BTUH	System Type AC = Air Conditioner RC = Reverse Cycle	Voltage A = 208/230V, 1ø, 60 Hz B = 115V, 1ø, 60 Hz F = 220/240V, 1ø, 50 Hz	Electronic Thermostat/ Controller M2 = MachAir II Board

Note: 18,000 BTUH models are only available with 60 Hz units.

Model Identification - Split System Air Handler Section

DEAH	••	••	•	•
Direct Expansion Air Handler	Nominal Capacity 07 = 7,000 BTUH 10 = 10,000 BTUH 12 = 12,000 BTUH 16 = 16,000 BTUH 18 = 18,000 BTUH 24 = 24,000 BTUH	System Type AC = Air Conditioner RC = Reverse Cycle	Voltage A = 208/230V, 1ø, 60 Hz B = 115V, 1ø, 60 Hz F = 220/240V, 1ø, 50 Hz	Orientation* L = Left Hand R = Right Hand

* When looking at the compressor from the end of the unit, if the coil is on your right side, the unit is a right handed unit. If the coil is on your left, it is a left handed unit.

Water Flow Chart

Minimum Water Flow* for Reverse Cycle Systems	
Model (BTUH)	Minimum Water Flow at the Unit
5,000	1.4 GPM / 5.3 LPM
7,000	2.0 GPM / 7.6 LPM
10,000	2.9 GPM / 11.0 LPM
12,000	3.5 GPM / 13.3 LPM
16,000	4.7 GPM / 17.8 LPM
18,000	5.25 GPM / 19.9 LPM
24,000	7.0 GPM / 26.5 LPM

* Based upon 85°F (29.5°C) inlet water measured at the inlet of the unit.

Air Flow and Grille Chart

Self Contained Unit or Air Handler	Nominal Air Flow CFM/m ³ per Hour	Minimum Opening for Return Air Grille (in ² /cm ²)	Minimum Opening for Supply Air Grille(s) (in ² /cm ²)	Minimum Hose Size (in/cm)	Marvair P/N for Blower to Hose Adapters	Outside Diameter of Hose Adapter (in/cm)
5,000	150/255	64/415	32/210	4/10.2	Not required. Blower has 4" (10.2cm) round diameter opening.	Not required. Blower has 4" (10.2cm) round diameter opening.
7,000	250/425	100/645	40/260	5/12.7	90134 ¹ (5" round hose adapter)	4-3/4" (12cm)
10,000	300/510	100/645	60/390	5 or 6*/12.7 or 15.2*	90134 (5" round hose adapter) or 90135 ¹ (6" round hose adapter)	4-3/4" (12 cm) or 5-3/4" (14.6 cm)
12,000	360/612	140/900	70/450	6/15.2	90135 ¹ (6" round hose adapter)	5-3/4" (14.6 cm)
16,000	385/654	168/1,110	84/540	6 or 7*/15.2 or 17.8*	90135 (6" round hose adapter) or 90136 ¹ (7" round hose adapter)	5-3/4" (14.6 cm) or 6-3/4" (17.15cm)
18,000	420/714	168/1,110	84/540	7/17.8*	90136 ¹ (7" round hose adapter)	6-3/4" (17.15cm)
24,000	700/1,190	240/1,550	192/1,240	8* or 10/20.3* or 25.4	90568 ² (8" oval hose adapter)	10" x 4" (25.4 x 10.2 cm)

* Use larger size if duct run is greater than 10 ft. (3 meters).
¹ Shipped standard with unit.
² Two adapters are shipped with each two ton unit.

Performance/Electrical Data for Self-Contained Units - Models SP, 60 Hz, R-22 Refrigerant

Model Number	Capacity (BTUH)	Voltage (VAC)	Freq. (Hz.)	Run Amps ¹	Starting Amps ¹	Minimum Circuit Ampacity	Maximum Breaker (Amp)	Weight (Lbs)	Refrig.
SP*05B	5,000	115	60	5.33	18.7	6.5	10	41	R-22
SP*07B	7,000	115	60	6.67	23.4	8.1	15	55	R-22
SP*07A	7,000	230	60	3.4	11.8	4.1	10	55	R-22
SP*10B	10,000	115	60	7.5	26.4	9.1	15	63	R-22
SP*10A	10,000	230	60	5.0	17.5	6.1	10	63	R-22
SP*12B	12,000	115	60	9.8	34.5	12.0	20	66	R-22
SP*12A	12,000	230	60	5.3	18.6	6.5	10	66	R-22
SP*16B	16,000	115	60	12.0	42.0	14.6	20	67	R-22
SP*16A	16,000	230	60	6.8	23.6	8.2	15	67	R-22
SP*18B	18,000	115	60	16.0	56.1	19.6	30	68	R-22
SP*18A	18,000	230	60	8.0	27.9	9.7	15	68	R-22

See Performance/Electrical Data for Self-Contained units - Model SA24, 60 Hz, R410A Refrigerant.

Performance/Electrical Data for Self-Contained Units - Models SP, 50 Hz, R-22 Refrigerant

Model Number	Capacity (BTUH)	Voltage (VAC)	Freq. (Hz.)	Run Amps ¹	Starting Amps ¹	Minimum Circuit Ampacity	Maximum Breaker (amp)	Weight (kg)	Refrig.
SP*05F	5,000	220	50	2.9	10.1	3.5	10	19	R-22
SP*07F	7,000	220	50	3.8	13.4	4.7	10	25	R-22
SP*10F	10,000	220	50	4.8	16.8	5.9	10	29	R-22
SP*12F	12,000	220	50	6.1	21.3	7.5	10	30	R-22
SP*16F	16,000	220	50	7.3	25.4	8.9	15	30	R-22

See Performance/Electrical Data for Self-Contained units - Model SA24, 60 Hz, R410A Refrigerant.

Performance/Electrical Data for Self-Contained Units - Models SC, 50 Hz, R-407C Refrigerant

Model Number	Capacity (BTUH)	Voltage (VAC)	Freq. (Hz.)	Run Amps ¹	Starting Amps ¹	Minimum Circuit Ampacity	Maximum Breaker (amp)	Weight (kg)	Refrig.
SC*05F	5,000	220	50	2.9	10.1	3.5	10	19	R-407C
SC*07F	7,000	220	50	3.5	12.1	4.2	10	25	R-407C
SC*10F	10,000	220	50	4.8	16.8	5.9	10	29	R-407C
SC*12F	12,000	220	50	6.1	21.3	7.5	10	30	R-407C
SC*16F	16,000	220	50	7.3	25.4	8.9	15	30	R-407C

See Performance/Electrical Data for Self-Contained units - Model SA24, 60 Hz, R410A Refrigerant.

¹ Amps will vary with actual voltage, inlet water temperature and inlet air temperature and humidity. Amps will be approximately 50% higher in the heating mode.

Performance/Electrical Data for Self-Contained Units - Model SA24, R-410A Refrigerant

Model Number	Capacity (BTUH)	Voltage (VAC)	Freq. (Hz.)	Run Amps ¹	Starting Amps ¹	Minimum Circuit Ampacity	Maximum Breaker (amp)	Weight (kg)	Refrig.
SAB24RCF	24,000	220/240	50	13.34	16.00	16.5	25.0	50	R-410A
SAB24RCA	24,000	208/230	60	14.30	19.20	17.7	30.0	50	R-410A

Dimensional Data - Self-Contained Model 05 (inches & mm)



LEFT HAND UNIT

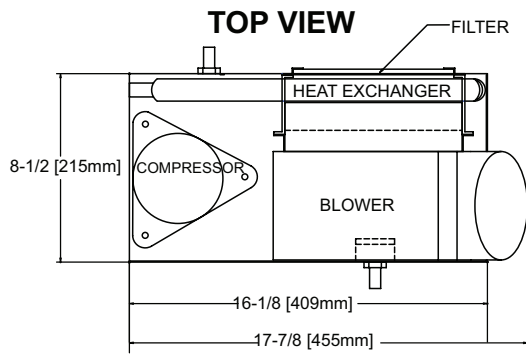

REMOTE CONTROL BOX

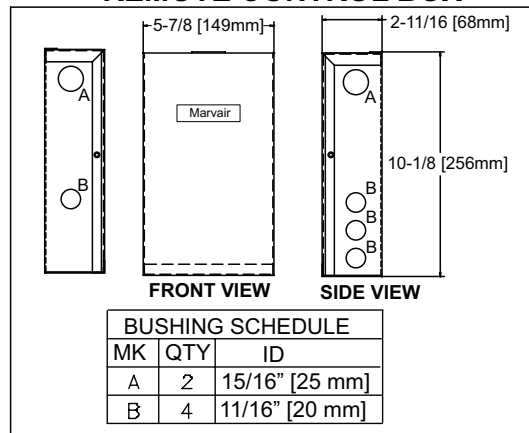

BUSHING SCHEDULE		
MK	QTY	ID
A	2	15/16" [25 mm]
B	4	11/16" [20 mm]

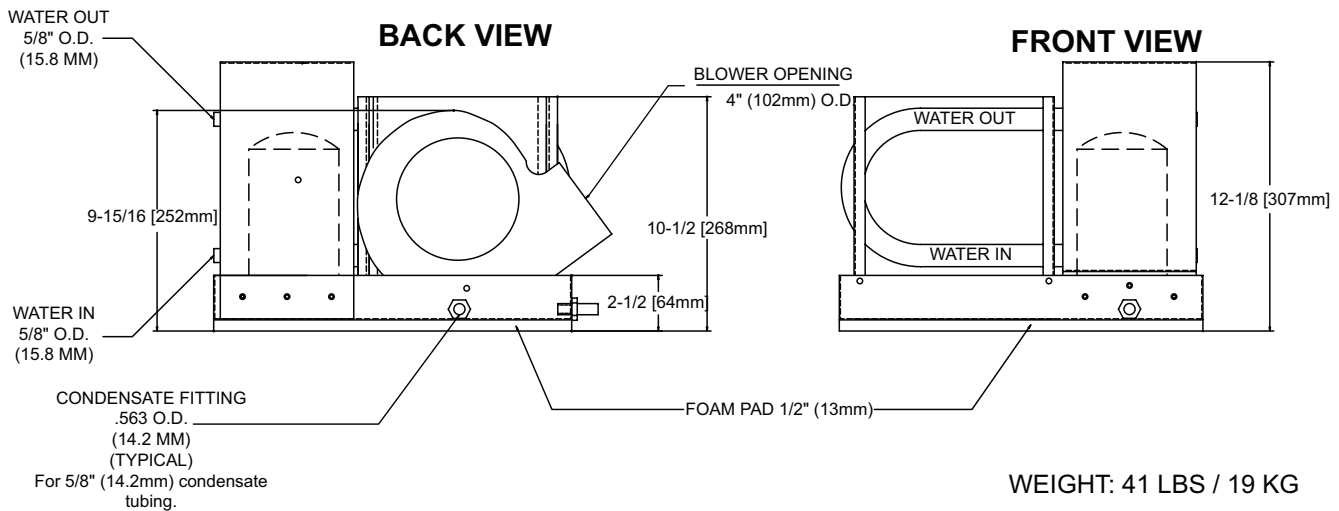

WEIGHT: 41 LBS / 19 KG

NOTE: THE ELECTRICAL CONTROL BOX FOR ALL 5,000 MODELS IS ALWAYS REMOTELY MOUNTED.

Dimensional Data - Self-Contained Models 07-10-12-16-18 (inches & mm)

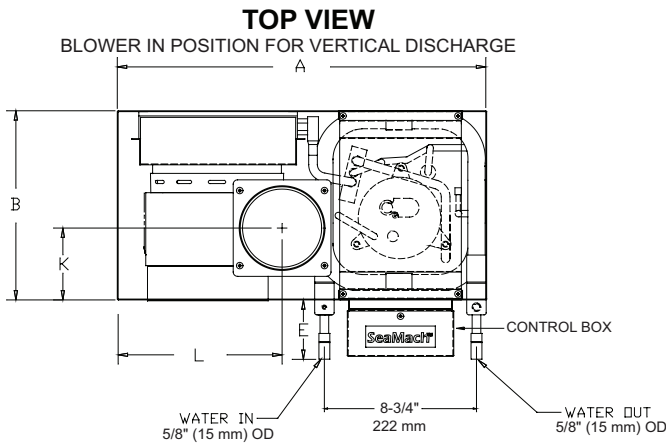

RIGHT HAND UNIT

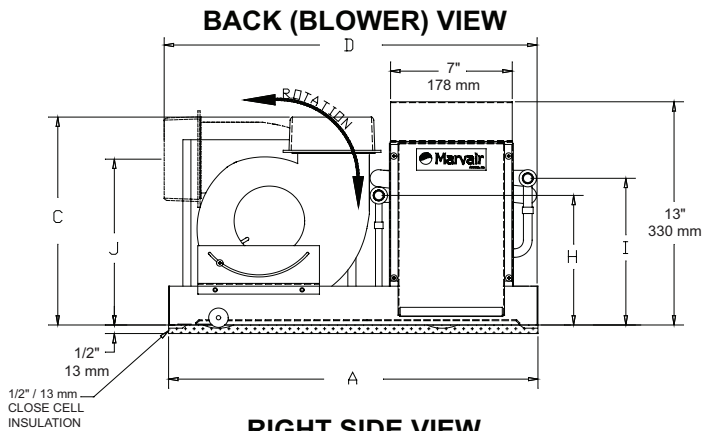

FRONT (EVAPORATOR) VIEW

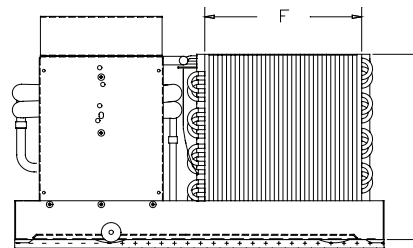

RIGHT SIDE VIEW

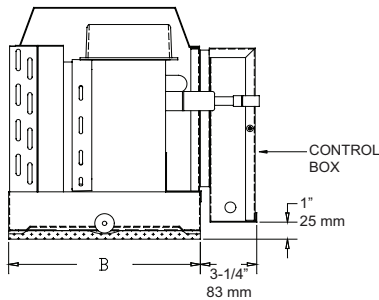

LEFT SIDE VIEW

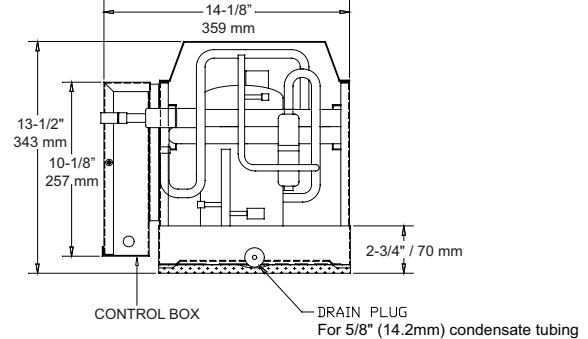

DIMS	07	10	12	16	18
A	21-1/4" (540mm)	22-7/8" (581mm)	22-7/8" (581mm)	23-3/4" (603mm)	23-3/4" (603mm)
B	11" (279mm)	11" (279mm)	11" (279mm)	11" (279mm)	11" (279mm)
C	12-1/4" (311mm)	13-5/8" (346mm)	13-7/8" (352mm)	13-5/8" (346mm)	13-5/8" (346mm)
D	22-3/8" (568mm)	24-1/2" (622mm)	24-3/4" (629mm)	25-3/4" (654mm)	25-3/4" (654mm)
E	3-1/2" (89mm)	3-3/8" (86mm)	3-3/8" (86mm)	3-3/8" (86mm)	3-3/8" (86mm)
F	9-1/8" (232mm)	11" (279mm)	11" (279mm)	11-1/2" (292mm)	11-1/2" (292mm)
G	10-7/8" (276mm)	13" (330mm)	13" (330mm)	13-1/8" (333mm)	13-1/8" (333mm)
H	7-1/2" (191mm)	7" (178mm)	7" (178mm)	6-3/4" (171mm)	6-3/4" (171mm)
I	9" (229mm)	9-3/4" (248mm)	9-3/4" (248mm)	9-3/8" (238mm)	9-3/8" (238mm)
J	10" (254mm)	10-3/4" (273mm)	10-3/4" (273mm)	10-1/2" (267mm)	10-1/2" (267mm)
K	4" (102mm)	3-1/2" (89mm)	3-1/2" (89mm)	3-1/2" (89mm)	3-1/2" (89mm)
L	9" (229mm)	10-3/8" (264mm)	10-3/8" (264mm)	10-1/8" (257mm)	10-1/8" (257mm)
WT.	55 Lbs (25 kg)	63 Lbs (29 kg)	66 Lbs (30 kg)	67 Lbs (30 kg)	68 Lbs

CONTROL BOX DIMENSIONS - 11 x 3-1/2 x 6-1/4" (279 x 79 x 159 mm)

Dimensional Data - Self-Contained Model 24 (inches & mm)

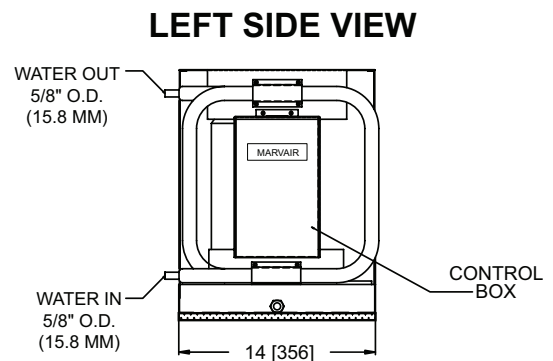
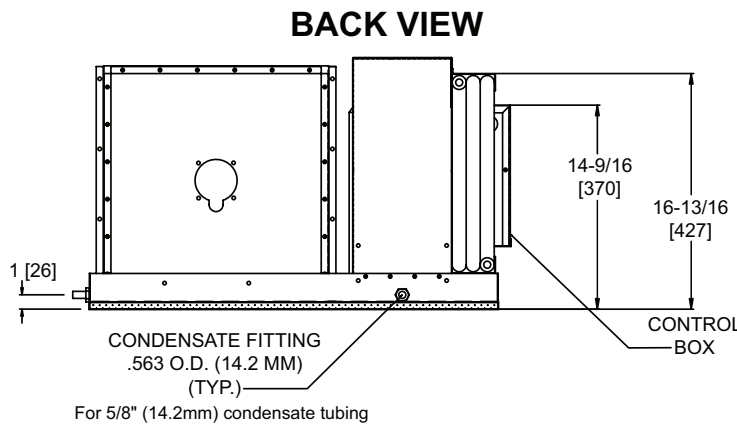
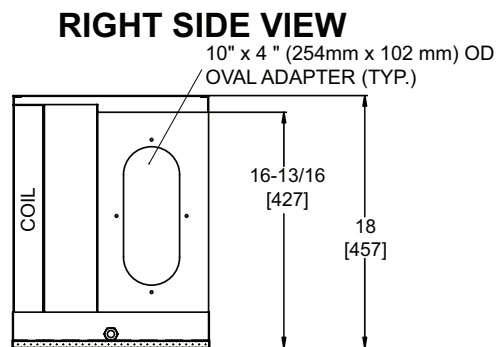
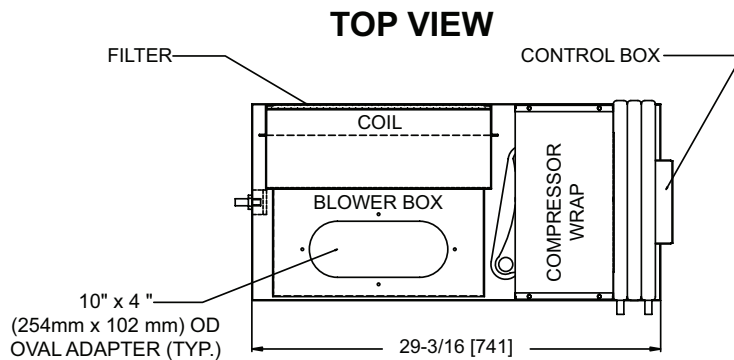
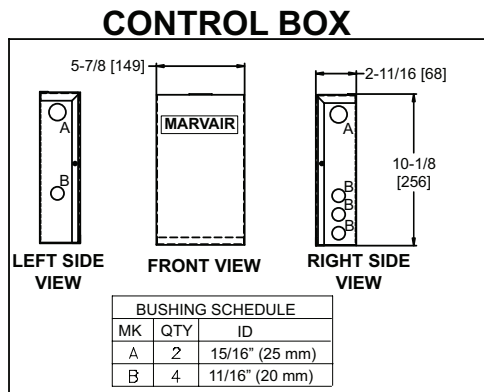

WEIGHT: 111 LBS / 50 KG

There are two conditioned air outlet openings, one on the top and one on the right side. Each opening is a 9-7/8" x 4" (251mm x 102mm) oval opening. An oval adapter, Marvair part number 91568, should be used as a transition to duct on each opening. This adapter has an outside diameter of 10" x 4" (254 mm x 102 mm). For optimum performance, both openings must be used. Insufficient air flow can cause ice to form on the evaporator coil in the cooling mode and premature activation of the circuit breaker in the heating mode.

Performance/Electrical Data for Split System Condensing Section, Model CP, 60 Hz, R-22 Refrigerant

Model Number	Capacity (BTUH)	Voltage (VAC)	Freq. (Hz.)	Run Amps ¹	Starting Amps ^{1,2}	Minimum Current Amps	Maximum Breaker (Amp)	Weight (Lbs/kg)
CPB/M07RCB	7,000	115	60	6.7	23.4	8.1	15	39/18
CPB/M07RCA	7,000	230	60	3.4	11.8	4.1	10	39/18
CPB/M10RCB	10,000	115	60	7.5	26.4	9.1	15	45/20
CPB/M10RCA	10,000	230	60	5.0	17.5	6.1	10	45/20
CPB/M12RCB	12,000	115	60	9.8	34.5	12.0	20	47/21
CPB/M12RCA	12,000	230	60	5.3	18.6	6.5	10	47/21
CPB/M16RCB	16,000	115	60	12.0	42.0	14.6	20	47/21
CPB/M16RCA	16,000	230	60	6.8	23.6	8.2	15	47/21
CPB/M18RCB	18,000	115	60	16.0	56.1	19.6	30	48/22
CPB/M18RCA	18,000	230	60	8.0	27.9	9.7	15	48/22

See Performance/Electrical Data for Split System Condensing Section, Model CA, 60 Hz, R-410A Refrigerant.

Performance/Electrical Data for Split System Condensing Section, Model CC, 50 Hz, R-22 Refrigerant

Model Number	Capacity (BTUH)	Voltage (VAC)	Freq. (Hz.)	Run Amps ¹	Starting Amps ^{1,2}	Minimum Current Amps	Maximum Breaker (amp)	Weight (kg)
CPB/M07RCF	7,000	220	50	3.8	13.4	4.7	10	18
CPB/M10RCF	10,000	220	50	4.8	16.8	5.9	10	20
CPB/M12RCF	12,000	220	50	6.1	21.3	7.5	10	21
CPB/M16RCF	16,000	220	50	7.3	25.4	8.9	15	21

See Performance/Electrical Data for Split System Condensing Section, Model CA, 60 Hz, R-410A Refrigerant.

Performance/Electrical Data for Split System Condensing Section, Model CC, 50 Hz, R-407c Refrigerant

Model Number	Capacity (BTUH)	Voltage (VAC)	Freq. (Hz.)	Run Amps ¹	Starting Amps ^{1,2}	Minimum Current Amps	Maximum Breaker (amp)	Weight (kg)
CCB/M07RCF	7,000	220	50	3.5	12.1	4.2	10	18
CCB/M10RCF	10,000	220	50	4.8	16.8	5.9	10	20
CCB/M12RCF	12,000	220	50	6.1	21.3	7.5	10	21
CCB/M16RCF	16,000	220	50	7.3	25.4	8.9	15	21

See Performance/Electrical Data for Split System Condensing Section, Model CA, 60 Hz, R-410A Refrigerant.

Performance/Electrical Data for Split System Condensing Section - Model CA24, R-410A Refrigerant

Model Number	Capacity (BTUH)	Voltage (VAC)	Freq. (Hz.)	Run Amps ¹	Starting Amps ¹	Minimum Circuit Ampacity	Maximum Breaker (amp)	Weight (kg)	Refrig.
CAB24RCF	24,000	220/240	50	13.34	16.00	16.5	25.0	36	R-410A
CAB24RCA	24,000	208/230	60	14.30	19.20	17.7	30.0	50	R-410A

Electrical Data - Model DEAH, 50 Hz

Unit	Capacity (BTUH)	Volts	Freq. (Hz.)	Full Load Amps ³	Air Flow (m ³ /hr)	Weight (kg)
DEAH07RCF	7,000	240	50	0.44	360	10
DEAH10RCF	10,000	240	50	0.58	495	11
DEAH12RCF	12,000	240	50	0.58	495	12
DEAH16RCF	16,000	240	50	0.86	580	12
DEAH24RCF	24,000	240	50	0.86	968	20

F = 220/240V

¹ Amps will vary with actual voltage, inlet water temperature and inlet air temperature and humidity. Amps are approximately 50% higher in the heating mode.

² Condensing unit amps include one air handler.

³ Amps will vary with actual voltage.

Electrical Data - Model DEAH, 60 Hz

Unit	Capacity (BTUH)	Volts	Freq. (Hz.)	Full Load Amps ³	Air Flow (CFM)	Weight (Lbs/kg)
DEAH07RCB	7,000	115	60	0.85	250	22/10
DEAH07RCA	7,000	230	60	0.44	250	22/10
DEAH10RCB	10,000	115	60	1.14	300	25/11
DEAH10RCA	10,000	230	60	0.58	300	25/11
DEAH12RCB	12,000	115	60	1.14	360	26/12
DEAH12RCA	12,000	230	60	0.58	360	26/12
DEAH16RCB	16,000	115	60	1.75	385	27/12
DEAH16RCA	16,000	230	60	0.86	385	27/12
DEAH18RCB	18,000	115	60	1.95	400	27/12
DEAH18RCA	18,000	230	60	0.94	400	27/12
DEAH24RCA	24,000	230	60	0.86	700	44/20

B = 115V A = 230V

³ Amps will vary with actual voltage.

Split System Air Handler Models 07-10-12-16-18 Dimensional Data (inches/mm) & Weight (lbs/kg)

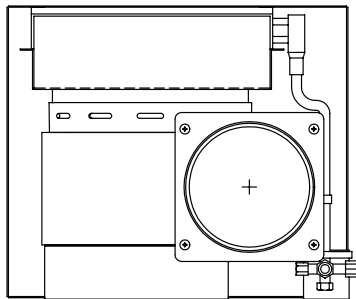

TOP VIEW

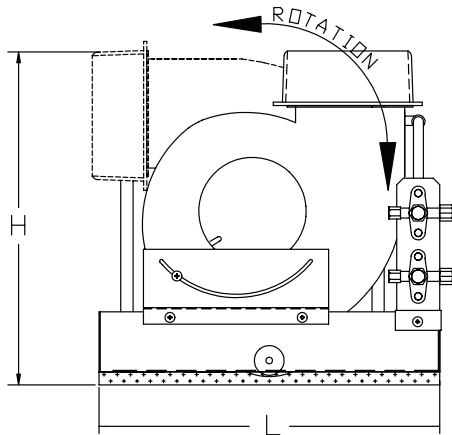

FRONT VIEW

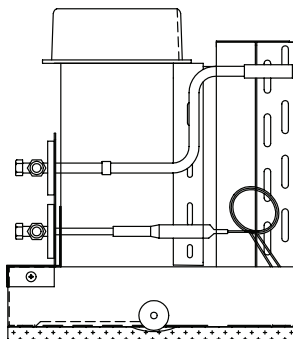

SIDE VIEW

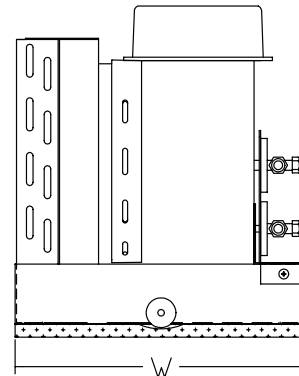

SIDE VIEW

CONDENSATE FITTING
.563 O.D.
(14.2 MM)
(TYPICAL)
For 5/8" (14.2mm)
condensate tubing.

Model	Dimensions - inches(mm)			Weight Lbs(kg)
	H	L	W	
DEAH07RC	11.50 (292)	12.88 (327)	11.03 (280)	22 (10)
DEAH10RC	13.50 (343)	14.88 (378)	11.03 (280)	25 (11)
DEAH12RC	13.50 (343)	14.88 (378)	11.03 (280)	26 (12)
DEAH16RC	13.50 (343)	15.38 (391)	11.03 (280)	27 (12)
DEAH18RC	13.50 (343)	15.38 (391)	11.03 (280)	27 (12)

Note: 18,000 BTUH models are only available with 60 Hz units.

Split System Condensing Section Models 07-10-12-16-18

Dimensional Data (inches/mm) & Weight (lbs/kg)

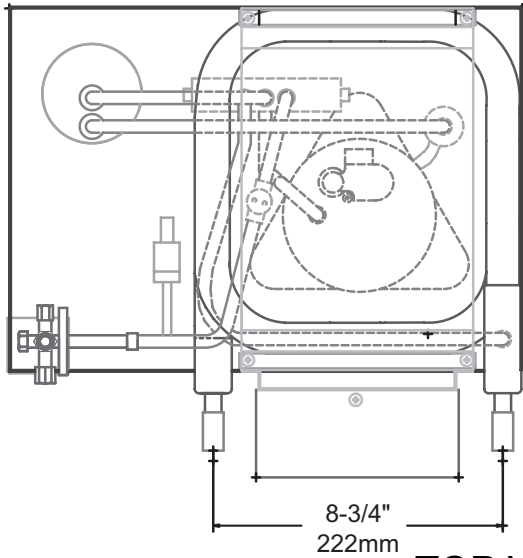

TOP VIEW

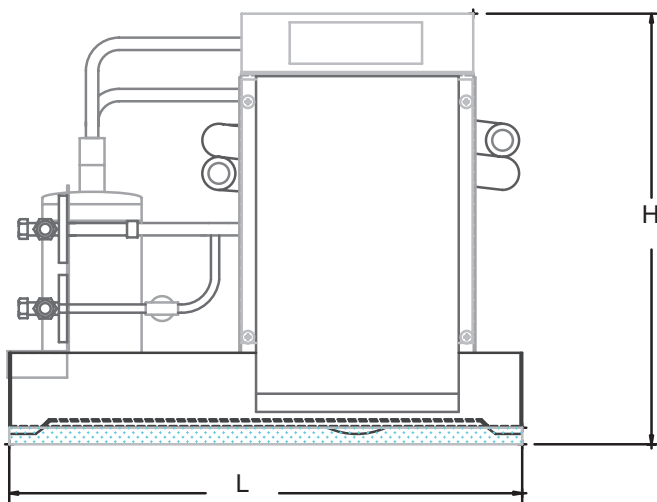

FRONT VIEW

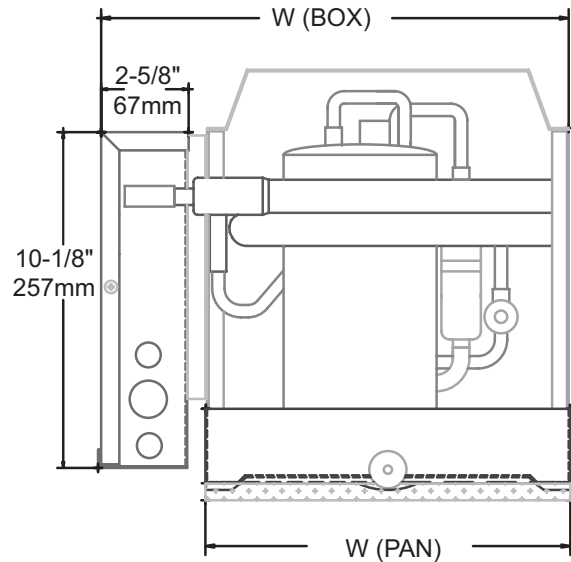

SIDE VIEW

Model	Dimensions - inches (mm)				Weight Lbs(kg)
	H	L	W (Pan)	W (Box)	
07	13.13 (333)	15.50(394)	11.03 (280)	14.28(363)	39 (18)
10	13.13 (333)	15.50(394)	11.03 (280)	14.28(363)	45 (20)
12	13.13 (333)	15.50(394)	11.03 (280)	14.28(363)	47 (21)
16	13.13 (333)	15.50(394)	11.03 (280)	14.28(363)	47 (21)
18	13.13 (333)	15.50(394)	11.03 (280)	14.28 (363)	48 (22)

Unit Capacity (Btu/Hr)	Refrigerant Conn. (Male Flare) - in(mm)	
	Liquid	Suction
7,000	1/4" (6.35)	3/8" (9.525)
10,000	1/4" (6.35)	3/8" (9.525)
12,000	1/4" (6.35)	3/8" (9.525)
16,000	1/4" (6.35)	1/2" (12.7)
18,000	1/4" (6.35)	1/2" (12.7)

Note: 18,000 BTUH models are only available with 60 Hz units.

Split System Condensing Section Model 24 Dimensional Data (in./mm)

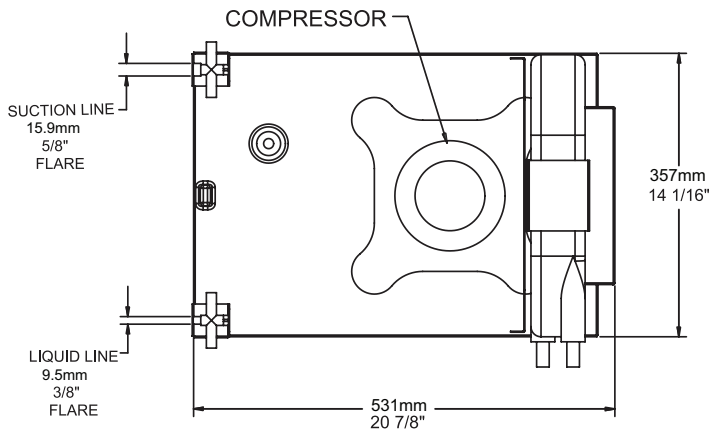

TOP VIEW

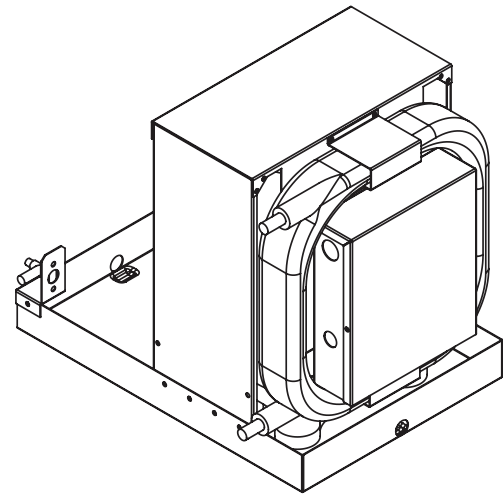

ISOMETRIC VIEW

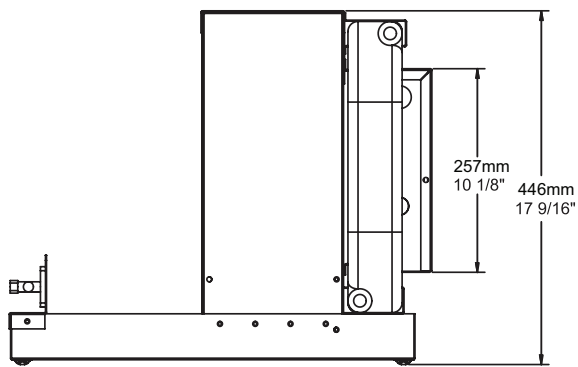

FRONT VIEW

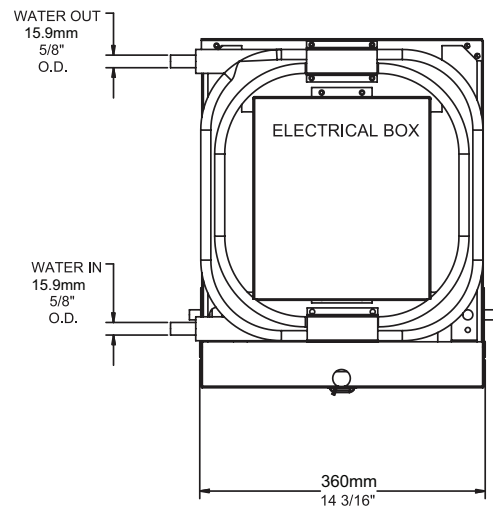

SIDE VIEW

WEIGHT: 79 LBS / 36 KG



Split System Air Handler Section Model 24 Dimensional Data (in./mm)

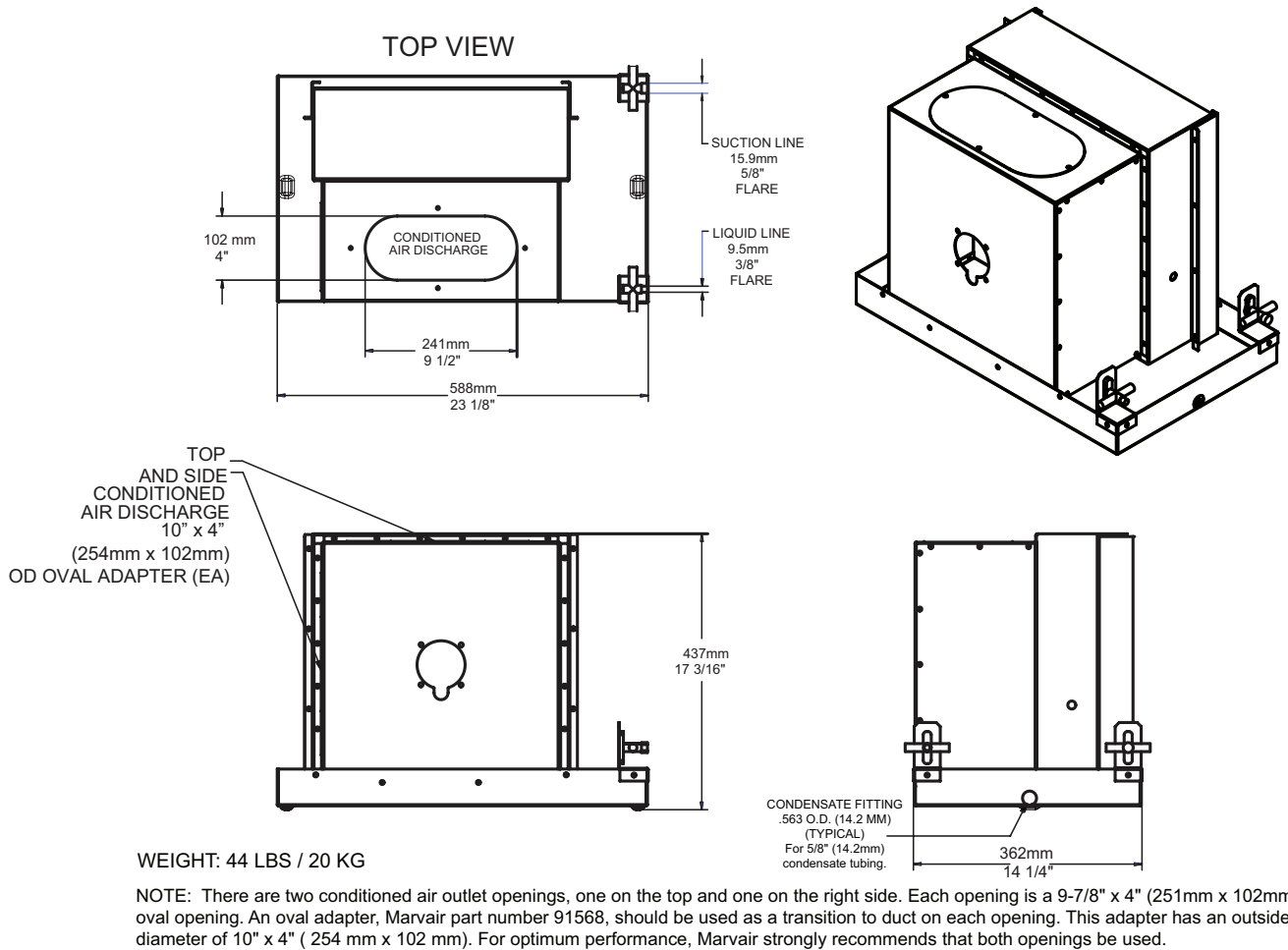

Please consult the Marvair® website at www.marvair.com for the latest product literature. Complete installation instructions are in the SeaMach™ Installation and Service Manual. Detailed dimensional data is available upon request. A complete warranty statement can be found in each product's Owner's Manual, on our website or by contacting Marvair at 229-273-3636. As part of the Marvair continuous improvement program, specifications are subject to change without notice.

P.O. Box 400 • Cordele, Georgia 31010
156 Seedling Drive • Cordele, Georgia 31015
Ph: 229-273-3636 • Fax: 229-273-5154
Email: marvair@airxcel.com
www.marvair.com



Marvair Marine UK
Unit B8 • Arena Business Centre • Holyrood Close
Poole, Dorset BH17 7FL.
+44 1202 606405
www.marvair.co.uk