

NCPP

Nickel Cadmium Pocket Plate



Single Cell
Dimensional and Electrical Data



H2LNIFE

HBL NIFE is the largest manufacturer of specialised batteries in India. HBL's vision is to organize India's engineering talent into globally competitive manufacturing strength. The business strategy continues to focus on engineering intensive industrial products rather than brand driven or commodity products. Specialised batteries and electronics for Aviation, Defence, Railways, Telecom and Heavy industry have been the focus.

HBL NIFE has an unusually strong commitment to R&D and has developed a capability to network Indian and foreign talent to overcome technology gaps in scientifically innovative ways . HBL NIFE has also been equally successful in working with foreign licenses when such licenses do not restrict export market access. The only such license currently in place is from DAUG

Among the many such products, of particular interest (reflecting the level of R&D Capability) are:

- Lithium, Thermal and Reserve Batteries.
- Torpedo Batteries
- Aircraft Sintered Plate Nicad Batteries
- Aircraft Batteries in Pure Lead and Tin technologies.

The company can offer its customers the most appropriate technology based on their requirement, covering Nickel cadmium, Silver zinc, Lead acid and Lithium batteries. Chargers for rechargeable batteries are also manufactured in both TR and SMR versions from 24V to 220V. The company has sales of about US \$ 50 million and very substantial design and development capabilities.

Designed to perfection, built to last

The unique constructional features of the HBL NIFE's Nickel Cadmium Pocket Plate Battery, makes it superior to the rest of its kind

Construction

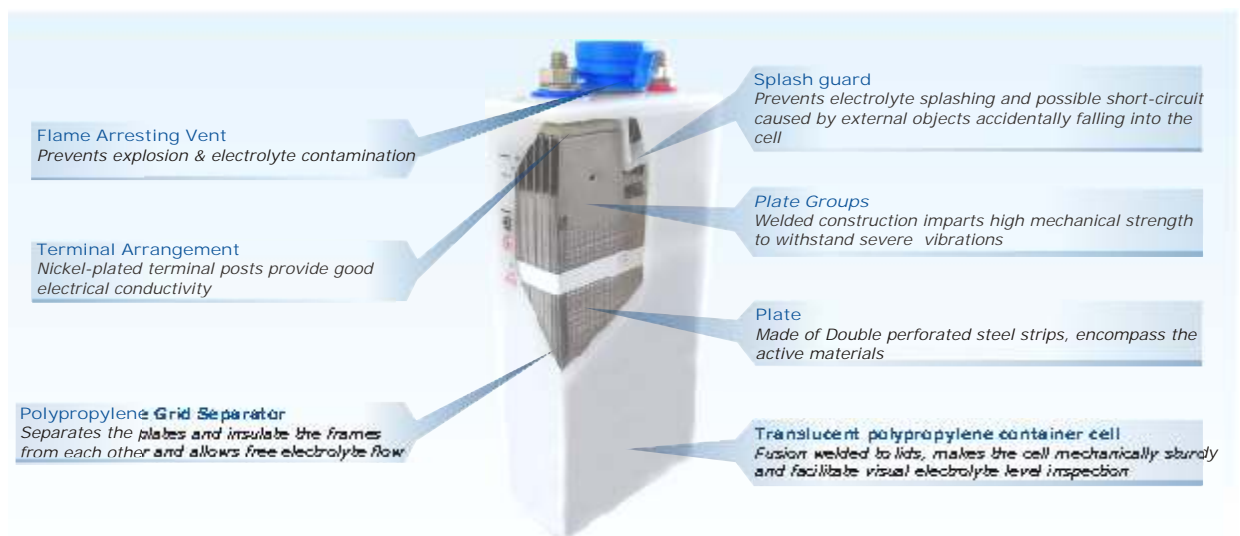

Product Range

Three type series -KPH, KPM and KPL with different performance characteristics and covering a wide capacity range, permit selection of an optimum battery for a given application.

KPH range has

- Thin plates
- Excellent high rate performance

KPM range has

- Optimised plate thickness
- Ideal for medium discharge periods

KPL range has

- Thick plates
- Provides large capacity power reserves for long durations

Outstanding Advantages of HBL NIFE power systems Ltd's batteries are:

- Highest reliability among all battery systems.
- Operation over a wide temperature range.
- Unsurpassed resistance to electrical and mechanical abuse.
- Minimal maintenance.
- Long service life.
- Long shelf life.
- Very good charge retention.
- Quick charging.

Built in Reliability

The first and most reliable electrode design for Nickel Cadmium batteries is the pocket plate construction. Active materials are encapsulated between folded steel strip which are perforated from both sides. This double perforated pattern gives the plate an effective surface area 30% greater than what was previously attainable. Maximum effective area means maximum load capabilities. These strips are housed in a steel frame. The alkaline electrolyte filled-in reacts only with the plate and not with the steel structure, thereby eliminating the chance of internal mechanical failure. Hence, the battery is strong enough to withstand virtually any shock or vibration

The pocket plate group separators are made of a wear resistant polypropylene / ABS material which is chemically inert. The HBL NIFE power systems Ltd's cells are available in containers of polypropylene. The polypropylene container can withstand mechanical stresses, shocks and vibrations. It performs in temperature extremes without losing strength, insulates well, resists corrosion. Furthermore, the translucent nature of polypropylene allows visual check of electrolyte level for ease in maintenance. The cells are also available in Structural Foam molded containers for mobile applications.



Governing Standards

HBL NIFE Power systems Ltd's batteries conform to Indian Standard IS 10918 and other relevant international standards such as IEC, DIN, BS, KS, etc

Batteries are tested by third party, Canadian Standards Association for IEC 60623 standards.

System Guarantee

We have a full-fledged power electronics division which designs & manufactures chargers of any rating and configurations, in both thyristorised and SMR technologies. This will give our customers the added advantage of single point solution and system guarantee.

Electrical Performance Characteristics

Nickel Cadmium pocket plate batteries are the most reliable and rugged batteries available today. They can withstand to a great extent any type of abuse like overcharge, deep discharge, even accidental reverse charge and can be stored in any state of charge

Charging

These batteries can be charged by any known method and available charger like taper charger, constant current charger, constant voltage charger, float or trickle charger. A dual mode charger which will recharge a discharged battery at constant current and high voltage boost mode and then bring it to constant potential float mode at low voltage to keep the battery in fully charged condition, is ideal to get the best performance.

Current limit - max. $0.2C_5$ A

Float voltage - 1.40 to 1.42 V/Cell

However, if single mode charger is already available, like in old systems or in locomotives, the battery can be operated with constant voltage charging.

Recommended Charging voltage setting: 1.45 to 1.50V / Cell.

Discharge Performance

The rated AH capacity of a nickel cadmium battery is defined as the Ampere Hours available at 5 hour rate of discharge to 1.00V/Cell end voltage at 20°C after charging at constant current of $0.2C_5$ rate for 8 hours.

However, the performance or the actual AH available from particular cell type depends on the rate of discharge, cell end voltage, temperature, type of charging, state of charge, etc.

The discharge performance table in this document gives the amperes available for the cell type for different durations and cell end voltages. These data are true for standard charge of constant current at $0.2C_5$ rate for 8 hours, rest and temperature conditions and for new cells.

Also discharge performance data after long term float with constant voltage charging is provided.

If the actual conditions differ from standard, the expected performance will be different. Our application engineering department will provide the details and further help you in selecting the optimum battery type for your requirement.

H Range

Cell dimensions

Cell Type	C ₂₀ AH	Cell Dimensions in mm			Cell connection bolt size	Container size reference	Volume of electrolyte above plates(cc)	Approximate cell weight (kgs)
		Height	Width	Length 1.2V L(1)				
KPH 10 P	10	229	86	46	M8	S1	100	1.4
KPH 12 P	12	229	86	46	M8	S1	100	1.5
KPH 16 P	16	229	86	61	M8	S2	130	1.8
KPH 20 P	20	239	134	44	M8	S3	140	2.2
KPH 24 P	24	289	134	59	M10	S4	200	3.3
KPH 30 P	30	289	134	59	M10	S4	200	3.6
KPH 35 P	35	289	134	59	M10	S4	200	4.0
KPH 40 P	40	289	134	59	M10	S4	200	4.2
KPH 45 P	45	374	134	74	M10	S5	420	5.4
KPH 50 P	50	374	134	74	M10	S5	420	5.8
KPH 57 P	57	374	134	74	M10	S5	420	6.3
KPH 63 P	63	374	134	74	M10	S5	420	6.5
KPH 69 P	69	374	134	74	M10	S5	420	6.7
KPH 76 P	76	374	134	74	M10	S5	420	7.0
KPH 80 P	80	374	134	74	M10	S5	420	7.2
KPH 92 P	92	391	134	101	2 X M10	S6	580	9.4
KPH 103 P	103	391	134	101	2 X M10	S6	580	9.8
KPH 110 P	110	391	134	101	2 X M10	S6	580	10.2
KPH 120 P	120	391	134	101	2 X M10	S6	580	10.8
KPH 130 P	130	417	159	106	2 X M10	S7	740	11.8
KPH 145 P	145	417	159	106	2 X M10	S7	740	12.5
KPH 155 P	155	417	159	106	2 X M10	S7	740	13.2
KPH 170 P	170	417	159	106	2 X M10	S7	740	14.0
KPH 185 P	185	443	163	166	2 X M10	S8	1210	19.0
KPH 210 P	210	443	163	166	2 X M10	S8	1210	20.0
KPH 230 P	230	443	163	166	2 X M10	S8	1210	20.8
KPH 240 P	240	443	163	166	2 X M10	S8	1210	21.6
KPH 255 P	255	443	163	166	2 X M10	S8	1210	22.0
KPH 265 P	265	443	163	166	2 X M10	S8	1210	22.4

Cell Performance H range

Performance fully charged with constant current charging

Final Voltage: 1.14V/cell

Available amperes at +20° C ± 5° C

Cell Type	C _s Ah	Hours						Minutes					Seconds				
		8	5	3	2	1.5	1	30	20	15	10	5	90	60	30	5	1
KPH 10 P	10	1.17	1.86	3.03	4.43	5.72	8.10	12.1	14.8	16.7	19.6	24.8	32.8	39.0	45.2	56.4	59.1
KPH 12 P	12	1.40	2.23	3.63	5.32	6.87	9.70	14.5	17.7	20.0	23.5	29.7	39.4	46.8	54.3	67.7	71.0
KPH 16 P	16	1.87	2.97	4.85	7.10	9.17	13.0	19.4	23.7	26.7	31.3	39.7	52.5	62.4	72.3	90.2	94.6
KPH 20 P	20	2.34	3.71	6.06	8.87	11.4	16.2	24.2	29.6	33.3	39.1	49.6	65.6	78.0	90.4	113	118
KPH 24 P	24	2.81	4.45	7.27	10.6	13.7	19.4	29.0	35.5	40.0	47.0	59.5	78.7	93.6	109	135	142
KPH 30 P	30	3.51	5.57	9.09	13.3	17.2	24.3	36.3	44.3	50.0	58.7	74.3	98.4	117	136	169	177
KPH 35 P	35	4.10	6.49	10.6	15.5	20.0	28.4	42.4	51.7	58.3	68.5	86.7	115	136	158	197	207
KPH 40 P	40	4.68	7.42	12.1	17.7	22.9	32.4	48.4	59.1	66.7	78.3	99.1	131	156	181	226	237
KPH 45 P	45	5.27	8.35	13.6	20.0	25.8	36.5	54.5	66.5	75.0	88.0	112	148	175	203	254	266
KPH 50 P	50	5.85	9.28	15.1	22.2	28.6	40.5	60.5	73.9	83.4	97.8	124	164	195	226	282	296
KPH 57 P	57	6.67	10.6	17.3	25.3	32.6	46.2	69.0	84.3	95.0	112	141	187	222	258	321	337
KPH 63 P	63	7.37	11.7	19.1	27.9	36.1	51.0	76.2	93.1	105	123	156	207	246	285	355	373
KPH 69 P	69	8.07	12.8	20.9	30.6	39.5	55.9	83.5	102	115	135	171	226	269	312	389	408
KPH 76 P	76	8.89	14.1	23.0	33.7	43.5	61.9	92.0	112	127	149	188	249	296	344	429	449
KPH 80 P	80	9.52	15.1	24.4	35.5	45.8	64.8	96.8	118	133	157	198	262	312	362	451	473
KPH 92 P	92	10.9	17.3	27.9	40.8	52.6	74.5	111	136	153	180	228	302	359	416	519	544
KPH 103 P	103	12.3	19.5	31.4	45.7	59.0	83.4	125	152	172	202	255	338	402	466	581	609
KPH 110 P	110	13.1	20.8	33.6	48.8	63.0	89.1	133	163	183	215	273	361	429	497	620	650
KPH 120 P	120	14.3	22.7	36.6	53.2	68.7	97.2	145	177	200	235	297	394	468	543	677	710
KPH 130 P	130	15.5	24.6	39.7	57.5	74.4	104	153	186	209	242	306	398	461	528	623	645
KPH 145 P	145	17.3	27.4	44.2	64.1	82.9	116	171	208	233	270	341	444	514	589	695	719
KPH 155 P	155	18.4	29.3	47.3	68.5	88.7	124	183	222	249	289	365	474	550	629	743	769
KPH 170 P	170	20.2	32.1	51.9	75.1	97.2	136	200	243	273	317	400	520	603	690	815	844
KPH 185 P	185	22.0	35.0	56.4	81.8	106	148	218	265	297	345	435	566	656	751	887	918
KPH 210 P	210	25.0	39.7	64.1	92.8	120	168	247	301	338	391	494	643	745	853	1007	1042
KPH 230 P	230	27.4	43.5	70.2	102	132	184	271	329	370	429	541	704	816	934	1103	1141
KPH 240 P	240	28.6	45.4	73.2	106	137	192	283	344	386	447	565	734	852	974	1151	1191
KPH 255 P	255	30.3	48.2	77.8	113	146	204	300	365	410	475	600	780	905	1035	1223	1265
KPH 265 P	265	31.5	50.1	80.8	117	152	212	312	379	426	494	624	811	940	1076	1270	1315

Performance after long term floating with constant voltage charging

Final Voltage: 1.14V/cell

Available amperes at +20° C ± 5° C

Cell Type	C _s Ah	Hours						Minutes					Seconds				
		8	5	3	2	1.5	1	30	20	15	10	5	90	60	30	5	1
KPH 10 P	10	1.17	1.86	3.03	4.43	5.72	7.74	10.7	12.4	13.6	15.3	18.4	23.2	27.6	32.0	39.9	41.8
KPH 12 P	12	1.40	2.23	3.63	5.32	6.87	9.28	12.9	14.9	16.3	18.3	22.0	27.8	33.1	38.4	47.8	50.2
KPH 16 P	16	1.87	2.97	4.85	7.10	9.17	12.4	17.2	19.9	21.7	24.4	29.4	37.1	44.1	51.1	63.8	66.9
KPH 20 P	20	2.34	3.71	6.06	8.87	11.4	15.5	21.5	24.8	27.2	30.5	36.8	46.4	55.1	63.9	79.7	83.6
KPH 24 P	24	2.81	4.45	7.27	10.6	13.7	18.6	25.8	29.8	32.6	36.6	44.2	55.7	66.2	76.8	95.7	100
KPH 30 P	30	3.51	5.57	9.09	13.3	17.2	23.2	32.2	37.2	40.8	45.8	55.1	69.6	82.7	96.0	120	125
KPH 35 P	35	4.10	6.49	10.6	15.5	20.0	27.1	37.6	43.4	47.6	53.4	64.3	81.2	96.3	112	140	146
KPH 40 P	40	4.68	7.42	12.1	17.7	22.9	30.9	42.9	49.6	54.3	61.1	73.5	92.8	110	128	159	167
KPH 45 P	45	5.27	8.35	13.6	20.0	25.8	34.8	48.3	55.8	61.1	68.7	82.8	104	124	144	179	188
KPH 50 P	50	5.85	9.28	15.1	22.2	28.6	38.7	53.7	62.1	67.9	76.3	92.0	116	138	160	199	209
KPH 57 P	57	6.67	10.6	17.3	25.3	32.6	44.1	61.2	70.8	77.4	87.0	105	132	157	182	227	238
KPH 63 P	63	7.37	11.7	19.1	27.9	36.1	48.7	67.6	78.2	85.6	96.1	116	146	174	202	251	263
KPH 69 P	69	8.07	12.8	20.9	30.6	39.5	53.4	74.1	85.6	93.7	105	127	160	190	221	275	289
KPH 76 P	76	8.89	14.1	23.0	33.7	43.5	59.1	81.6	94.3	103	116	140	176	210	243	303	318
KPH 80 P	80	9.52	15.1	24.4	35.5	45.8	61.9	85.9	99.3	109	122	147	186	221	256	319	335
KPH 92 P	92	10.9	17.3	27.9	40.8	52.6	71.2	98.7	114	125	140	169	213	254	294	367	385
KPH 103 P	103	12.3	19.5	31.4	45.7	59.0	79.7	111	128	140	157	190	239	284	330	411	431
KPH 110 P	110	13.1	20.8	33.6	48.8	63.0	85.1	118	137	149	168	202	255	303	352	439	460
KPH 120 P	120	14.3	22.7	36.6	53.2	68.7	92.8	129	149	163	183	221	278	331	384	478	502
KPH 130 P	130	15.5	24.6	39.7	57.5	74.4	99.3	136	156	170	189	227	281	326	373	441	456
KPH 145 P	145	17.3	27.4	44.2	64.1	82.9	111	152	174	190	211	253	314	364	416	491	509
KPH 155 P	155	18.4	29.3	47.3	68.5	88.7	118	162	186	203	225	271	335	389	445	525	544
KPH 170 P	170	20.2	32.1	51.9	75.1	97.2	130	178	204	223	247	297	368	426	488	576	596
KPH 185 P	185	22.0	35.0	56.4	81.8	106	141	193	223	242	269	323	400	464	531	627	649
KPH 210 P	210	25.0	39.7	64.1	92.8	120	160	219	253	275	305	367	454	527	603	712	737
KPH 230 P	230	27.4	43.5	70.2	102	132	176	240	277	301	334	402	498	577	660	780	807
KPH 240 P	240	28.6	45.4	73.2	106	137	183	251	289	315	349	419	519	602	689	813	842
KPH 255 P	255	30.3	48.2	77.8	113	146	195	266	307	334	371	445	552	640	732	864	895
KPH 265 P	265	31.5	50.1	80.8	117	152	202	277	319	347	385	463	573	665	761	898	930

Cell Performance H range

Performance fully charged with constant current charging

Final Voltage: 1.10V/cell

Available amperes at +20° C ± 5° C

Cell Type	C _s Ah	Hours						Minutes					Seconds				
		8	5	3	2	1.5	1	30	20	15	10	5	90	60	30	5	1
KPH 10 P	10	1.21	1.91	3.14	4.62	6.06	8.7	14.5	17.7	20.1	23.6	29.7	39.2	45.5	52.8	64.3	68.7
KPH 12 P	12	1.45	2.30	3.77	5.55	7.27	10.4	17.4	21.2	24.2	28.3	35.7	47.0	54.6	63.3	77.2	82.4
KPH 16 P	16	1.94	3.06	5.03	7.40	9.69	13.9	23.2	28.3	32.2	37.8	47.5	62.7	72.8	84.4	103	110
KPH 20 P	20	2.42	3.83	6.29	9.25	12.1	17.4	29.0	35.4	40.3	47.2	59.4	78.4	91.0	106	129	137
KPH 24 P	24	2.90	4.59	7.55	11.1	14.5	20.9	34.8	42.4	48.3	56.7	71.3	94.1	109	127	154	165
KPH 30 P	30	3.63	5.74	9.43	13.9	18.2	26.1	43.5	53.0	60.4	70.9	89.1	118	137	158	193	206
KPH 35 P	35	4.24	6.70	11.0	16.2	21.2	30.4	50.7	61.9	70.5	82.7	104	137	159	185	225	240
KPH 40 P	40	4.84	7.65	12.6	18.5	24.2	34.8	58.0	70.7	80.6	94.5	119	157	182	211	257	275
KPH 45 P	45	5.45	8.61	14.2	20.8	27.3	39.1	65.2	79.6	90.7	106	134	176	205	237	290	309
KPH 50 P	50	6.05	9.57	15.7	23.1	30.3	43.5	72.5	88.4	101	118	149	196	228	264	322	343
KPH 57 P	57	6.90	10.9	17.9	26.4	34.5	49.6	82.6	101	115	135	169	223	259	301	367	392
KPH 63 P	63	7.62	12.1	19.8	29.1	38.2	54.8	91.3	111	127	149	187	247	287	332	405	433
KPH 69 P	69	8.35	13.2	21.7	31.9	41.8	60.0	100	122	139	163	205	270	314	364	444	474
KPH 76 P	76	9.20	14.5	23.9	35.2	46.0	66.1	110	134	153	180	226	298	346	401	489	522
KPH 80 P	80	9.84	15.6	25.6	37.0	48.5	69.6	116	141	161	189	238	314	364	422	515	550
KPH 92 P	92	11.3	17.9	29.4	42.6	55.7	80.0	133	163	185	217	273	361	419	485	592	632
KPH 103 P	103	12.7	20.1	33.0	47.6	62.4	89.6	149	182	207	243	306	404	469	543	663	708
KPH 110 P	110	13.5	21.5	35.2	50.9	66.6	95.7	159	194	222	260	327	431	501	580	708	756
KPH 120 P	120	14.8	23.4	38.4	55.5	72.7	104	174	212	242	283	357	470	546	633	772	824
KPH 130 P	130	16.0	25.4	41.6	60.1	78.7	113	185	223	254	294	362	475	541	614	733	770
KPH 145 P	145	17.8	28.3	46.4	67.1	87.8	126	206	249	283	328	404	529	603	685	818	859
KPH 155 P	155	19.1	30.2	49.6	71.7	93.9	135	221	266	302	351	432	566	645	732	874	918
KPH 170 P	170	20.9	33.2	54.4	78.6	103	148	242	292	332	385	473	621	707	803	958	1007
KPH 185 P	185	22.8	36.1	59.2	85.6	112	161	263	318	361	419	515	675	770	874	1043	1095
KPH 210 P	210	25.8	41.0	67.2	97.1	127	183	299	361	410	476	585	767	874	992	1184	1244
KPH 230 P	230	28.3	44.9	73.6	106	139	200	328	395	449	521	641	840	957	1087	1297	1362
KPH 240 P	240	29.5	46.8	76.8	111	145	209	342	412	468	544	668	876	998	1134	1353	1421
KPH 255 P	255	31.4	49.7	81.6	118	154	222	363	438	498	578	710	931	1061	1205	1438	1510
KPH 265 P	265	32.6	51.7	84.8	123	160	230	377	455	517	600	738	967	1102	1252	1494	1569

Performance after long term floating with constant voltage charging

Final Voltage: 1.10V/cell

Available amperes at +20° C ± 5° C

Cell Type	C _s Ah	Hours						Minutes					Seconds				
		8	5	3	2	1.5	1	30	20	15	10	5	90	60	30	5	1
KPH 10 P	10	1.21	1.91	3.14	4.62	6.06	8.7	13.4	15.6	17.3	19.7	23.6	29.6	34.4	39.8	48.5	51.9
KPH 12 P	12	1.45	2.30	3.77	5.55	7.27	10.4	16.1	18.8	20.8	23.6	28.4	35.5	41.2	47.8	58.3	62.2
KPH 16 P	16	1.94	3.06	5.03	7.40	9.69	13.9	21.5	25.0	27.7	31.5	37.8	47.4	55.0	63.7	77.7	83.0
KPH 20 P	20	2.42	3.83	6.29	9.25	12.1	17.4	26.8	31.3	34.7	39.4	47.2	59.2	68.7	79.7	97.2	104
KPH 24 P	24	2.90	4.59	7.55	11.1	14.5	20.9	32.2	37.5	41.5	47.4	56.7	71.0	82.4	95.6	117	124
KPH 30 P	30	3.63	5.74	9.43	13.9	18.2	26.1	40.2	46.9	51.9	59.2	70.8	88.8	103	119	146	156
KPH 35 P	35	4.24	6.70	11.0	16.2	21.2	30.4	46.9	54.8	60.6	69.1	82.6	104	120	139	170	182
KPH 40 P	40	4.84	7.65	12.6	18.5	24.2	34.8	53.7	62.6	69.3	78.9	94.4	118	137	159	194	207
KPH 45 P	45	5.45	8.61	14.2	20.8	27.3	39.1	60.3	70.4	78.0	88.7	106	133	155	179	219	233
KPH 50 P	50	6.05	9.57	15.7	23.1	30.3	43.5	67.1	78.2	86.6	98.5	118	148	172	199	243	259
KPH 57 P	57	6.90	10.9	17.9	26.4	34.5	49.6	76.4	89.1	98.7	112	135	169	196	227	277	296
KPH 63 P	63	7.62	12.1	19.8	29.1	38.2	54.8	84.4	98.5	109	124	149	186	216	251	306	327
KPH 69 P	69	8.35	13.2	21.7	31.9	41.8	60.0	92.5	108	119	136	163	204	237	275	335	358
KPH 76 P	76	9.20	14.5	23.9	35.2	46.0	66.1	102	119	132	150	179	225	261	303	369	394
KPH 80 P	80	9.84	15.6	25.6	37.0	48.5	69.6	107	125	138	158	189	237	275	319	389	415
KPH 92 P	92	11.3	17.9	29.4	42.6	55.7	80.0	123	144	159	181	217	272	316	366	447	477
KPH 103 P	103	12.7	20.1	33.0	47.6	62.4	89.6	138	161	178	203	243	305	354	410	500	534
KPH 110 P	110	13.5	21.5	35.2	50.9	66.6	95.7	147	172	191	217	260	326	378	438	534	571
KPH 120 P	120	14.8	23.4	38.4	55.5	72.7	104	161	188	208	236	284	355	412	478	583	622
KPH 130 P	130	16.0	25.4	41.6	60.1	78.7	113	171	198	218	246	288	358	408	464	553	581
KPH 145 P	145	17.8	28.3	46.4	67.1	87.8	126	191	220	243	274	321	400	455	517	617	648
KPH 155 P	155	19.1	30.2	49.6	71.7	93.9	135	204	236	260	293	343	427	487	553	660	693
KPH 170 P	170	20.9	33.2	54.4	78.6	103	148	224	258	285	322	376	468	534	606	724	760
KPH 185 P	185	22.8	36.1	59.2	85.6	112	161	244	281	310	350	410	510	581	660	787	827
KPH 210 P	210	25.8	41.0	67.2	97.1	127	183	277	319	352	397	465	579	660	749	894	939
KPH 230 P	230	28.3	44.9	73.6	106	139	200	303	349	386	435	509	634	722	820	979	1028
KPH 240 P	240	29.5	46.8	76.8	111	145	209	316	365	402	454	531	661	754	856	1022	1073
KPH 255 P	255	31.4	49.7	81.6	118	154	222	336	387	428	482	565	703	801	910	1085	1140
KPH 265 P	265	32.6	51.7	84.8	123	160	230	349	403	444	501	587	730	832	945	1128	1185

Cell Performance H range

Performance fully charged with constant current charging

Available amperes at +20° C ± 5° C

Final Voltage: 1.05V/cell

Cell Type	C _s Ah	Hours						Minutes					Seconds				
		8	5	3	2	1.5	1	30	20	15	10	5	90	60	30	5	1
KPH 10 P	10	1.25	1.97	3.25	4.80	6.29	9.10	16.2	21.2	23.9	28.3	35.5	46.7	54.2	61.6	76.1	81.9
KPH 12 P	12	1.50	2.37	3.90	5.76	7.55	10.9	19.5	25.4	28.7	33.9	42.6	56.0	65.0	73.9	91.3	98.3
KPH 16 P	16	2.00	3.15	5.19	7.68	10.1	14.6	26.0	33.9	38.3	45.2	56.8	74.7	86.7	98.6	122	131
KPH 20 P	20	2.50	3.94	6.49	9.59	12.6	18.2	32.5	42.3	47.8	56.5	71.0	93.4	108	123	152	164
KPH 24 P	24	2.99	4.73	7.79	11.5	15.1	21.8	39.0	50.8	57.4	67.8	85.2	112	130	148	183	197
KPH 30 P	30	3.74	5.91	9.74	14.4	18.9	27.3	48.7	63.5	71.7	84.8	107	140	163	185	228	246
KPH 35 P	35	4.36	6.90	11.4	16.8	22.0	31.9	56.8	74.1	83.7	98.9	124	163	190	216	266	287
KPH 40 P	40	4.98	7.88	13.0	19.2	25.2	36.4	64.9	84.6	95.7	113	142	187	217	246	304	328
KPH 45 P	45	5.60	8.87	14.6	21.6	28.3	41.0	73.0	95.2	108	127	160	210	244	277	342	368
KPH 50 P	50	6.23	9.86	16.2	24.0	31.5	45.5	81.2	106	120	141	178	234	271	308	380	409
KPH 57 P	57	7.10	11.2	18.5	27.3	35.9	51.9	92.5	121	136	161	202	266	309	351	434	467
KPH 63 P	63	7.84	12.4	20.5	30.2	39.6	57.3	102	133	151	178	224	294	341	388	479	516
KPH 69 P	69	8.59	13.6	22.4	33.1	43.4	62.8	112	146	165	195	245	322	374	425	525	565
KPH 76 P	76	9.46	15.0	24.7	36.5	47.8	69.2	123	161	182	215	270	355	412	468	578	622
KPH 80 P	80	9.96	15.8	26.0	38.4	50.3	72.8	130	169	191	226	284	374	434	493	609	655
KPH 92 P	92	11.5	18.1	29.9	44.2	57.9	83.7	149	195	220	260	327	430	499	567	700	753
KPH 103 P	103	12.8	20.3	33.4	49.4	64.8	93.7	167	218	246	291	366	481	558	634	784	843
KPH 110 P	110	13.7	21.7	35.7	52.8	69.2	100	179	233	263	311	391	514	596	678	837	901
KPH 120 P	120	14.9	23.7	39.0	57.6	75.5	109	195	254	287	339	426	560	650	739	913	983
KPH 130 P	130	16.2	25.6	42.2	62.4	81.7	118	210	268	302	353	437	560	637	719	867	905
KPH 145 P	145	18.1	28.6	47.1	69.6	91.1	132	235	299	337	394	488	625	711	802	967	1009
KPH 155 P	155	19.3	30.6	50.3	74.4	97.4	141	251	319	360	421	521	668	760	857	1033	1079
KPH 170 P	170	21.2	33.5	55.2	81.6	107	155	275	350	395	462	572	733	833	940	1133	1183
KPH 185 P	185	23.0	36.5	60.1	88.8	116	168	299	381	430	502	622	797	907	1023	1233	1288
KPH 210 P	210	26.1	41.4	68.2	101	132	191	340	433	488	570	706	905	1029	1161	1400	1462
KPH 230 P	230	28.6	45.3	74.7	110	145	209	372	474	535	625	773	991	1127	1272	1533	1601
KPH 240 P	240	29.9	47.3	77.9	115	151	218	388	494	558	652	807	1034	1176	1327	1600	1671
KPH 255 P	255	31.7	50.3	82.8	122	160	232	413	525	593	693	858	1099	1250	1410	1700	1775
KPH 265 P	265	33.0	52.2	86.0	127	167	241	429	546	616	720	891	1142	1299	1465	1767	1845

Performance after long term floating with constant voltage charging

Available amperes at +20° C ± 5° C

Final Voltage: 1.05V/cell

Cell Type	C _s Ah	Hours						Minutes					Seconds				
		8	5	3	2	1.5	1	30	20	15	10	5	90	60	30	5	1
KPH 10 P	10	1.25	1.97	3.25	4.80	6.29	9.10	16.2	20.2	22.1	25.3	30.3	37.6	43.6	49.6	61.3	65.9
KPH 12 P	12	1.50	2.37	3.90	5.76	7.55	10.9	19.5	24.2	26.5	30.4	36.3	45.1	52.4	59.5	73.5	79.1
KPH 16 P	16	2.00	3.15	5.19	7.68	10.1	14.6	26.0	32.3	35.4	40.5	48.4	60.1	69.8	79.3	98.0	105
KPH 20 P	20	2.50	3.94	6.49	9.59	12.6	18.2	32.5	40.4	44.2	50.6	60.5	75.2	87.3	99.2	123	132
KPH 24 P	24	2.99	4.73	7.79	11.5	15.1	21.8	39.0	48.5	53.1	60.7	72.6	90.2	105	119	147	158
KPH 30 P	30	3.74	5.91	9.74	14.4	18.9	27.3	48.7	60.6	66.4	75.9	90.8	113	131	149	184	198
KPH 35 P	35	4.36	6.90	11.4	16.8	22.0	31.9	56.8	70.7	77.4	88.5	106	132	153	174	214	231
KPH 40 P	40	4.98	7.88	13.0	19.2	25.2	36.4	64.9	80.8	88.5	101	121	150	175	198	245	264
KPH 45 P	45	5.60	8.87	14.6	21.6	28.3	41.0	73.0	90.9	99.5	114	136	169	196	223	276	297
KPH 50 P	50	6.23	9.86	16.2	24.0	31.5	45.5	81.2	101	111	126	151	188	218	248	306	330
KPH 57 P	57	7.10	11.2	18.5	27.3	35.9	51.9	92.5	115	126	144	172	214	249	283	349	376
KPH 63 P	63	7.84	12.4	20.5	30.2	39.6	57.3	102	127	139	159	191	237	275	312	386	415
KPH 69 P	69	8.59	13.6	22.4	33.1	43.4	62.8	112	139	153	175	209	259	301	342	423	455
KPH 76 P	76	9.46	15.0	24.7	36.5	47.8	69.2	123	154	168	192	230	286	332	377	466	501
KPH 80 P	80	9.96	15.8	26.0	38.4	50.3	72.8	130	162	177	202	242	301	349	397	490	527
KPH 92 P	92	11.5	18.1	29.9	44.2	57.9	83.7	149	186	203	233	278	346	401	456	564	606
KPH 103 P	103	12.8	20.3	33.4	49.4	64.8	93.7	167	208	228	261	312	387	449	511	631	679
KPH 110 P	110	13.7	21.7	35.7	52.8	69.2	100	179	222	243	278	333	414	480	545	674	725
KPH 120 P	120	14.9	23.7	39.0	57.6	75.5	109	195	242	265	304	363	451	524	595	735	791
KPH 130 P	130	16.2	25.6	42.2	62.4	81.7	118	210	256	279	316	372	451	513	579	698	728
KPH 145 P	145	18.1	28.6	47.1	69.6	91.1	132	235	285	312	352	415	503	572	645	778	812
KPH 155 P	155	19.3	30.6	50.3	74.4	97.4	141	251	305	333	377	444	538	612	690	832	869
KPH 170 P	170	21.2	33.5	55.2	81.6	107	155	275	334	365	413	487	590	671	757	912	953
KPH 185 P	185	23.0	36.5	60.1	88.8	116	168	299	364	398	450	530	642	730	823	993	1037
KPH 210 P	210	26.1	41.4	68.2	101	132	191	340	413	451	510	602	729	829	935	1127	1177
KPH 230 P	230	28.6	45.3	74.7	110	145	209	372	452	494	559	659	798	908	1024	1234	1289
KPH 240 P	240	29.9	47.3	77.9	115	151	218	388	472	516	583	688	833	947	1068	1288	1345
KPH 255 P	255	31.7	50.3	82.8	122	160	232	413	502	548	620	731	885	1006	1135	1369	1429
KPH 265 P	265	33.0	52.2	86.0	127	167	241	429	521	570	644	759	919	1046	1180	1422	1485

Cell Performance H range

Performance fully charged with constant current charging

Final Voltage: 1.00V/cell

Available amperes at +20° C ± 5° C

Cell Type	C _s Ah	Hours						Minutes					Seconds				
		8	5	3	2	1.5	1	30	20	15	10	5	90	60	30	5	1
KPH 10 P	10	1.26	2.00	3.29	4.88	6.43	9.4	17.2	23.2	27.2	32.3	41.2	53.9	61.4	70.1	88.3	96.8
KPH 12 P	12	1.52	2.40	3.95	5.86	7.72	11.3	20.7	27.8	32.7	38.8	49.4	64.7	73.7	84.2	106	116
KPH 16 P	16	2.02	3.20	5.26	7.81	10.3	15.0	27.6	37.1	43.6	51.7	65.9	86.2	98.3	112	141	155
KPH 20 P	20	2.53	4.00	6.58	9.77	12.9	18.8	34.5	46.4	54.5	64.6	82.3	108	123	140	177	194
KPH 24 P	24	3.03	4.80	7.90	11.7	15.4	22.6	41.4	55.7	65.4	77.6	98.8	129	147	168	212	232
KPH 30 P	30	3.79	6.00	9.87	14.7	19.3	28.2	51.7	69.6	81.7	97.0	123	162	184	210	265	290
KPH 35 P	35	4.42	7.00	11.5	17.1	22.5	32.9	60.4	81.2	95.4	113	144	189	215	246	309	339
KPH 40 P	40	5.05	8.00	13.2	19.5	25.7	37.6	69.0	92.8	109	129	165	216	246	281	353	387
KPH 45 P	45	5.68	9.00	14.8	22.0	29.0	42.3	77.6	104	123	145	185	243	277	316	397	436
KPH 50 P	50	6.31	10.0	16.4	24.4	32.2	47.0	86.2	116	136	162	206	270	307	351	441	484
KPH 57 P	57	7.20	11.4	18.8	27.8	36.7	53.6	98.3	132	155	184	235	307	350	400	503	552
KPH 63 P	63	7.95	12.6	20.7	30.8	40.5	59.3	109	146	172	204	259	340	387	442	556	610
KPH 69 P	69	8.71	13.8	22.7	33.7	44.4	64.9	119	160	188	223	284	372	424	484	609	668
KPH 76 P	76	9.60	15.2	25.0	37.1	48.9	71.5	131	176	207	246	313	410	467	533	671	736
KPH 80 P	80	10.1	16.0	26.4	39.1	51.5	75.2	138	186	218	259	329	431	492	561	706	774
KPH 92 P	92	11.6	18.4	30.4	44.9	59.2	86.5	159	213	251	297	379	496	565	645	812	891
KPH 103 P	103	13.0	20.6	34.0	50.3	66.3	96.9	178	239	281	333	424	555	633	722	909	997
KPH 110 P	110	13.9	22.0	36.3	53.7	70.8	103	190	255	300	356	453	593	676	772	971	1065
KPH 120 P	120	15.2	24.0	39.6	58.6	77.2	113	207	278	327	388	494	647	737	842	1059	1162
KPH 130 P	130	16.4	26.0	42.9	63.5	83.5	122	222	298	344	405	506	653	732	826	1004	1068
KPH 145 P	145	18.3	29.0	47.9	70.8	93.1	136	247	333	384	452	564	728	816	921	1120	1191
KPH 155 P	155	19.6	31.0	51.2	75.7	99.5	146	264	356	410	483	603	778	872	985	1197	1273
KPH 170 P	170	21.5	34.0	56.1	83.0	109	160	290	390	450	530	662	853	957	1080	1313	1397
KPH 185 P	185	23.4	37.0	61.1	90.4	119	174	316	424	490	577	720	929	1041	1175	1429	1520
KPH 210 P	210	26.5	42.0	69.3	103	135	197	358	482	556	655	817	1054	1182	1334	1622	1725
KPH 230 P	230	29.0	46.0	75.9	112	148	216	392	528	609	717	895	1155	1294	1461	1777	1890
KPH 240 P	240	30.3	48.0	79.2	117	154	226	409	551	635	748	934	1205	1351	1525	1854	1972
KPH 255 P	255	32.2	51.0	84.2	125	164	240	435	585	675	795	993	1280	1435	1620	1970	2095
KPH 265 P	265	33.5	53.0	87.5	129	170	249	452	608	701	826	1031	1330	1491	1684	2047	2177

Performance after long term floating with constant voltage charging

Final Voltage: 1.00V/cell

Available amperes at +20° C ± 5° C

Cell Type	C _s Ah	Hours						Minutes					Seconds				
		8	5	3	2	1.5	1	30	20	15	10	5	90	60	30	5	1
KPH 10 P	10	1.26	2.00	3.29	4.88	6.43	9.4	17.2	23.2	26.4	30.2	36.7	45.8	51.9	58.9	74.1	81.3
KPH 12 P	12	1.52	2.40	3.95	5.86	7.72	11.3	20.7	27.8	31.7	36.3	44.1	55.0	62.3	70.7	89.0	97.6
KPH 16 P	16	2.02	3.20	5.26	7.81	10.3	15.0	27.6	37.1	42.3	48.3	58.7	73.3	83.1	94.3	119	130
KPH 20 P	20	2.53	4.00	6.58	9.77	12.9	18.8	34.5	46.4	52.9	60.4	73.4	91.6	104	118	148	163
KPH 24 P	24	3.03	4.80	7.90	11.7	15.4	22.6	41.4	55.7	63.4	72.5	88.1	110	125	141	178	195
KPH 30 P	30	3.79	6.00	9.87	14.7	19.3	28.2	51.7	69.6	79.3	90.7	110	137	156	177	222	244
KPH 35 P	35	4.42	7.00	11.5	17.1	22.5	32.9	60.4	81.2	92.5	106	128	160	182	206	259	285
KPH 40 P	40	5.05	8.00	13.2	19.5	25.7	37.6	69.0	92.8	106	121	147	183	208	236	297	325
KPH 45 P	45	5.68	9.00	14.8	22.0	29.0	42.3	77.6	104	119	136	165	206	234	265	334	366
KPH 50 P	50	6.31	10.0	16.4	24.4	32.2	47.0	86.2	116	132	151	184	229	260	295	371	407
KPH 57 P	57	7.20	11.4	18.8	27.8	36.7	53.6	98.3	132	151	172	209	261	296	336	423	464
KPH 63 P	63	7.95	12.6	20.7	30.8	40.5	59.3	109	146	167	190	231	289	327	371	467	512
KPH 69 P	69	8.71	13.8	22.7	33.7	44.4	64.9	119	160	182	209	253	316	358	407	512	561
KPH 76 P	76	9.60	15.2	25.0	37.1	48.9	71.5	131	176	201	230	279	348	395	448	563	618
KPH 80 P	80	10.1	16.0	26.4	39.1	51.5	75.2	138	186	211	242	294	367	415	471	593	651
KPH 92 P	92	11.6	18.4	30.4	44.9	59.2	86.5	159	213	243	278	338	421	478	542	682	748
KPH 103 P	103	13.0	20.6	34.0	50.3	66.3	96.9	178	239	272	311	378	472	535	607	764	838
KPH 110 P	110	13.9	22.0	36.3	53.7	70.8	103	190	255	291	332	404	504	571	648	816	895
KPH 120 P	120	15.2	24.0	39.6	58.6	77.2	113	207	278	317	363	441	550	623	707	890	976
KPH 130 P	130	16.4	26.0	42.9	63.5	83.5	122	222	298	334	379	451	555	618	694	844	897
KPH 145 P	145	18.3	29.0	47.9	70.8	93.1	136	247	333	372	423	503	619	690	774	941	1001
KPH 155 P	155	19.6	31.0	51.2	75.7	99.5	146	264	356	398	452	538	661	737	827	1006	1070
KPH 170 P	170	21.5	34.0	56.1	83.0	109	160	290	390	437	496	590	725	808	907	1103	1173
KPH 185 P	185	23.4	37.0	61.1	90.4	119	174	316	424	475	539	642	789	880	987	1201	1277
KPH 210 P	210	26.5	42.0	69.3	103	135	197	358	482	539	612	729	896	999	1121	1363	1449
KPH 230 P	230	29.0	46.0	75.9	112	148	216	392	528	591	670	799	981	1094	1227	1493	1587
KPH 240 P	240	30.3	48.0	79.2	117	154	226	409	551	616	700	833	1024	1141	1281	1557	1656
KPH 255 P	255	32.2	51.0	84.2	125	164	240	435	585	655	743	885	1088	1213	1361	1655	1760
KPH 265 P	265	33.5	53.0	87.5	129	170	249	452	608	680	772	920	1131	1260	1414	1720	1829

Cell Performance H range

Performance fully charged cell

Available amperes at +20° C ± 5° C

Final Voltage: 0.85V/cell

Cell Type	C5 Ah	Seconds				
		90	60	30	5	1
KPH 10 P	10	75.8	83.9	95.5	123	134
KPH 12 P	12	90.9	101	115	148	161
KPH 16 P	16	121	134	153	197	215
KPH 20 P	20	152	168	191	246	268
KPH 24 P	24	182	201	229	295	322
KPH 30 P	30	227	252	286	369	403
KPH 35 P	35	265	294	334	431	470
KPH 40 P	40	303	336	382	492	537
KPH 45 P	45	341	378	430	554	604
KPH 50 P	50	379	420	477	615	671
KPH 57 P	57	432	478	544	701	765
KPH 63 P	63	477	529	602	775	845
KPH 69 P	69	523	579	659	849	926
KPH 76 P	76	576	638	726	935	1020
KPH 80 P	80	606	671	764	984	1074
KPH 92 P	92	697	772	879	1132	1235
KPH 103 P	103	780	864	984	1267	1382
KPH 110 P	110	833	923	1051	1353	1476
KPH 120 P	120	909	1007	1146	1477	1610
KPH 130 P	130	921	1009	1127	1389	1517
KPH 145 P	145	1028	1126	1257	1550	1692
KPH 155 P	155	1098	1204	1343	1656	1808
KPH 170 P	170	1205	1320	1473	1817	1983
KPH 185 P	185	1311	1436	1603	1977	2158
KPH 210 P	210	1488	1631	1820	2244	2450
KPH 230 P	230	1630	1786	1993	2458	2683
KPH 240 P	240	1701	1864	2080	2565	2800
KPH 255 P	255	1807	1980	2210	2725	2975
KPH 265 P	265	1878	2058	2297	2832	3092

Final Voltage: 0.65V/cell

Cell Type	C5 Ah	Seconds				
		90	60	30	5	1
KPH 10 P	10	98.1	110	126	161	180
KPH 12 P	12	118	131	151	193	216
KPH 16 P	16	157	175	201	257	288
KPH 20 P	20	196	219	251	322	359
KPH 24 P	24	236	263	301	386	431
KPH 30 P	30	294	329	377	483	539
KPH 35 P	35	343	383	439	563	629
KPH 40 P	40	393	438	502	643	719
KPH 45 P	45	442	493	565	724	809
KPH 50 P	50	491	548	628	804	899
KPH 57 P	57	559	625	715	917	1024
KPH 63 P	63	618	690	791	1013	1132
KPH 69 P	69	677	756	866	1110	1240
KPH 76 P	76	746	833	954	1223	1366
KPH 80 P	80	785	877	1004	1287	1438
KPH 92 P	92	903	1008	1155	1480	1653
KPH 103 P	103	1011	1129	1293	1657	1851
KPH 110 P	110	1079	1205	1381	1770	1977
KPH 120 P	120	1178	1315	1506	1930	2157
KPH 130 P	130	1210	1338	1504	1886	2039
KPH 145 P	145	1349	1493	1677	2104	2275
KPH 155 P	155	1442	1596	1793	2249	2431
KPH 170 P	170	1582	1750	1967	2467	2667
KPH 185 P	185	1721	1904	2140	2684	2902
KPH 210 P	210	1954	2162	2429	3047	3294
KPH 230 P	230	2140	2368	2661	3337	3608
KPH 240 P	240	2233	2471	2776	3482	3765
KPH 255 P	255	2373	2625	2950	3700	4000
KPH 265 P	265	2466	2728	3066	3845	4157

M Range

Cell dimensions

Cell Type	C _s AH	Cell Dimensions in mm			Cell connection bolt size	Container size reference	Volume of electrolyte above plates(cc)	Approximate cell weight (kg)
		Height	Width	Length 1.2V L(1)				
KPM 10 P	10	229	86	46	M8	S1	100	1.3
KPM 13 P	13	229	86	61	M8	S2	130	1.5
KPM 19 P	19	239	134	44	M8	S3	140	1.9
KPM 25 P	25	289	134	59	M10	S4	200	2.4
KPM 32 P	32	289	134	59	M10	S4	200	2.7
KPM 38 P	38	289	134	59	M10	S4	200	3.2
KPM 43 P	43	289	134	59	M10	S4	200	3.8
KPM 54 P	54	289	134	59	M10	S4	200	4.2
KPM 60 P	60	374	134	74	M10	S5	420	5.5
KPM 64 P	64	374	134	74	M10	S5	420	5.6
KPM 75 P	75	374	134	74	M10	S5	420	5.9
KPM 81 P	81	374	134	74	M10	S5	420	6.2
KPM 90 P	90	374	134	74	M10	S5	420	6.4
KPM 96 P	96	374	134	74	M10	S5	420	6.6
KPM 105 P	105	374	134	74	M10	S5	420	7.0
KPM 112 P	112	374	134	74	M10	S5	420	7.3
KPM 120 P	120	374	134	74	M10	S5	420	7.6
KPM 128 P	128	391	134	101	2 X M10	S6	580	9.3
KPM 136 P	136	391	134	101	2 X M10	S6	580	9.6
KPM 145 P	145	391	134	101	2 X M10	S6	580	9.8
KPM 154 P	154	391	134	101	2 X M10	S6	580	10.2
KPM 164 P	164	391	134	101	2 X M10	S6	580	10.5
KPM 178 P	178	417	159	106	2 X M10	S7	740	11.4
KPM 188 P	188	417	159	106	2 X M10	S7	740	11.7
KPM 198 P	198	417	159	106	2 X M10	S7	740	12.2
KPM 212 P	212	417	159	106	2 X M10	S7	740	12.6
KPM 224 P	224	417	159	106	2 X M10	S7	740	13.0
KPM 235 P	235	417	159	106	2 X M10	S7	740	13.2
KPM 248 P	248	417	159	106	2 X M10	S7	740	13.6
KPM 270 P	270	443	163	166	2 X M10	S8	1210	19.2
KPM 285 P	285	443	163	166	2 X M10	S8	1210	19.5
KPM 305 P	305	443	163	166	2 X M10	S8	1210	19.8
KPM 320 P	320	443	163	166	2 X M10	S8	1210	20.0
KPM 330 P	330	443	163	166	2 X M10	S8	1210	20.2
KPM 345 P	345	443	163	166	2 X M10	S8	1210	20.6
KPM 354 P	354	443	163	166	2 X M10	S8	1210	21.0
KPM 370 P	370	443	163	166	2 X M10	S8	1210	21.5
KPM 395 P	395	443	163	166	2 X M10	S8	1210	22.0

Cell Performance M range

Performance fully charged with constant current charging

Final Voltage: 1.14V/cell

Available amperes at +20° C ± 5° C

Cell Type	C ₅ Ah	Hours						Minutes					Seconds			
		8	5	3	2	1.5	1	30	20	15	10	5	60	30	5	1
KPM 10 P	10	1.20	1.89	3.00	4.21	5.16	6.30	8.50	9.89	11.1	12.6	15.2	21.8	24.4	28.5	29.9
KPM 13 P	13	1.56	2.45	3.90	5.47	6.71	8.19	11.1	12.9	14.4	16.4	19.8	28.3	31.7	37.1	38.8
KPM 19 P	19	2.28	3.58	5.70	7.99	9.80	12.0	16.2	18.8	21.1	23.9	28.9	41.4	46.4	54.2	56.7
KPM 25 P	25	3.00	4.72	7.50	10.5	12.9	15.8	21.3	24.7	27.7	31.5	38.0	54.5	61.0	71.3	74.6
KPM 32 P	32	3.84	6.04	9.60	13.5	16.5	20.2	27.2	31.6	35.5	40.3	48.7	69.8	78.1	91.2	95.5
KPM 38 P	38	4.56	7.17	11.4	16.0	19.6	23.9	32.3	37.6	42.1	47.9	57.8	82.8	92.7	108	113
KPM 43 P	43	5.16	8.11	12.9	18.1	22.2	27.1	36.6	42.5	47.6	54.2	65.4	93.7	105	123	128
KPM 54 P	54	6.48	10.2	16.2	22.7	27.9	34.0	45.9	53.4	59.8	68.0	82.1	118	132	154	161
KPM 60 P	60	7.20	11.3	18.0	25.2	31.0	37.8	51.0	59.3	66.5	75.6	91.3	131	146	171	179
KPM 64 P	64	7.68	12.1	19.2	26.9	33.0	40.3	54.4	63.3	70.9	80.6	97.3	140	156	182	191
KPM 75 P	75	9.00	14.1	22.5	31.5	38.7	47.3	63.8	74.2	83.1	94.5	114	164	183	214	224
KPM 81 P	81	9.72	15.3	24.3	34.1	41.8	51.0	68.9	80.1	89.7	102	123	177	198	231	242
KPM 90 P	90	10.8	17.0	27.0	37.9	46.4	56.7	76.5	89.1	100	113	137	196	220	257	269
KPM 96 P	96	11.5	18.1	28.8	40.4	49.5	60.5	81.6	94.9	106	121	146	209	234	274	287
KPM 105 P	105	12.6	19.8	31.5	44.2	54.2	66.2	89.3	104	116	132	160	229	256	299	313
KPM 112 P	112	13.4	21.1	33.6	47.1	57.8	70.6	95.2	111	124	141	170	244	273	319	334
KPM 120 P	120	14.4	22.6	36.0	50.5	61.9	75.6	102	119	133	151	183	262	293	342	358
KPM 128 P	128	15.4	24.1	38.4	53.8	66.0	80.6	109	127	142	161	195	279	312	365	382
KPM 136 P	136	16.3	25.6	40.8	57.2	70.2	85.7	116	135	151	171	207	296	332	388	406
KPM 145 P	145	17.4	27.3	43.5	61.1	74.8	91.4	123	144	161	183	221	316	354	413	433
KPM 154 P	154	18.5	29.0	46.2	64.8	79.5	97.0	131	152	171	194	234	336	376	439	460
KPM 164 P	164	19.7	30.9	49.2	69.0	84.6	103	139	162	182	207	249	358	400	467	490
KPM 178 P	178	21.4	33.5	53.5	74.8	91.5	112	149	175	192	219	262	367	408	470	488
KPM 188 P	188	22.6	35.3	56.6	79.0	96.6	118	158	184	203	231	277	388	431	496	515
KPM 198 P	198	23.8	37.2	59.6	83.2	102	125	166	194	214	244	291	408	453	523	543
KPM 212 P	212	25.4	39.9	63.8	89.0	109	134	178	208	229	261	312	437	485	560	581
KPM 224 P	224	26.9	42.1	67.4	94.1	115	141	188	220	242	276	330	462	513	591	614
KPM 235 P	235	28.2	44.2	70.7	98.7	121	148	197	231	254	289	346	485	538	620	644
KPM 248 P	248	29.8	46.6	74.6	104	127	156	208	243	268	305	365	511	568	655	680
KPM 270 P	270	32.4	50.8	81.2	113	139	170	226	265	292	332	397	557	618	713	740
KPM 285 P	285	34.2	53.6	85.7	120	146	180	239	280	308	351	420	588	653	752	781
KPM 305 P	305	36.6	57.3	91.7	128	157	192	256	299	330	375	449	629	698	805	836
KPM 320 P	320	38.4	60.2	96.3	134	164	202	268	314	346	394	471	660	733	845	877
KPM 330 P	330	39.6	62.0	99.3	139	170	208	277	324	357	406	486	680	756	871	904
KPM 345 P	345	41.4	64.9	104	145	177	217	289	338	373	424	508	711	790	911	945
KPM 354 P	354	42.5	66.6	106	149	182	223	297	347	383	435	521	730	811	935	970
KPM 370 P	370	44.4	69.6	111	155	190	233	310	363	400	455	545	763	847	977	1014
KPM 395 P	395	47.4	74.3	119	166	203	249	331	387	427	486	581	814	905	1043	1082

Cell Performance M range

Performance fully charged with constant current charging

Final Voltage: 1.10V/cell

Available amperes at +20° C ± 5° C

Cell Type	C _s Ah	Hours						Minutes					Seconds			
		8	5	3	2	1.5	1	30	20	15	10	5	60	30	5	1
KPM 10 P	10	1.23	1.94	3.16	4.46	5.65	7.29	9.89	11.7	12.9	14.7	17.8	25.2	28.5	33.7	37.0
KPM 13 P	13	1.60	2.52	4.11	5.80	7.35	9.48	12.9	15.2	16.8	19.1	23.1	32.8	37.1	43.8	48.2
KPM 19 P	19	2.34	3.69	6.00	8.47	10.7	13.9	18.8	22.2	24.5	27.9	33.8	47.9	54.2	64.0	70.4
KPM 25 P	25	3.08	4.85	7.90	11.2	14.1	18.2	24.7	29.3	32.3	36.8	44.5	63.0	71.3	84.3	92.6
KPM 32 P	32	3.94	6.21	10.1	14.3	18.1	23.3	31.6	37.4	41.3	47.0	57.0	80.6	91.2	108	119
KPM 38 P	38	4.67	7.37	12.0	16.9	21.5	27.7	37.6	44.5	49.0	55.9	67.6	95.8	108	128	141
KPM 43 P	43	5.29	8.34	13.6	19.2	24.3	31.3	42.5	50.3	55.5	63.2	76.5	108	123	145	159
KPM 54 P	54	6.64	10.5	17.1	24.1	30.5	39.4	53.4	63.2	69.7	79.4	96.1	136	154	182	200
KPM 60 P	60	7.38	11.6	19.0	26.8	33.9	43.7	59.3	70.2	77.4	88.2	107	151	171	202	222
KPM 64 P	64	7.87	12.4	20.2	28.5	36.2	46.7	63.3	74.9	82.6	94.1	114	161	182	216	237
KPM 75 P	75	9.23	14.6	23.7	33.5	42.4	54.7	74.2	87.8	96.8	110	134	189	214	253	278
KPM 81 P	81	9.96	15.7	25.6	36.1	45.8	59.0	80.1	94.8	104	119	144	204	231	273	300
KPM 90 P	90	11.1	17.5	28.4	40.1	50.9	65.6	89.1	105	116	132	160	227	257	304	333
KPM 96 P	96	11.8	18.6	30.3	42.8	54.2	70.0	94.9	112	124	141	171	242	274	324	356
KPM 105 P	105	12.9	20.4	33.2	46.8	59.3	76.5	104	123	135	154	187	265	299	354	389
KPM 112 P	112	13.8	21.7	35.4	50.0	63.3	81.6	111	131	144	165	199	282	319	377	415
KPM 120 P	120	14.8	23.3	37.9	53.5	67.8	87.5	119	140	155	176	214	302	342	404	444
KPM 128 P	128	15.7	24.8	40.4	57.1	72.3	93.3	127	150	165	188	228	323	365	431	474
KPM 136 P	136	16.7	26.4	43.0	60.7	76.8	99.1	135	159	175	200	242	343	388	458	504
KPM 145 P	145	17.8	28.1	45.8	64.7	81.9	106	144	170	187	213	258	365	413	490	537
KPM 154 P	154	18.9	29.9	48.7	68.7	87.0	112	152	180	199	226	274	388	439	519	570
KPM 164 P	164	20.2	31.8	51.8	73.1	92.7	120	162	192	212	241	292	413	467	553	607
KPM 178 P	178	21.9	34.2	56.1	79.5	100	130	175	205	224	256	306	427	477	562	596
KPM 188 P	188	23.1	36.1	59.2	84.0	106	138	185	216	237	271	323	451	503	594	629
KPM 198 P	198	24.4	38.0	62.4	88.5	112	145	195	228	250	285	341	475	530	626	663
KPM 212 P	212	26.1	40.7	66.8	94.7	120	155	209	244	267	305	365	508	568	670	710
KPM 224 P	224	27.6	43.0	70.6	100	126	164	221	258	282	323	385	537	600	708	750
KPM 235 P	235	28.9	45.1	74.0	105	133	172	231	270	296	338	404	563	629	743	787
KPM 248 P	248	30.5	47.6	78.1	111	140	182	244	285	313	357	427	594	664	784	830
KPM 270 P	270	33.2	51.8	85.1	121	152	198	266	311	340	389	464	647	723	853	904
KPM 285 P	285	35.1	54.7	89.8	127	161	209	281	328	359	410	490	684	763	901	954
KPM 305 P	305	37.5	58.6	96.1	136	172	224	300	351	385	439	525	731	816	964	1021
KPM 320 P	320	39.4	61.4	101	143	180	235	315	368	403	461	550	767	857	1011	1071
KPM 330 P	330	40.6	63.4	104	147	186	242	325	380	416	475	568	791	883	1043	1105
KPM 345 P	345	42.4	66.2	109	154	195	253	340	397	435	497	593	827	924	1090	1155
KPM 354 P	354	43.5	68.0	112	158	200	259	349	407	446	510	609	849	948	1119	1185
KPM 370 P	370	45.5	71.0	117	165	209	271	364	426	466	533	636	887	990	1169	1238
KPM 395 P	395	48.6	75.8	124	176	223	290	389	454	498	569	679	947	1057	1248	1322

Cell Performance **M** range

Performance fully charged with constant current charging

Final Voltage: 1.05V/cell

Available amperes at +20° C ± 5° C

Cell Type	C _s Ah	Hours						Minutes					Seconds			
		8	5	3	2	1.5	1	30	20	15	10	5	60	30	5	1
KPM 10 P	10	1.25	1.98	3.23	4.67	6.00	8.18	11.6	13.5	14.9	17.2	20.9	29.6	33.4	40.4	43.2
KPM 13 P	13	1.63	2.57	4.20	6.07	7.80	10.6	15.1	17.6	19.4	22.3	27.2	38.5	43.4	52.5	56.1
KPM 19 P	19	2.38	3.76	6.14	8.87	11.4	15.5	22.0	25.7	28.3	32.6	39.7	56.2	63.5	76.8	82.0
KPM 25 P	25	3.13	4.95	8.08	11.7	15.0	20.5	29.0	33.8	37.3	43.0	52.2	74.0	83.6	101	108
KPM 32 P	32	4.00	6.34	10.3	14.9	19.1	26.2	37.1	43.2	47.7	55.0	66.8	94.7	107	129	138
KPM 38 P	38	4.75	7.52	12.3	17.7	22.7	31.1	44.0	51.3	56.6	65.3	79.4	112	127	154	164
KPM 43 P	43	5.38	8.51	13.9	20.1	25.7	35.2	49.8	58.1	64.1	73.9	89.8	127	144	174	186
KPM 54 P	54	6.75	10.7	17.4	25.2	32.3	44.2	62.5	72.9	80.5	92.8	113	160	180	218	233
KPM 60 P	60	7.50	11.9	19.4	28.0	35.9	49.1	69.5	81.0	89.4	103	125	178	201	242	259
KPM 64 P	64	8.00	12.7	20.7	29.9	38.3	52.4	74.1	86.4	95.4	110	134	189	214	259	276
KPM 75 P	75	9.38	14.9	24.2	35.0	44.9	61.4	86.9	101	112	129	157	222	251	303	324
KPM 81 P	81	10.1	16.0	26.2	37.8	48.4	66.3	93.8	109	121	139	169	240	271	327	350
KPM 90 P	90	11.3	17.8	29.1	42.0	53.8	73.6	104	122	134	155	188	266	301	364	390
KPM 96 P	96	12.0	19.0	31.0	44.8	57.4	78.5	111	130	143	165	201	284	321	388	414
KPM 105 P	105	13.1	20.8	33.9	49.0	62.8	85.9	122	142	156	180	219	311	351	424	453
KPM 112 P	112	14.0	22.2	36.2	52.3	67.0	91.6	130	151	167	192	234	332	374	452	484
KPM 120 P	120	15.0	23.8	38.8	56.0	71.8	98.2	139	162	179	206	251	355	401	485	518
KPM 128 P	128	16.0	25.3	41.3	59.8	76.5	105	148	173	191	220	267	379	428	517	553
KPM 136 P	136	17.0	26.9	43.9	63.5	81.3	111	157	184	203	234	284	403	455	549	587
KPM 145 P	145	18.1	28.7	46.8	67.7	86.7	119	168	196	216	249	303	429	485	586	628
KPM 154 P	154	19.3	30.5	49.7	71.9	92.1	126	178	208	229	265	322	456	515	622	665
KPM 164 P	164	20.5	32.5	53.0	76.6	98.1	134	190	221	244	282	343	485	548	663	708
KPM 178 P	178	22.3	35.1	57.5	83.1	107	146	205	239	263	299	359	498	561	662	712
KPM 188 P	188	23.5	37.0	60.7	87.8	113	154	216	252	278	315	379	526	592	699	752
KPM 198 P	198	24.8	39.0	64.0	92.5	119	162	228	266	293	332	400	554	624	736	792
KPM 212 P	212	26.5	41.8	68.5	99.0	127	174	244	284	313	356	428	594	668	788	848
KPM 224 P	224	28.0	44.1	72.4	105	134	184	258	301	331	376	452	627	706	833	896
KPM 235 P	235	29.4	46.3	75.9	110	141	193	270	315	347	394	474	658	740	874	940
KPM 248 P	248	31.0	48.9	80.1	116	149	203	285	333	367	416	500	694	781	922	992
KPM 270 P	270	33.8	53.2	87.2	126	162	221	311	362	399	453	545	756	851	1004	1080
KPM 285 P	285	35.6	56.1	92.1	133	171	234	328	382	422	478	575	798	898	1060	1140
KPM 305 P	305	38.1	60.1	98.5	142	183	250	351	409	451	511	615	854	961	1134	1220
KPM 320 P	320	40.0	63.0	103	149	192	262	368	429	473	537	646	896	1008	1190	1280
KPM 330 P	330	41.3	65.0	107	154	198	271	380	443	488	553	666	924	1040	1227	1320
KPM 345 P	345	43.1	68.0	111	161	207	283	397	463	510	579	696	966	1087	1283	1380
KPM 354 P	354	44.3	69.7	114	165	212	290	407	475	523	594	714	991	1115	1316	1416
KPM 370 P	370	46.3	72.9	120	173	222	303	426	496	547	620	747	1036	1166	1376	1480
KPM 395 P	395	49.4	77.8	128	184	237	324	454	530	584	662	797	1106	1244	1469	1580

Cell Performance **M** range

Performance fully charged with constant current charging

Final Voltage: 1.00/cell

Available amperes at +20° C ± 5° C

Cell Type	C _s Ah	Hours						Minutes					Seconds			
		8	5	3	2	1.5	1	30	20	15	10	5	60	30	5	1
KPM 10 P	10	1.26	2.00	3.25	4.79	6.20	8.60	13.0	15.2	16.9	19.4	23.7	33.4	38.9	46.2	49.3
KPM 13 P	13	1.64	2.60	4.23	6.23	8.06	11.2	16.9	19.8	22.0	25.2	30.8	43.4	50.6	60.1	64.1
KPM 19 P	19	2.39	3.80	6.18	9.10	11.8	16.3	24.7	28.9	32.1	36.8	45.0	63.5	73.9	87.8	93.7
KPM 25 P	25	3.15	5.00	8.13	12.0	15.5	21.5	32.5	38.0	42.3	48.5	59.3	83.5	97.3	116	123
KPM 32 P	32	4.03	6.40	10.4	15.3	19.8	27.5	41.6	48.7	54.1	62.0	75.8	107	124	148	158
KPM 38 P	41	4.79	7.60	12.4	18.2	23.6	32.7	49.4	57.8	64.2	73.6	90.1	127	148	176	187
KPM 43 P	43	5.42	8.60	14.0	20.6	26.7	37.0	55.9	65.4	72.7	83.3	102	144	167	199	212
KPM 54 P	54	6.80	10.8	17.6	25.9	33.5	46.4	70.2	82.1	91.3	105	128	180	210	250	266
KPM 60 P	60	7.56	12.0	19.5	28.7	37.2	51.6	78.0	91.3	101	116	142	200	233	277	296
KPM 64 P	64	8.06	12.8	20.8	30.7	39.7	55.0	83.2	97.3	108	124	152	214	249	296	316
KPM 75 P	75	9.45	15.0	24.4	35.9	46.5	64.5	97.5	114	127	145	178	251	292	347	370
KPM 81 P	81	10.2	16.2	26.3	38.8	50.2	69.7	105	123	137	157	192	271	315	374	399
KPM 90 P	90	11.3	18.0	29.3	43.1	55.8	77.4	117	137	152	174	213	301	350	416	444
KPM 96 P	96	12.1	19.2	31.2	46.0	59.5	82.6	125	146	162	186	228	321	373	444	473
KPM 105 P	105	13.2	21.0	34.1	50.3	65.1	90.3	137	160	177	203	249	351	408	485	518
KPM 112 P	112	14.1	22.4	36.4	53.6	69.4	96.3	146	170	189	217	265	374	436	518	552
KPM 120 P	120	15.1	24.0	39.0	57.5	74.4	103	156	183	203	233	284	401	467	555	592
KPM 128 P	128	16.1	25.6	41.6	61.3	79.4	110	166	195	216	248	303	428	498	592	631
KPM 136 P	136	17.1	27.2	44.2	65.1	84.3	117	177	207	230	264	322	454	529	629	670
KPM 145 P	145	18.3	29.0	47.1	69.5	89.9	125	189	221	245	281	344	484	564	670	715
KPM 154 P	154	19.4	30.8	50.1	73.8	95.5	132	200	234	260	298	365	514	599	712	759
KPM 164 P	164	20.7	32.8	53.3	78.6	102	141	213	249	277	318	389	548	638	758	809
KPM 178 P	178	22.4	35.6	58.1	85.1	110	153	230	269	297	341	411	573	643	768	812
KPM 188 P	188	23.7	37.6	61.4	89.9	117	161	243	284	314	360	434	605	680	811	857
KPM 198 P	198	24.9	39.6	64.7	94.6	123	170	256	299	331	379	457	637	716	854	903
KPM 212 P	212	26.7	42.4	69.2	101	131	182	274	320	354	406	490	682	766	915	967
KPM 224 P	224	28.2	44.8	73.2	107	139	192	289	338	374	429	517	721	810	967	1021
KPM 235 P	235	29.6	47.0	76.8	112	146	201	304	355	393	450	543	756	850	1014	1072
KPM 248 P	248	31.2	49.6	81.0	119	154	213	320	374	414	474	573	798	897	1070	1131
KPM 270 P	270	34.0	54.0	88.2	129	167	231	349	408	451	517	624	869	976	1165	1231
KPM 285 P	285	35.9	57.0	93.1	136	177	244	368	430	476	545	658	917	1030	1230	1300
KPM 305 P	305	38.4	61.0	100	146	189	261	394	460	510	583	705	981	1103	1316	1391
KPM 320 P	320	40.3	64.0	105	153	198	274	413	483	535	612	739	1029	1157	1381	1459
KPM 330 P	330	41.6	66.0	108	158	205	283	426	498	551	631	762	1062	1193	1424	1505
KPM 345 P	345	43.5	69.0	113	165	214	296	446	521	576	660	797	1110	1247	1489	1573
KPM 354 P	354	44.6	70.8	116	169	219	303	457	534	591	677	818	1139	1280	1528	1614
KPM 370 P	370	46.6	74.0	121	177	229	317	478	558	618	708	855	1190	1338	1597	1687
KPM 395 P	395	49.8	79.0	129	189	245	339	510	596	660	756	912	1271	1428	1704	1801

Cell Performance **M** range

Performance after long term floating with constant voltage charging

Final Voltage: 1.14V/cell

Available amperes at +20° C ± 5° C

Cell Type	C _s Ah	Hours						Minutes					Seconds			
		8	5	3	2	1.5	1	30	20	15	10	5	60	30	5	1
KPM 10 P	10	1.20	1.89	2.90	3.79	4.44	5.10	6.38	7.14	7.8	8.69	10.2	14.6	16.3	19.1	20.0
KPM 13 P	13	1.56	2.45	3.76	4.93	5.77	6.63	8.29	9.28	10.2	11.3	13.3	19.0	21.3	24.8	26.0
KPM 19 P	19	2.28	3.58	5.50	7.21	8.43	9.70	12.1	13.6	14.8	16.5	19.4	27.8	31.1	36.3	38.0
KPM 25 P	25	3.00	4.72	7.24	9.48	11.1	12.8	15.9	17.9	19.5	21.7	25.6	36.5	40.9	47.7	50.0
KPM 32 P	32	3.84	6.04	9.26	12.1	14.2	16.3	20.4	22.8	25.0	27.8	32.8	46.7	52.3	61.1	64.0
KPM 38 P	38	4.56	7.17	11.0	14.4	16.9	19.4	24.2	27.1	29.7	33.0	38.9	55.5	62.1	72.6	76.0
KPM 43 P	43	5.16	8.11	12.4	16.3	19.1	21.9	27.4	30.7	33.6	37.4	44.0	62.8	70.3	82.1	86.0
KPM 54 P	54	6.48	10.2	15.6	20.5	24.0	27.6	34.4	38.6	42.2	46.9	55.3	78.9	88.3	103	108
KPM 60 P	60	7.20	11.3	17.4	22.8	26.6	30.6	38.3	42.8	46.9	52.2	61.4	87.6	98.1	115	120
KPM 64 P	64	7.68	12.1	18.5	24.3	28.4	32.7	40.8	45.7	50.0	55.6	65.5	93.5	105	122	128
KPM 75 P	75	9.00	14.1	21.7	28.4	33.3	38.3	47.8	53.5	58.6	65.2	76.8	110	123	143	150
KPM 81 P	81	9.72	15.3	23.4	30.7	35.9	41.3	51.6	57.8	63.3	70.4	82.9	118	132	155	162
KPM 90 P	90	10.8	17.0	26.1	34.1	39.9	45.9	57.4	64.3	70.3	78.2	92.1	132	147	172	180
KPM 96 P	96	11.5	18.1	27.8	36.4	42.6	49.0	61.2	68.5	75.0	83.5	98.3	140	157	183	192
KPM 105 P	105	12.6	19.8	30.4	39.8	46.6	53.6	66.9	75.0	82.0	91.3	108	153	172	201	210
KPM 112 P	112	13.4	21.1	32.4	42.5	49.7	57.2	71.4	80.0	87.5	97.4	115	164	183	214	224
KPM 120 P	120	14.4	22.6	34.7	45.5	53.2	61.2	76.5	85.7	93.7	104	123	175	196	229	240
KPM 128 P	128	15.4	24.1	37.1	48.6	56.8	65.3	81.6	91.4	100	111	131	187	209	244	256
KPM 136 P	136	16.3	25.6	39.4	51.6	60.3	69.4	86.7	97.1	106	118	139	199	222	260	272
KPM 145 P	145	17.4	27.3	42.0	55.1	64.3	74.0	92.4	104	113	126	148	212	237	277	290
KPM 154 P	154	18.5	29.0	44.6	58.4	68.3	78.6	98.2	110	120	134	158	225	252	294	308
KPM 164 P	164	19.7	30.9	47.5	62.2	72.8	83.7	105	117	128	143	168	240	268	313	328
KPM 178 P	178	21.4	33.5	51.7	67.4	78.7	90.8	112	126	136	151	176	246	273	315	327
KPM 188 P	188	22.6	35.3	54.6	71.2	83.1	95.9	118	133	143	160	186	260	288	333	345
KPM 198 P	198	23.8	37.2	57.5	75.0	87.5	101	125	140	151	168	196	274	304	350	364
KPM 212 P	212	25.4	39.9	61.5	80.3	93.7	108	133	150	162	180	210	293	325	375	389
KPM 224 P	224	26.9	42.1	65.0	84.9	99.0	114	141	159	171	190	221	310	344	396	411
KPM 235 P	235	28.2	44.2	68.2	89.0	104	120	148	166	179	199	233	325	361	416	431
KPM 248 P	248	29.8	46.6	72.0	93.9	110	127	156	176	189	210	246	343	381	439	455
KPM 270 P	270	32.4	50.8	78.4	102	119	138	170	191	206	229	268	373	414	478	496
KPM 285 P	285	34.2	53.6	82.7	108	126	145	179	202	217	242	282	394	437	504	523
KPM 305 P	305	36.6	57.3	88.5	116	135	156	192	216	232	259	302	421	468	540	560
KPM 320 P	320	38.4	60.2	92.9	121	141	163	201	227	244	272	317	442	491	566	588
KPM 330 P	330	39.6	62.0	95.8	125	146	168	208	234	252	280	327	456	506	584	606
KPM 345 P	345	41.4	64.9	100	131	153	176	217	244	263	293	349	477	529	610	633
KPM 354 P	354	42.5	66.5	103	134	156	181	223	251	270	300	351	489	543	626	650
KPM 370 P	370	44.4	69.6	107	140	164	189	233	262	282	314	367	511	568	655	679
KPM 395 P	395	47.4	74.3	115	150	175	202	248	280	301	335	391	546	606	699	725

Cell Performance **M** range

Performance after long term floating with constant voltage charging

Final Voltage: 1.10V/cell

Available amperes at +20° C ± 5° C

Cell Type	C ₅ Ah	Hours						Minutes					Seconds			
		8	5	3	2	1.5	1	30	20	15	10	5	60	30	5	1
KPM 10 P	10	1.23	1.94	3.16	4.28	5.20	6.34	7.91	9.0	9.7	10.8	12.8	17.8	20.1	23.8	26.2
KPM 13 P	13	1.60	2.52	4.11	5.57	6.76	8.24	10.3	11.7	12.7	14.1	16.6	23.2	26.2	31.0	34.0
KPM 19 P	19	2.34	3.69	6.00	8.14	9.88	12.0	15.0	17.2	18.5	20.6	24.2	33.9	38.3	45.3	49.8
KPM 25 P	25	3.08	4.85	7.90	10.7	13.0	15.9	19.8	22.6	24.3	27.1	31.9	44.5	50.4	59.6	65.5
KPM 32 P	32	3.94	6.21	10.1	13.7	16.6	20.3	25.3	28.9	31.2	34.7	40.8	57.0	64.5	76.2	83.8
KPM 38 P	38	4.67	7.37	12.0	16.3	19.8	24.1	30.1	34.3	37.0	41.2	48.5	67.7	76.6	90.5	99.5
KPM 43 P	43	5.29	8.34	13.6	18.4	22.4	27.3	34.0	38.8	41.9	46.6	54.9	76.6	86.6	103	113
KPM 54 P	54	6.64	10.5	17.1	23.1	28.1	34.2	42.7	48.8	52.6	58.6	68.9	96.2	109	129	141
KPM 60 P	60	7.38	11.6	19.0	25.7	31.2	38.0	47.5	54.2	58.4	65.1	76.6	107	121	143	157
KPM 64 P	64	7.87	12.4	20.2	27.4	33.3	40.6	50.6	57.8	62.3	69.4	81.7	114	129	153	168
KPM 75 P	75	9.23	14.6	23.7	32.1	39.0	47.6	59.3	67.7	73.0	81.4	95.7	134	151	179	196
KPM 81 P	81	9.96	15.7	25.6	34.7	42.1	51.4	64.1	73.2	78.9	87.9	103	144	163	193	212
KPM 90 P	90	11.1	17.5	28.4	38.5	46.8	57.1	71.3	81.3	87.7	97.6	115	160	181	215	236
KPM 96 P	96	11.8	18.6	30.3	41.1	49.9	60.9	76.0	86.7	93.5	104	123	171	193	229	251
KPM 105 P	105	12.9	20.4	33.2	45.0	54.6	66.9	83.1	94.8	102	114	134	187	212	250	275
KPM 112 P	112	13.8	21.7	35.4	48.0	58.2	71.0	88.6	101	109	122	143	200	226	267	293
KPM 120 P	120	14.8	23.3	37.9	51.4	62.4	76.1	94.9	108	117	130	153	214	242	286	314
KPM 128 P	128	15.7	24.8	40.4	54.8	66.5	81.2	101	116	125	139	163	228	258	305	335
KPM 136 P	136	16.7	26.4	43.0	58.2	70.7	86.3	108	123	133	148	174	242	274	324	356
KPM 145 P	145	17.8	28.1	45.8	62.1	75.4	92.0	115	131	141	157	185	258	292	347	380
KPM 154 P	154	18.9	29.9	48.7	65.9	80.0	97.7	122	139	150	167	197	274	310	367	403
KPM 164 P	164	20.2	31.8	51.8	70.2	85.2	104	130	148	160	178	209	292	331	391	430
KPM 178 P	178	21.9	34.2	56.1	76.3	92.4	114	140	158	169	189	220	302	337	398	421
KPM 188 P	188	23.1	36.1	59.2	80.6	97.5	120	148	167	179	200	232	319	356	420	445
KPM 198 P	198	24.4	38.0	62.4	84.9	103	126	156	176	189	210	244	336	375	442	469
KPM 212 P	212	26.1	40.7	66.8	90.9	110	135	167	188	202	225	261	359	401	474	508
KPM 224 P	224	27.6	43.0	70.6	96.1	116	143	177	199	213	238	276	380	424	500	530
KPM 235 P	235	28.9	45.1	74.0	101	122	150	185	209	224	250	290	398	445	525	556
KPM 248 P	248	30.5	47.6	78.1	106	129	158	195	220	236	264	306	420	469	554	587
KPM 270 P	270	33.2	51.8	85.1	116	140	172	213	240	257	287	333	458	511	603	639
KPM 285 P	285	35.1	54.7	89.8	122	148	182	225	253	271	303	352	484	539	637	674
KPM 305 P	305	37.5	58.6	96.1	131	158	195	240	271	290	324	376	517	577	681	722
KPM 320 P	320	39.4	61.4	101	137	166	204	252	284	305	340	395	542	606	715	757
KPM 330 P	330	40.6	63.4	104	142	171	210	260	293	314	351	407	600	625	737	781
KPM 345 P	345	42.4	66.2	109	148	179	220	272	306	328	367	426	585	653	771	816
KPM 354 P	354	43.5	68.0	112	152	184	226	279	314	337	376	437	599	670	791	838
KPM 370 P	370	45.5	71.0	117	159	192	236	292	329	352	393	456	627	700	827	876
KPM 395 P	395	48.6	75.8	124	169	205	252	311	351	376	420	487	669	748	883	935

Cell Performance **M** range

Performance after long term floating with constant voltage charging

Final Voltage: 1.05V/cell

Available amperes at +20° C ± 5° C

Cell Type	C ₅ Ah	Hours						Minutes					Seconds			
		8	5	3	2	1.5	1	30	20	15	10	5	60	30	5	1
KPM 10 P	10	1.25	1.98	3.23	4.67	5.82	7.57	9.8	11.1	12.0	13.5	15.9	22.2	25.1	30.3	32.4
KPM 13 P	13	1.63	2.57	4.20	6.07	7.56	9.84	12.8	14.4	15.6	17.6	20.7	28.9	32.6	39.4	42.1
KPM 19 P	19	2.38	3.76	6.14	8.87	11.1	14.4	18.7	21.0	22.8	25.7	30.2	42.2	47.6	57.6	61.5
KPM 25 P	25	3.13	4.95	8.08	11.7	14.5	18.4	24.6	27.7	30.0	33.8	39.8	55.5	62.7	75.8	80.9
KPM 32 P	32	4.00	6.34	10.3	14.9	18.6	24.2	31.5	35.4	38.4	43.3	50.9	71.0	80.2	97.0	104
KPM 38 P	38	4.75	7.52	12.3	17.7	22.1	28.7	37.4	42.1	45.6	51.4	60.5	84.4	95.2	115	123
KPM 43 P	43	5.38	8.51	13.9	20.1	25.0	32.5	42.3	47.6	51.6	58.1	68.4	95.5	108	130	139
KPM 54 P	54	6.75	10.7	17.4	25.2	31.4	40.9	53.2	59.8	64.8	73.0	86.0	120	135	164	175
KPM 60 P	60	7.50	11.9	19.4	28.0	34.9	45.4	59.1	66.4	72.0	81.1	95.5	133	150	182	194
KPM 64 P	64	8.00	12.7	20.7	29.9	37.2	48.4	63.0	70.8	76.8	86.5	102	142	160	194	207
KPM 75 P	75	9.38	14.9	24.2	35.0	43.6	56.7	73.8	83.0	90.0	101	119	167	188	227	243
KPM 81 P	81	10.1	16.0	26.2	37.8	47.1	61.3	79.7	89.7	97.2	110	129	180	203	245	262
KPM 90 P	90	11.2	17.8	29.1	42.0	52.4	68.1	88.6	99.6	108	122	143	200	226	273	292
KPM 96 P	96	12.0	19.0	31.0	44.8	55.9	72.6	94.5	106	115	130	153	213	241	291	311
KPM 105 P	105	13.1	20.8	33.9	49.0	61.1	79.4	103	116	126	142	167	233	263	318	340
KPM 112 P	112	14.0	22.2	36.2	52.3	65.2	84.7	110	124	134	151	178	249	281	339	363
KPM 120 P	120	15.0	23.8	38.8	56.0	69.8	90.8	118	133	144	162	191	266	301	364	389
KPM 128 P	128	16.0	25.3	41.3	59.8	74.5	96.8	126	142	154	173	204	284	321	388	414
KPM 136 P	136	17.0	26.9	43.9	63.5	79.1	103	134	151	163	184	217	302	341	412	440
KPM 145 P	145	18.1	28.7	46.8	67.7	84.4	110	143	161	174	196	231	322	363	439	471
KPM 154 P	154	19.3	30.5	49.7	71.9	89.6	117	152	171	185	208	245	342	386	467	499
KPM 164 P	164	20.5	32.5	53.0	76.6	95.4	124	161	182	197	222	261	364	411	497	531
KPM 178 P	178	22.3	35.1	57.5	83.1	104	135	174	196	212	235	274	374	421	496	534
KPM 188 P	188	23.5	37.0	60.7	87.8	110	143	184	207	224	248	289	395	444	524	564
KPM 198 P	198	24.8	39.0	63.9	92.5	116	150	194	218	236	261	305	416	468	552	594
KPM 212 P	212	26.5	41.8	68.5	99.0	124	161	207	233	252	279	326	445	501	591	636
KPM 224 P	224	28.0	44.1	72.4	105	131	170	219	246	267	296	344	470	529	625	672
KPM 235 P	235	29.4	46.3	75.9	110	137	178	230	259	280	310	361	494	555	655	705
KPM 248 P	248	31.0	48.9	80.1	116	145	188	242	273	295	327	381	521	586	692	744
KPM 270 P	270	33.8	53.2	87.2	126	158	205	264	297	321	356	415	567	638	753	810
KPM 285 P	285	35.6	56.1	92.1	133	166	216	279	314	340	376	438	599	673	795	855
KPM 305 P	305	38.1	60.1	98.5	142	178	231	298	336	363	403	469	641	721	851	915
KPM 320 P	320	40.0	63.0	103	149	187	243	313	352	381	422	492	672	756	892	960
KPM 330 P	330	41.3	65.0	107	154	193	250	323	363	393	436	507	693	780	920	990
KPM 345 P	345	43.1	68.0	111	161	201	262	337	380	411	455	531	725	815	962	1035
KPM 354 P	354	44.3	69.7	114	165	207	269	346	389	421	467	544	743	836	987	1062
KPM 370 P	370	46.3	72.9	120	173	216	281	362	407	440	488	569	777	874	1032	1110
KPM 395 P	395	49.4	77.8	128	184	231	300	386	435	470	521	607	830	933	1106	1185

Cell Performance **M** range

Performance after long term floating with constant voltage charging

Final Voltage: 1.00/cell

Available amperes at +20° C ± 5° C

Cell Type	C ₅ Ah	Hours						Minutes					Seconds			
		8	5	3	2	1.5	1	30	20	15	10	5	60	30	5	1
KPM 10 P	10	1.26	2.00	3.25	4.79	6.20	8.21	11.6	13.1	14.3	16.0	19.1	26.7	31.1	37.0	39.4
KPM 13 P	13	1.64	2.60	4.23	6.23	8.06	10.7	15.0	17.0	18.6	20.8	24.9	34.7	40.5	48.1	51.3
KPM 19 P	19	2.39	3.80	6.18	9.10	11.8	15.6	22.0	24.9	27.1	30.4	36.3	50.8	59.1	70.3	74.9
KPM 25 P	25	3.15	5.00	8.13	12.0	15.5	20.5	28.9	32.8	35.7	40.0	47.8	66.8	77.8	92.5	98.6
KPM 32 P	32	4.03	6.40	10.4	15.3	19.8	26.3	37.0	42.0	45.7	51.2	61.2	85.5	99.6	118	126
KPM 38 P	38	4.79	7.60	12.3	18.2	23.6	31.2	44.0	49.8	54.3	60.8	72.7	102	118	141	150
KPM 43 P	43	5.42	8.60	14.0	20.6	26.7	35.3	49.8	56.4	61.4	68.8	82.2	115	134	159	170
KPM 54 P	54	6.80	10.8	17.6	25.9	33.5	44.3	62.5	70.8	77.1	86.3	103	144	168	200	213
KPM 60 P	60	7.56	12.0	19.5	28.7	37.2	49.3	69.4	78.7	85.7	95.9	115	160	187	222	237
KPM 64 P	64	8.06	12.8	20.8	30.7	39.7	52.6	74.0	83.9	91.4	102	122	171	199	237	252
KPM 75 P	75	9.45	15.0	24.4	35.9	46.5	61.6	86.8	98.3	107	120	143	200	233	277	296
KPM 81 P	81	10.2	16.2	26.3	38.8	50.2	66.5	93.7	106	116	130	155	216	252	300	320
KPM 90 P	90	11.3	18.0	29.3	43.1	55.8	73.9	104	118	129	144	172	241	280	333	355
KPM 96 P	96	12.1	19.2	31.2	46.0	59.5	78.8	111	126	137	154	184	257	299	355	379
KPM 105 P	105	13.2	21.0	34.1	50.3	65.1	86.2	122	138	150	168	201	281	327	388	414
KPM 112 P	112	14.1	22.4	36.4	53.6	69.4	92.0	130	147	160	179	214	299	349	414	442
KPM 120 P	120	15.1	24.0	39.0	57.5	74.4	98.6	139	157	171	192	230	321	373	444	473
KPM 128 P	128	16.1	25.6	41.6	61.3	79.4	105	148	168	183	205	245	342	398	473	505
KPM 136 P	136	17.1	27.2	44.2	65.1	84.3	112	157	178	194	217	260	363	423	503	536
KPM 145 P	145	18.3	29.0	47.1	69.5	89.9	119	168	190	207	232	277	387	451	536	572
KPM 154 P	154	19.4	30.8	50.0	73.8	95.5	126	178	202	220	246	295	412	479	570	607
KPM 164 P	164	20.7	32.8	53.3	78.6	102	135	190	215	234	262	314	439	510	607	647
KPM 178 P	178	22.4	35.6	58.1	85.1	110	146	205	232	251	281	332	458	515	615	649
KPM 188 P	188	23.7	37.6	61.4	89.9	117	154	216	245	265	297	351	484	544	649	686
KPM 198 P	198	24.9	39.6	64.7	94.6	123	162	228	258	280	313	369	510	573	684	722
KPM 212 P	212	26.7	42.4	69.2	101	131	174	244	276	299	335	395	546	613	732	773
KPM 224 P	224	28.2	44.8	73.2	107	139	183	258	291	316	354	418	577	648	773	817
KPM 235 P	235	29.6	47.0	76.8	112	146	192	270	306	332	371	438	605	680	811	857
KPM 248 P	248	31.2	49.6	81.0	119	154	203	285	323	350	391	462	638	717	856	905
KPM 270 P	270	34.0	54.0	88.2	129	167	221	311	351	381	426	503	695	781	932	985
KPM 285 P	285	35.9	57.0	93.1	136	177	233	328	371	402	450	531	734	824	984	1040
KPM 305 P	305	38.4	61.0	99.6	146	189	250	351	397	431	481	569	785	882	1053	1113
KPM 320 P	320	40.3	64.0	105	153	198	262	368	416	452	505	597	824	925	1105	1167
KPM 330 P	330	41.6	66.0	108	158	205	270	380	429	466	521	615	849	954	1139	1204
KPM 345 P	345	43.5	69.0	113	165	214	282	397	449	487	544	643	888	998	1191	1259
KPM 354 P	354	44.6	70.8	116	169	219	290	407	461	500	559	660	911	1024	1222	1291
KPM 370 P	370	46.6	74.0	121	177	229	303	426	481	522	584	690	952	1070	1277	1350
KPM 395 P	395	49.8	79.0	129	189	245	323	454	514	558	623	736	1017	1142	1364	1441

L Range

Cell dimensions

Cell Type	C ₅ AH	Cell Dimensions in mm			Cell connection bolt size	Container size reference	Volume of electrolyte above plates(cc)	Approximate cell weight (kgs)
		Height	Width	Length 1.2V L(1)				
KPL 11 P	11	229	86	46	M8	S1	100	1.4
KPL 17 P	17	229	86	46	M8	S1	100	1.6
KPL 23 P	23	229	86	61	M8	S2	130	1.9
KPL 27 P	27	289	134	59	M10	S4	200	3.2
KPL 36 P	36	289	134	59	M10	S4	200	3.8
KPL 41 P	41	289	134	59	M10	S4	200	4.2
KPL 55 P	55	289	134	59	M10	S4	200	4.5
KPL 60 P	60	374	134	74	M10	S5	420	5.3
KPL 69 P	69	374	134	74	M10	S5	420	5.8
KPL 80 P	80	374	134	74	M10	S5	420	6.1
KPL 92 P	92	374	134	74	M10	S5	420	6.3
KPL 100 P	100	374	134	74	M10	S5	420	6.4
KPL 115 P	115	374	134	74	M10	S5	420	6.6
KPL 120 P	120	374	134	74	M10	S5	420	6.8
KPL 135 P	135	391	134	101	2 X M10	S6	580	9.5
KPL 150 P	150	391	134	101	2 X M10	S6	580	10.0
KPL 160 P	160	391	134	101	2 X M10	S6	580	10.4
KPL 170 P	170	391	134	101	2 X M10	S6	580	10.7
KPL 180 P	180	391	134	101	2 X M10	S6	580	11.0
KPL 190 P	190	417	159	106	2 X M10	S7	740	12.5
KPL 210 P	210	417	159	106	2 X M10	S7	740	12.8
KPL 220 P	220	417	159	106	2 X M10	S7	740	13.0
KPL 235 P	235	417	159	106	2 X M10	S7	740	13.5
KPL 255 P	255	417	159	106	2 X M10	S7	740	13.8
KPL 270 P	270	417	159	106	2 X M10	S7	740	14.0
KPL 285 P	285	417	159	106	2 X M10	S7	740	14.3
KPL 300 P	300	443	163	166	2 X M10	S8	1210	19.0
KPL 335 P	335	443	163	166	2 X M10	S8	1210	19.6
KPL 355 P	355	443	163	166	2 X M10	S8	1210	21.3
KPL 370 P	370	443	163	166	2 X M10	S8	1210	21.5
KPL 390P	390	443	163	166	2 X M10	S8	1210	22.0
KPL 410P	410	443	163	166	2 X M10	S8	1210	22.4
KPL 425P	425	443	163	166	2 X M10	S8	1210	22.6
KPL 445P	445	443	163	166	2 X M10	S8	1210	22.9
KPL 460P	460	443	163	166	2 X M10	S8	1210	23.2
KPL 480P	480	443	163	166	2 X M10	S8	1210	23.5

Cell Performance **L** range
 Performance fully charged with constant current charging

Final Voltage: 1.14V/cell

Available amperes at +20° C ± 5° C

Cell Type	C _s Ah	Hours							Minutes					Seconds			
		10	8	5	3	2	1.5	1	30	20	15	10	5	60	30	5	1
KPL 11 P	11	1.08	1.33	2.07	3.27	4.22	4.84	5.61	7.04	7.92	8.56	9.45	11.0	14.4	15.5	16.7	18.7
KPL 17 P	17	1.66	2.06	3.20	5.05	6.52	7.48	8.67	10.9	12.2	13.2	14.6	17.0	22.3	23.9	25.8	29.0
KPL 23 P	23	2.25	2.78	4.32	6.83	8.82	10.1	11.7	14.7	16.6	17.9	19.8	23.0	30.2	32.4	35.0	39.2
KPL 27 P	27	2.64	3.26	5.08	8.02	10.4	11.9	13.8	17.3	19.4	21.0	23.2	27.0	35.4	38.0	41.0	46.0
KPL 36 P	36	3.52	4.35	6.77	10.7	13.8	15.8	18.4	23.0	25.9	28.0	30.9	36.0	47.2	50.7	54.7	61.3
KPL 41 P	41	4.01	4.96	7.71	12.2	15.7	18.0	20.9	26.2	29.5	31.9	35.2	41.0	53.8	57.7	62.3	69.9
KPL 55 P	55	5.38	6.65	10.4	16.3	21.1	24.2	28.1	35.2	39.6	42.8	47.3	55.0	72.1	77.4	83.6	93.7
KPL 60 P	60	5.87	7.25	11.3	17.8	23.0	26.4	30.6	38.4	43.2	46.7	51.6	60.0	78.7	84.4	91.2	102
KPL 69 P	69	6.75	8.34	13.0	20.5	26.5	30.4	35.2	44.2	49.7	53.7	59.3	69.0	90.4	97.1	105	118
KPL 80 P	80	7.82	9.67	15.1	23.8	30.7	35.2	40.8	51.2	57.6	62.2	68.7	80.0	105	113	122	136
KPL 92 P	92	9.00	11.1	17.4	27.3	35.3	40.5	47.0	58.9	66.2	71.6	79.1	92.0	121	129	140	157
KPL 100 P	100	9.78	12.1	18.9	29.7	38.4	44.0	51.0	64.0	72.0	77.8	85.9	100	131	141	152	170
KPL 115 P	115	11.2	13.9	21.7	34.2	44.1	50.6	58.7	73.6	82.8	89.5	98.8	115	151	162	175	196
KPL 120 P	120	11.7	14.5	22.7	35.6	46.0	52.8	61.2	76.8	86.4	93.4	103	120	157	169	182	204
KPL 135 P	135	13.2	16.3	25.0	40.1	51.8	59.4	68.9	86.4	97.2	105	116	135	177	190	205	230
KPL 150 P	150	14.7	18.1	27.8	44.6	57.5	66.0	76.5	96.0	108	117	129	150	197	211	228	255
KPL 160 P	160	15.6	19.3	29.6	47.5	61.4	70.4	81.6	102	115	124	137	160	210	225	243	272
KPL 170 P	170	16.6	20.5	31.5	50.5	65.2	74.8	86.8	109	122	132	146	170	223	239	258	290
KPL 180 P	180	17.6	21.7	33.3	53.5	68.4	79.2	91.8	115	130	140	155	180	236	253	274	307
KPL 190 P	190	18.6	23.0	35.2	56.4	72.2	82.7	96.7	120	135	144	159	187	242	262	281	286
KPL 210 P	210	20.5	25.4	38.9	62.4	79.8	91.4	107	132	149	159	176	206	267	290	311	316
KPL 220 P	220	21.5	26.6	40.7	65.3	83.6	95.8	112	139	156	167	184	216	280	304	326	331
KPL 235 P	235	23.0	28.4	43.5	69.8	89.3	102	120	148	167	178	197	231	299	325	348	353
KPL 255 P	255	24.9	30.8	47.2	75.7	96.9	111	130	161	181	193	214	251	324	352	377	383
KPL 270 P	270	26.4	32.6	50.0	80.2	103	117	137	170	192	204	226	265	343	373	400	406
KPL 285 P	285	27.9	34.5	52.7	84.6	108	124	145	180	203	216	239	280	363	394	422	428
KPL 300 P	300	29.3	36.3	55.5	89.1	114	131	153	189	213	227	251	295	382	414	444	451
KPL 335 P	335	32.8	40.5	62.0	99.5	127	146	171	211	238	254	281	329	426	463	496	504
KPL 355 P	355	34.7	42.9	65.7	105	135	154	181	224	252	270	297	349	452	490	525	534
KPL 370 P	370	36.2	44.7	68.5	110	141	161	188	233	263	280	310	364	471	511	548	556
KPL 390 P	390	38.1	47.2	72.2	116	148	170	199	246	277	295	327	383	496	539	577	586
KPL 410 P	410	40.1	49.6	75.9	122	156	178	209	258	292	310	344	403	522	566	607	616
KPL 425 P	425	41.6	51.4	78.6	126	162	185	216	268	302	322	356	418	541	587	629	639
KPL 445 P	445	43.5	53.8	82.3	132	169	194	227	280	316	337	373	437	566	615	659	669
KPL 460 P	460	45.0	55.6	85.1	137	175	200	234	290	327	348	385	452	585	635	681	691
KPL 480 P	480	46.9	58.0	88.8	143	182	209	244	302	341	363	402	472	611	663	710	721

Cell Performance **L** range
 Performance fully charged with constant current charging

Final Voltage: 1.10V/cell

Available amperes at +20° C ± 5° C

Cell Type	C _s Ah	Hours							Minutes					Seconds			
		10	8	5	3	2	1.5	1	30	20	15	10	5	60	30	5	1
KPL 11 P	11	1.10	1.36	2.13	3.38	4.69	5.60	6.60	8.23	9.37	10.0	11.0	13.0	16.5	17.9	19.9	21.6
KPL 17 P	17	1.70	2.10	3.30	5.22	7.25	8.65	10.2	12.7	14.5	15.5	17.0	20.0	25.6	27.7	30.8	33.4
KPL 23 P	23	2.30	2.85	4.46	7.06	9.81	11.7	13.8	17.2	19.6	21.0	23.0	27.1	34.6	37.5	41.6	45.1
KPL 27 P	27	2.70	3.34	5.24	8.29	11.5	13.7	16.2	20.2	23.0	24.6	27.0	31.8	40.6	44.0	48.9	53.0
KPL 36 P	36	3.60	4.45	6.98	11.1	15.4	18.3	21.6	26.9	30.7	32.8	36.0	42.4	54.1	58.7	65.2	70.7
KPL 41 P	41	4.10	5.07	7.95	12.6	17.5	20.9	24.6	30.7	34.9	37.4	41.0	48.3	61.7	66.8	74.2	80.5
KPL 55 P	55	5.50	6.80	10.7	16.9	23.5	28.0	33.0	41.1	46.9	50.1	55.0	64.8	82.7	89.6	99.6	108
KPL 60 P	60	6.00	7.42	11.6	18.5	25.6	30.5	36.0	44.9	51.1	54.7	60.0	70.7	90.2	97.8	109	118
KPL 69 P	69	6.90	8.54	13.4	21.3	29.4	35.1	41.4	51.6	58.8	62.9	69.0	81.3	104	112	125	135
KPL 80 P	80	8.00	9.90	15.5	24.7	34.1	40.7	48.0	59.9	68.1	72.9	80.0	94.2	120	130	145	157
KPL 92 P	92	9.20	11.4	17.9	28.3	39.3	46.8	55.2	68.8	78.4	83.8	92.0	108	138	150	167	181
KPL 100 P	100	10.0	12.4	19.4	30.8	42.7	50.9	60.0	74.8	85.2	91.1	100	118	150	163	181	196
KPL 115 P	115	11.5	14.2	22.3	35.4	49.1	58.5	69.0	86.0	98.0	105	115	135	173	187	208	226
KPL 120 P	120	12.0	14.8	23.3	37.0	51.2	61.0	72.0	89.8	102	109	120	141	180	195	217	236
KPL 135 P	135	13.5	16.7	25.7	41.2	57.6	68.7	81.0	101	115	123	135	159	203	220	245	265
KPL 150 P	150	15.0	18.6	28.5	45.8	64.0	76.3	90.0	112	128	137	150	177	225	244	272	294
KPL 160 P	160	16.0	19.8	30.4	48.8	68.2	81.4	96.0	120	136	146	160	188	240	261	290	314
KPL 170 P	170	17.0	21.0	32.3	51.9	72.5	86.5	102	127	145	155	170	200	256	277	308	334
KPL 180 P	180	18.0	22.3	34.2	54.9	76.4	91.6	108	135	153	164	180	212	271	293	326	353
KPL 190 P	190	19.0	23.5	36.1	58.0	80.6	95.4	112	141	158	169	187	221	281	302	327	331
KPL 210 P	210	21.0	26.0	39.9	64.1	89.1	105	124	155	175	187	206	244	311	334	362	365
KPL 220 P	220	22.0	27.2	41.8	67.1	93.3	110	130	163	183	196	216	256	326	350	379	383
KPL 235 P	235	23.5	29.1	44.7	71.7	99.7	118	139	174	196	209	231	273	348	373	405	409
KPL 255 P	255	25.5	31.5	48.5	77.8	108	128	150	189	212	227	251	296	377	405	439	444
KPL 270 P	270	27.0	33.4	51.3	82.4	115	136	159	200	225	240	265	314	400	429	465	470
KPL 285 P	285	28.5	35.3	54.2	86.9	121	143	168	211	237	254	280	331	422	453	491	496
KPL 300 P	300	30.0	37.1	57.0	91.5	127	151	177	222	250	267	295	349	444	477	517	522
KPL 335 P	335	33.5	41.4	63.7	102	142	168	198	248	279	298	329	389	496	532	577	583
KPL 355 P	355	35.5	43.9	67.5	108	151	178	209	263	295	316	349	413	525	564	611	618
KPL 370 P	370	37.0	45.8	70.3	113	157	186	218	274	308	329	364	430	548	588	637	644
KPL 390 P	390	39.0	48.2	74.1	119	165	196	230	289	325	347	383	453	577	620	672	679
KPL 410 P	410	41.0	50.7	77.9	125	174	206	242	303	341	365	403	476	607	651	706	713
KPL 425 P	425	42.5	52.6	80.8	130	180	213	251	315	354	378	418	494	629	675	732	740
KPL 445 P	445	44.5	55.0	84.6	136	189	223	262	329	370	396	437	517	659	707	766	774
KPL 460 P	460	46.0	56.9	87.4	140	195	231	271	340	383	409	452	535	681	731	792	800
KPL 480 P	480	48.0	59.4	91.2	146	204	241	283	355	400	427	472	558	710	763	827	835

Cell Performance **L** range
 Performance fully charged with constant current charging

Final Voltage: 1.05V/cell

Available amperes at +20° C ± 5° C

Cell Type	C _s Ah	Hours							Minutes					Seconds			
		10	8	5	3	2	1.5	1	30	20	15	10	5	60	30	5	1
KPL 11 P	11	1.11	1.38	2.18	3.49	4.97	6.17	7.59	9.70	10.9	11.9	13.1	15.2	19.5	21.1	23.1	25.4
KPL 17 P	17	1.72	2.14	3.37	5.40	7.67	9.54	11.7	15.0	16.9	18.4	20.3	23.4	30.1	32.6	35.7	39.3
KPL 23 P	23	2.32	2.90	4.55	7.30	10.4	12.9	15.9	20.3	22.8	24.9	27.4	31.7	40.7	44.1	48.3	53.2
KPL 27 P	27	2.72	3.40	5.35	8.57	12.2	15.1	18.6	23.8	26.8	29.2	32.2	37.2	47.8	51.8	56.7	62.4
KPL 36 P	36	3.63	4.53	7.13	11.4	16.2	20.2	24.9	31.7	35.7	39.0	42.9	49.6	63.7	69.1	75.6	83.2
KPL 41 P	41	4.14	5.16	8.12	13.0	18.5	23.0	28.3	36.1	40.7	44.4	48.9	56.5	72.6	78.7	86.1	94.8
KPL 55 P	55	5.55	6.92	10.9	17.5	24.8	30.8	38.0	48.5	54.6	59.5	65.6	75.8	97.4	106	116	127
KPL 60 P	60	6.05	7.55	11.9	19.1	27.1	33.6	41.4	52.9	59.6	64.9	71.6	82.7	106	115	126	139
KPL 69 P	69	6.96	8.69	13.6	21.9	31.1	38.7	47.6	60.8	68.5	74.6	82.3	95.1	122	132	145	160
KPL 80 P	80	8.07	10.1	15.8	25.4	36.1	44.9	55.2	70.5	79.4	86.5	95.4	110	142	154	168	185
KPL 92 P	92	9.28	11.6	18.2	29.2	41.5	51.6	63.5	81.1	91.3	99.5	110	127	163	177	193	213
KPL 100 P	100	10.1	12.6	19.8	31.8	45.1	56.1	69.0	88.1	99.3	108	119	138	177	192	210	231
KPL 115 P	115	11.6	14.5	22.7	36.5	51.9	64.5	79.4	101	114	124	137	158	204	221	242	266
KPL 120 P	120	12.1	15.1	23.8	38.1	54.2	67.3	82.8	106	119	130	143	165	212	230	252	277
KPL 135 P	135	13.6	17.0	26.5	42.5	60.9	75.7	93.2	119	134	146	161	186	239	259	284	312
KPL 150 P	150	15.1	18.9	29.4	47.3	67.7	84.2	104	132	149	162	179	207	266	288	315	347
KPL 160 P	160	16.1	20.1	31.4	50.4	72.2	89.8	110	141	159	173	191	220	283	307	336	370
KPL 170 P	170	17.2	21.4	33.3	53.6	76.7	95.3	117	150	169	184	203	234	301	326	357	393
KPL 180 P	180	18.2	22.7	35.3	56.7	81.1	101	124	159	179	195	215	248	319	345	378	416
KPL 190 P	190	19.2	23.9	37.2	59.9	85.6	106	130	164	184	200	222	257	327	354	395	420
KPL 210 P	210	21.2	26.4	41.2	66.2	94.6	117	143	181	204	221	245	284	362	391	437	464
KPL 220 P	220	22.2	27.7	43.1	69.3	99.1	123	150	189	214	231	257	298	379	409	458	486
KPL 235 P	235	23.7	29.6	46.1	74.0	106	131	160	202	228	247	274	318	405	437	489	519
KPL 255 P	255	25.7	32.1	50.0	80.3	115	142	174	220	248	268	298	345	439	475	530	563
KPL 270 P	270	27.2	34.0	52.9	85.1	122	151	184	232	262	284	315	365	465	502	562	596
KPL 285 P	285	28.8	35.9	55.9	89.8	128	159	194	245	277	299	333	386	491	530	593	629
KPL 300 P	300	30.3	37.8	58.8	94.5	135	167	205	258	291	315	350	406	517	558	624	662
KPL 335 P	335	33.8	42.2	65.7	106	151	187	228	288	325	352	391	453	577	623	697	740
KPL 355 P	355	35.8	44.7	69.6	112	160	198	242	306	345	373	415	480	611	661	738	784
KPL 370 P	370	37.3	46.6	72.5	117	167	206	252	319	359	389	432	500	637	689	770	817
KPL 390 P	390	39.4	49.1	76.4	123	176	218	266	336	379	410	456	528	672	726	811	861
KPL 410 P	410	41.4	51.6	80.4	129	185	229	280	353	398	431	479	555	706	763	853	905
KPL 425 P	425	42.9	53.5	83.3	134	191	237	290	366	413	446	496	575	732	791	884	938
KPL 445 P	445	44.9	56.0	87.2	140	200	248	303	383	432	467	520	602	766	828	926	983
KPL 460 P	460	46.4	57.9	90.2	145	207	257	314	396	447	483	537	622	792	856	957	1016
KPL 480 P	480	48.4	60.4	94.1	151	216	268	327	413	466	504	561	649	827	893	998	1060

Cell Performance **L** range

Performance fully charged with constant current charging

Final Voltage: 1.00V/cell

Available amperes at +20° C ± 5° C

Cell Type	C _s Ah	Hours							Minutes					Seconds			
		10	8	5	3	2	1.5	1	30	20	15	10	5	60	30	5	1
KPL 11 P	11	1.12	1.39	2.20	3.56	5.12	6.47	8.47	10.9	12.5	13.4	15.0	17.3	22.2	24.1	27.0	29.2
KPL 17 P	17	1.74	2.15	3.40	5.51	7.91	10.0	13.1	16.9	19.3	20.8	23.2	26.7	34.4	37.3	41.7	45.1
KPL 23 P	23	2.35	2.91	4.60	7.45	10.7	13.5	17.7	22.8	26.1	28.1	31.3	36.1	46.5	50.4	56.4	61.0
KPL 27 P	27	2.76	3.42	5.40	8.75	12.6	15.9	20.8	26.8	30.6	33.0	36.8	42.4	54.6	59.2	66.2	71.6
KPL 36 P	36	3.68	4.56	7.20	11.7	16.7	21.2	27.7	35.7	40.8	44.0	49.1	56.5	72.8	78.9	88.2	95.5
KPL 41 P	41	4.19	5.19	8.20	13.3	19.1	24.1	31.6	40.7	46.5	50.1	55.9	64.4	82.9	89.9	100	109
KPL 55 P	55	5.62	6.96	11.0	17.8	25.6	32.3	42.4	54.6	62.3	67.2	75.0	86.4	111	121	135	146
KPL 60 P	60	6.13	7.60	12.0	19.4	27.9	35.3	46.2	59.6	68.0	73.3	81.8	94.2	121	132	147	159
KPL 69 P	69	7.05	8.74	13.8	22.3	32.1	40.6	53.2	68.5	78.2	84.3	94.0	108	140	151	169	183
KPL 80 P	80	8.18	10.1	16.0	25.9	37.2	47.1	61.6	79.4	90.7	97.8	109	126	162	175	196	212
KPL 92 P	92	9.40	11.7	18.4	29.8	42.8	54.1	70.9	91.3	104	112	125	144	186	202	225	244
KPL 100 P	100	10.2	12.7	20.0	32.4	46.5	58.8	77.0	99.3	113	122	136	157	202	219	245	265
KPL 115 P	115	11.8	14.6	23.0	37.2	53.5	67.6	88.6	114	130	141	157	181	233	252	282	305
KPL 120 P	120	12.3	15.2	24.0	38.9	55.8	70.6	92.4	119	136	147	164	188	243	263	294	318
KPL 135 P	135	13.8	17.1	27.0	43.7	62.8	79.4	104	134	153	165	184	212	273	296	331	358
KPL 150 P	150	15.3	19.0	30.0	48.5	69.8	88.2	116	149	170	183	204	236	303	329	368	398
KPL 160 P	160	16.4	20.3	32.0	51.8	74.4	94.1	123	159	181	196	218	251	324	351	392	424
KPL 170 P	170	17.4	21.5	34.0	55.0	79.1	100	131	169	193	208	232	267	344	373	417	451
KPL 180 P	180	18.4	22.8	36.0	58.3	83.5	106	135	179	204	220	245	283	364	395	441	477
KPL 190 P	190	19.4	24.1	38.0	61.5	88.2	111	143	185	211	228	253	291	374	404	455	471
KPL 210 P	210	21.5	26.6	42.0	68.0	97.4	123	158	204	233	253	279	322	414	447	503	521
KPL 220 P	220	22.5	27.9	44.0	71.2	102	128	165	214	244	265	293	337	434	468	527	546
KPL 235 P	235	24.0	29.8	47.0	76.0	109	137	177	228	261	283	313	360	463	500	563	583
KPL 255 P	255	26.1	32.3	51.0	82.5	118	149	192	248	283	307	339	390	503	542	611	632
KPL 270 P	270	27.6	34.2	54.0	87.4	125	158	203	262	300	325	359	413	532	574	647	670
KPL 285 P	285	29.1	36.1	57.0	92.2	132	166	214	277	316	343	379	436	562	606	683	707
KPL 300 P	300	30.7	38.0	60.0	97.1	139	175	225	291	333	361	399	459	591	638	719	744
KPL 335 P	335	34.2	42.4	67.0	108	155	196	252	325	372	403	446	513	660	713	802	831
KPL 355 P	355	36.3	44.9	71.0	115	165	207	267	345	394	427	472	544	700	755	850	880
KPL 370 P	370	37.8	46.8	74.0	120	172	216	278	359	411	445	492	566	729	787	886	918
KPL 390 P	390	39.9	49.4	78.0	126	181	228	293	379	433	469	519	597	769	830	934	967
KPL 410 P	410	41.9	51.9	82.0	133	190	239	308	398	455	493	545	628	808	872	982	1017
KPL 425 P	425	43.4	53.8	85.0	138	197	248	319	413	472	511	565	651	838	904	1018	1054
KPL 445 P	445	45.5	56.3	89.0	144	206	260	334	432	494	535	592	681	877	947	1066	1104
KPL 460 P	460	47.0	58.2	92.0	149	213	269	346	447	511	553	612	704	907	978	1102	1141
KPL 480 P	480	49.1	60.8	96.0	155	223	280	361	466	533	577	638	735	946	1021	1150	1190

Cell Performance L range

Performance after long term floating with constant voltage charging

Final Voltage: 1.14V/cell

Available amperes at +20° C ± 5° C

Cell Type	C ₅ Ah	Hours							Minutes					Seconds			
		10	8	5	3	2	1.5	1	30	20	15	10	5	60	30	5	1
KPL 11 P	11	1.08	1.33	2.07	3.12	3.69	4.02	4.29	4.89	5.27	5.69	6.24	7.17	9.37	10.1	10.9	12.2
KPL 17 P	17	1.66	2.06	3.20	4.82	5.70	6.21	6.63	7.56	8.14	8.80	9.64	11.1	14.5	15.5	16.8	18.8
KPL 23 P	23	2.25	2.78	4.32	6.52	7.72	8.40	8.97	10.2	11.0	11.9	13.0	15.0	19.6	21.0	22.7	25.5
KPL 27 P	27	2.64	3.26	5.08	7.66	9.06	9.86	10.5	12.0	12.9	14.0	15.3	17.6	23.0	24.7	26.7	29.9
KPL 36 P	36	3.52	4.35	6.77	10.2	12.1	13.1	14.0	16.0	17.2	18.6	20.4	23.5	30.7	32.9	35.6	39.9
KPL 41 P	41	4.01	4.96	7.71	11.6	13.8	15.0	16.0	18.2	19.6	21.2	23.2	26.7	34.9	37.5	40.5	45.4
KPL 55 P	55	5.38	6.65	10.4	15.6	18.5	20.1	21.5	24.5	26.3	28.5	31.2	35.9	46.9	50.3	54.3	60.9
KPL 60 P	60	5.87	7.25	11.3	17.0	20.1	21.9	23.4	26.7	28.7	31.0	34.1	39.1	51.1	54.9	59.3	66.4
KPL 69 P	69	6.75	8.34	13.0	19.6	23.2	25.2	26.9	30.7	33.0	35.7	39.1	45.0	58.8	63.1	68.2	76.4
KPL 80 P	80	7.82	9.67	15.1	22.7	26.8	29.2	31.2	35.6	38.3	41.4	45.4	52.2	68.2	73.2	79.0	88.6
KPL 92 P	92	9.00	11.1	17.4	26.1	30.9	33.6	36.0	40.9	44.0	47.6	52.2	60.0	78.4	84.1	90.9	102
KPL 100 P	100	9.78	12.1	18.9	28.4	33.6	36.5	39.0	44.5	47.9	51.7	56.7	65.2	85.2	91.5	98.8	111
KPL 115 P	115	11.2	13.9	21.7	32.6	38.6	42.0	44.9	51.2	55.1	59.5	65.2	75.0	98.0	105	114	127
KPL 120 P	120	11.7	14.5	22.7	34.0	40.3	43.8	46.8	53.4	57.5	62.1	68.0	78.2	102	110	119	133
KPL 135 P	135	13.2	16.3	25.0	38.3	45.3	49.3	52.7	60.0	64.6	69.8	76.5	88.0	115	123	133	149
KPL 150 P	150	14.7	18.1	27.8	42.5	50.3	54.8	58.5	66.7	71.8	77.6	85.0	97.8	128	137	148	166
KPL 160 P	160	15.6	19.3	29.6	45.4	53.7	58.4	62.4	71.2	76.6	82.8	90.7	104	136	146	158	177
KPL 170 P	170	16.6	20.5	31.5	48.2	57.0	62.1	66.4	75.6	81.4	88.0	96.4	111	145	155	168	188
KPL 180 P	180	17.6	21.7	33.3	51.1	59.9	65.7	70.2	80.1	86.2	93.1	102	117	153	165	178	199
KPL 190 P	190	18.6	23.0	35.2	53.9	63.2	68.6	74.0	83.2	89.8	95.6	105	122	157	171	183	186
KPL 210 P	210	20.5	25.4	38.9	59.6	69.8	75.8	81.8	91.9	99.3	106	116	135	174	189	202	205
KPL 220 P	220	21.5	26.6	40.7	62.4	73.2	79.5	85.7	96.3	104	111	122	141	182	197	212	215
KPL 235 P	235	23.0	28.4	43.5	66.7	78.1	84.8	91.5	103	111	118	130	151	194	211	226	230
KPL 255 P	255	24.9	30.8	47.2	72.3	84.8	92.1	99.3	112	121	128	141	163	211	229	245	249
KPL 270 P	270	26.4	32.6	50.0	76.6	89.8	97.5	105	118	128	136	149	173	223	242	260	264
KPL 285 P	285	27.9	34.5	52.7	80.8	94.8	103	111	125	135	143	158	183	236	256	274	278
KPL 300 P	300	29.3	36.3	55.5	85.1	99.8	108	117	131	142	151	166	192	248	269	289	293
KPL 335 P	335	32.8	40.5	62.0	95.0	111	121	130	147	158	169	185	215	277	301	322	327
KPL 355 P	355	34.7	42.9	65.7	101	118	128	138	155	168	179	196	228	294	319	342	347
KPL 370 P	370	36.2	44.7	68.5	105	123	134	144	162	175	186	205	237	306	332	356	361
KPL 390 P	390	38.1	47.2	72.2	111	130	141	152	171	184	196	216	250	322	350	375	381
KPL 410 P	410	40.1	49.6	75.9	116	136	148	160	180	194	206	227	263	339	368	394	401
KPL 425 P	425	41.6	51.4	78.6	121	141	153	165	186	201	214	235	272	351	382	409	415
KPL 445 P	445	43.5	53.8	82.3	126	148	161	173	195	210	224	246	285	368	399	428	435
KPL 460 P	460	45.0	55.6	85.1	130	153	166	179	201	217	232	254	295	380	413	443	449
KPL 480 P	480	46.9	58.0	88.8	136	160	173	187	210	227	242	265	308	397	431	462	469

Cell Performance L range

Performance after long term floating with constant voltage charging

Final Voltage: 1.10V/cell

Available amperes at +20° C ± 5° C

Cell Type	C ₅ Ah	Hours							Minutes					Seconds			
		10	8	5	3	2	1.5	1	30	20	15	10	5	60	30	5	1
KPL 11 P	11	1.10	1.36	2.13	3.30	4.32	4.90	5.38	6.21	6.84	7.22	7.81	9.07	11.5	12.5	13.8	15.0
KPL 17 P	17	1.70	2.10	3.30	5.10	6.67	7.57	8.31	9.60	10.6	11.2	12.1	14.0	17.8	19.2	21.4	23.2
KPL 23 P	23	2.30	2.85	4.46	6.90	9.02	10.2	11.2	13.0	14.3	15.1	16.3	19.0	24.0	26.0	28.9	31.4
KPL 27 P	27	2.70	3.34	5.24	8.10	10.6	12.0	13.2	15.2	16.8	17.7	19.2	22.3	28.2	30.6	34.0	36.8
KPL 36 P	36	3.60	4.45	6.98	10.8	14.1	16.0	17.6	20.3	22.4	23.6	25.6	29.7	37.6	40.8	45.3	49.1
KPL 41 P	41	4.10	5.07	7.95	12.3	16.1	18.2	20.0	23.2	25.5	26.9	29.1	33.8	42.9	46.4	51.6	55.9
KPL 55 P	55	5.50	6.80	10.7	16.5	21.6	24.5	26.9	31.1	34.2	36.1	39.1	45.4	57.5	62.3	69.2	75.0
KPL 60 P	60	6.00	7.42	11.6	18.1	23.5	26.7	29.3	33.9	37.3	39.4	42.6	49.5	62.7	68.0	75.5	81.9
KPL 69 P	69	6.90	8.54	13.4	20.8	27.1	30.7	33.7	39.0	42.9	45.3	49.0	56.9	72.1	78.1	86.8	94.1
KPL 80 P	80	8.00	9.90	15.5	24.2	31.4	35.6	39.1	45.2	49.7	52.5	56.8	66.0	83.6	90.6	101	109
KPL 92 P	92	9.20	11.4	17.9	27.7	36.1	41.0	45.0	52.0	57.2	60.3	65.3	75.9	96.1	104	116	126
KPL 100 P	100	10.0	12.4	19.4	30.1	39.2	44.5	48.9	56.5	62.2	65.6	71.0	82.5	104	113	126	136
KPL 115 P	115	11.5	14.2	22.3	34.6	45.2	51.2	56.2	64.9	71.5	75.5	81.7	94.8	120	130	145	157
KPL 120 P	120	12.0	14.8	23.3	36.1	47.1	53.4	58.7	67.8	74.6	78.8	85.2	99.0	125	136	151	164
KPL 135 P	135	13.5	16.7	25.7	40.2	53.0	60.1	66.0	76.2	83.9	88.6	95.9	111	141	153	170	184
KPL 150 P	150	15.0	18.6	28.5	44.7	58.9	66.8	73.4	84.7	93.3	98.5	107	124	157	170	189	205
KPL 160 P	160	16.0	19.8	30.4	47.7	62.8	71.2	78.2	90.4	99.5	105	114	132	167	181	201	218
KPL 170 P	170	17.0	21.0	32.3	50.7	66.7	75.7	83.1	96.0	106	112	121	140	178	192	214	232
KPL 180 P	180	18.0	22.3	34.2	53.6	70.2	80.1	88.0	102	112	118	128	148	188	204	226	246
KPL 190 P	190	19.0	23.5	36.1	56.6	74.2	83.5	91.3	106	115	122	133	155	195	210	227	230
KPL 210 P	210	21.0	26.0	39.9	62.6	82.0	92.2	101	117	128	135	147	171	216	232	251	254
KPL 220 P	220	22.0	27.2	41.8	65.6	85.9	96.6	106	123	134	141	154	179	226	243	263	266
KPL 235 P	235	23.5	29.1	44.7	70.0	91.7	103	113	131	143	151	164	191	242	260	281	284
KPL 255 P	255	25.5	31.5	48.5	76.0	99.5	112	123	142	155	163	178	207	262	282	305	308
KPL 270 P	270	27.0	33.4	51.3	80.5	105	119	130	151	164	173	188	220	278	298	323	327
KPL 285 P	285	28.5	35.3	54.2	84.9	111	125	137	159	173	183	199	232	293	315	341	345
KPL 300 P	300	30.0	37.1	57.0	89.4	117	132	144	168	182	195	209	244	309	331	359	363
KPL 335 P	335	33.5	41.4	63.7	99.8	131	147	161	187	204	215	234	272	345	370	401	405
KPL 355 P	355	35.5	43.9	67.5	106	139	156	171	198	216	227	248	289	365	392	425	429
KPL 370 P	370	37.0	45.8	70.3	110	144	163	178	207	225	237	258	301	381	409	443	447
KPL 390 P	390	39.0	48.2	74.1	116	152	171	187	218	237	250	272	317	401	431	467	472
KPL 410 P	410	41.0	50.7	77.9	122	160	180	197	229	249	263	286	333	422	453	491	496
KPL 425 P	425	42.5	52.6	80.8	127	166	187	204	237	258	272	297	346	437	469	509	514
KPL 445 P	445	44.5	55.0	84.6	133	174	195	214	249	270	285	311	362	458	491	533	538
KPL 460 P	460	46.0	56.9	87.4	137	180	202	221	257	279	295	321	374	473	508	551	556
KPL 480 P	480	48.0	59.4	91.2	143	187	211	231	268	292	308	335	390	494	530	574	580

Cell Performance L range

Performance after long term floating with constant voltage charging

Final Voltage: 1.05V/cell

Available amperes at +20° C ± 5° C

Cell Type	C ₅ Ah	Hours							Minutes					Seconds			
		10	8	5	3	2	1.5	1	30	20	15	10	5	60	30	5	1
KPL 11 P	11	1.11	1.38	2.18	3.49	4.72	5.65	6.53	7.76	8.51	9.11	9.90	11.3	14.3	15.5	17.0	18.7
KPL 17 P	17	1.72	2.14	3.37	5.40	7.29	8.73	10.1	12.0	13.2	14.1	15.3	17.5	22.1	24.0	26.2	28.9
KPL 23 P	23	2.32	2.90	4.55	7.30	9.86	11.8	13.6	16.2	17.8	19.0	20.7	23.6	29.9	32.4	35.5	39.1
KPL 27 P	27	2.72	3.40	5.35	8.57	11.6	13.9	16.0	19.0	20.9	22.3	24.3	27.7	35.1	38.1	41.7	45.9
KPL 36 P	36	3.63	4.53	7.13	11.4	15.4	18.5	21.4	25.4	27.9	29.8	32.4	37.0	46.8	50.8	55.6	61.2
KPL 41 P	41	4.14	5.16	8.12	13.0	17.6	21.0	24.3	28.9	31.7	33.9	36.9	42.1	53.3	57.8	63.3	69.7
KPL 55 P	55	5.55	6.92	10.9	17.5	23.6	28.2	32.6	38.8	42.6	45.5	49.5	56.5	71.6	77.6	84.9	93.5
KPL 60 P	60	6.05	7.55	11.9	19.1	25.7	30.7	35.6	42.3	46.5	49.7	54.0	61.6	78.1	84.6	92.6	102
KPL 69 P	69	6.96	8.69	13.6	21.9	29.6	35.4	40.9	48.7	53.4	57.1	62.1	70.8	89.8	97.3	107	117
KPL 80 P	80	8.07	10.1	15.8	25.4	34.3	41.1	47.5	56.4	61.9	66.2	72.0	82.1	104	113	123	136
KPL 92 P	92	9.28	11.6	18.2	29.2	39.5	47.2	54.6	64.9	71.2	76.2	82.8	94.4	120	130	142	156
KPL 100 P	100	10.1	12.6	19.8	31.8	42.9	51.3	59.3	70.5	77.5	82.8	90.0	103	130	141	154	170
KPL 115 P	115	11.6	14.5	22.7	36.5	49.3	59.0	68.2	81.1	89.0	95.2	104	118	150	162	178	195
KPL 120 P	120	12.1	15.1	23.8	38.1	51.5	61.6	71.2	84.6	92.9	99.3	108	123	156	169	185	204
KPL 135 P	135	13.6	17.0	26.5	42.5	57.9	69.3	80.1	95.2	104	112	122	139	176	190	208	229
KPL 150 P	150	15.1	18.9	29.4	47.3	64.3	77.0	89.0	106	116	124	135	154	195	212	232	255
KPL 160 P	160	16.1	20.1	31.4	50.4	68.6	82.1	94.9	113	124	132	144	164	208	226	247	272
KPL 170 P	170	17.2	21.4	33.3	53.6	72.9	87.2	101	120	132	141	153	175	221	240	262	289
KPL 180 P	180	18.2	22.7	35.3	56.7	77.0	92.2	107	127	139	149	162	185	234	254	278	306
KPL 190 P	190	19.2	23.9	37.2	59.9	81.3	97.0	111	131	144	153	168	191	240	260	290	308
KPL 210 P	210	21.2	26.4	41.2	66.2	89.9	107	123	145	159	169	185	212	266	287	321	341
KPL 220 P	220	22.2	27.7	43.1	69.3	94.2	112	129	152	167	177	194	222	278	301	336	357
KPL 235 P	235	23.7	29.6	46.1	74.0	101	120	138	162	178	189	207	237	297	321	359	381
KPL 255 P	255	25.7	32.1	50.0	80.3	109	130	150	176	193	205	225	257	323	349	390	414
KPL 270 P	270	27.2	34.0	52.9	85.1	116	138	158	186	204	217	238	272	342	369	413	438
KPL 285 P	285	28.8	35.9	55.9	89.8	122	146	167	196	216	229	251	287	361	390	436	463
KPL 300 P	300	30.3	37.8	58.8	94.5	128	153	176	207	227	241	265	302	380	410	459	487
KPL 335 P	335	33.8	42.2	65.7	106	143	171	196	231	254	269	295	338	424	458	512	544
KPL 355 P	355	35.8	44.7	69.6	112	152	181	208	245	269	285	313	358	449	486	543	576
KPL 370 P	370	37.3	46.6	72.5	117	158	189	217	255	280	297	326	373	468	506	566	600
KPL 390 P	390	39.4	49.1	76.4	123	167	199	229	269	295	313	344	393	494	533	596	633
KPL 410 P	410	41.4	51.6	80.4	129	175	209	240	282	311	329	362	413	519	561	627	665
KPL 425 P	425	42.9	53.5	83.3	134	182	217	249	293	322	341	375	428	538	581	650	690
KPL 445 P	445	44.9	56.0	87.2	140	190	227	261	307	337	357	392	448	563	609	680	722
KPL 460 P	460	46.4	57.9	90.2	145	197	235	270	317	348	369	406	464	582	629	703	747
KPL 480 P	480	48.4	60.4	94.1	151	205	245	282	331	364	386	423	484	608	657	734	779

Cell Performance L range

Performance after long term floating with constant voltage charging

Final Voltage: 1.00V/cell

Available amperes at +20° C ± 5° C

Cell Type	C _s Ah	Hours							Minutes					Seconds			
		10	8	5	3	2	1.5	1	30	20	15	10	5	60	30	5	1
KPL 11 P	11	1.12	1.39	2.20	3.56	4.91	6.13	7.62	9.17	10.2	10.9	12.0	13.8	17.6	19.0	21.3	23.0
KPL 17 P	17	1.74	2.15	3.40	5.51	7.59	9.48	11.8	14.2	15.8	16.8	18.6	21.3	27.2	29.4	32.9	35.6
KPL 23 P	23	2.35	2.91	4.60	7.45	10.3	12.8	15.9	19.2	21.4	22.8	25.2	28.8	36.8	39.8	44.5	48.2
KPL 27 P	27	2.76	3.42	5.40	8.75	12.1	15.1	18.7	22.5	25.1	26.7	29.6	33.8	43.2	46.8	52.3	56.5
KPL 36 P	36	3.68	4.56	7.20	11.7	16.1	20.1	24.9	30.0	33.5	35.6	39.4	45.0	57.5	62.3	69.7	75.4
KPL 41 P	41	4.19	5.19	8.20	13.3	18.3	22.9	28.4	34.2	38.1	40.6	44.9	51.3	65.5	71.0	79.4	85.9
KPL 55 P	55	5.62	6.96	11.0	17.8	24.6	30.7	38.1	45.8	51.1	54.4	60.2	68.8	87.9	95.2	106	115
KPL 60 P	60	6.13	7.60	12.0	19.4	26.8	33.4	41.6	50.0	55.8	59.4	65.7	75.1	95.9	104	116	126
KPL 69 P	69	7.05	8.74	13.8	22.3	30.8	38.5	47.9	57.6	64.2	68.3	75.5	86.3	110	119	134	145
KPL 80 P	80	8.18	10.1	16.0	25.9	35.7	44.7	55.4	66.7	74.4	79.2	87.6	100	128	139	155	168
KPL 92 P	92	9.40	11.7	18.4	29.8	41.1	51.3	63.8	76.7	85.5	91.1	101	115	147	159	178	193
KPL 100 P	100	10.2	12.7	20.0	32.4	44.6	55.7	69.3	83.4	93.0	99.0	109	125	160	173	194	209
KPL 115 P	115	11.8	14.6	23.0	37.2	51.3	64.1	79.7	95.8	107	114	126	144	184	199	223	241
KPL 120 P	120	12.3	15.2	24.0	38.9	53.6	66.9	83.2	100	112	119	131	150	192	208	232	251
KPL 135 P	135	13.8	17.1	27.0	43.7	60.3	75.3	93.6	112	126	134	148	169	216	234	261	283
KPL 150 P	150	15.3	19.0	30.0	48.5	67.0	83.6	104	125	139	148	164	188	240	260	290	314
KPL 160 P	160	16.4	20.3	32.0	51.8	71.4	89.2	111	133	149	158	175	200	256	277	310	335
KPL 170 P	170	17.4	21.5	34.0	55.0	75.9	94.8	118	142	158	168	186	213	272	294	329	356
KPL 180 P	180	18.4	22.8	36.0	58.3	80.2	100	122	150	167	178	197	225	288	312	348	377
KPL 190 P	190	19.4	24.1	38.0	61.5	84.6	105	129	155	173	185	203	232	296	319	359	372
KPL 210 P	210	21.5	26.6	42.0	68.0	93.5	116	142	171	191	205	224	256	327	353	397	411
KPL 220 P	220	22.5	27.9	44.0	71.2	98.0	122	149	180	200	214	235	268	343	370	416	431
KPL 235 P	235	24.0	29.8	47.0	76.0	105	130	159	192	214	229	251	287	366	395	445	460
KPL 255 P	255	26.1	32.3	51.0	82.5	114	142	172	208	232	248	272	311	397	428	482	500
KPL 270 P	270	27.6	34.2	54.0	87.4	120	149	183	220	246	263	288	329	420	454	511	529
KPL 285 P	285	29.1	36.1	57.0	92.2	127	158	193	233	259	278	304	348	444	479	539	558
KPL 300 P	300	30.7	38.0	60.0	97.1	134	166	203	245	273	292	320	366	467	504	568	588
KPL 335 P	335	34.2	42.4	67.0	108	149	185	227	273	305	326	358	409	522	563	634	656
KPL 355 P	355	36.3	44.9	71.0	115	158	197	240	290	323	346	379	433	553	597	672	696
KPL 370 P	370	37.8	46.8	74.0	120	165	205	250	302	337	360	395	451	576	622	700	725
KPL 390 P	390	39.9	49.4	78.0	126	174	216	264	318	355	380	417	476	607	655	738	764
KPL 410 P	410	41.9	51.9	82.0	133	183	227	277	335	373	399	438	500	638	689	776	803
KPL 425 P	425	43.4	53.8	85.0	138	189	235	287	347	387	414	454	519	662	714	804	833
KPL 445 P	445	45.5	56.3	89.0	144	198	246	301	363	405	433	475	543	693	748	842	872
KPL 460 P	460	47.0	58.2	92.0	149	205	255	311	375	419	448	491	561	716	773	870	901
KPL 480 P	480	49.1	60.8	96.0	155	214	266	325	392	437	468	513	586	747	807	908	940

2 step, 1 tier rack

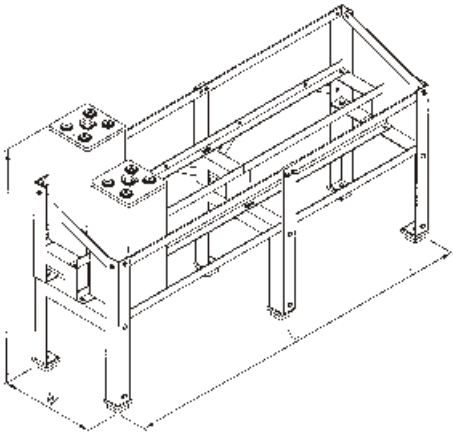

2 step, 2 tier rack

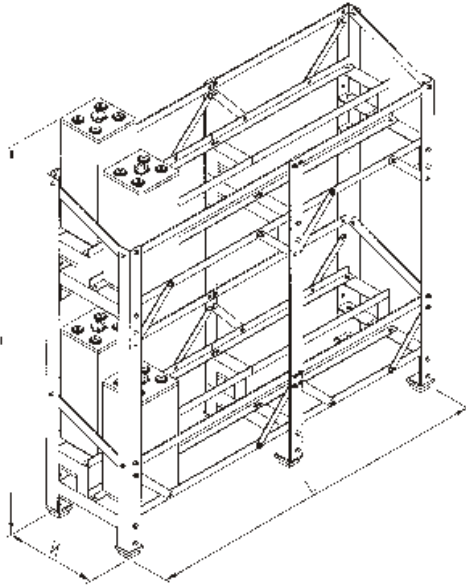

3 step, 1 tier rack

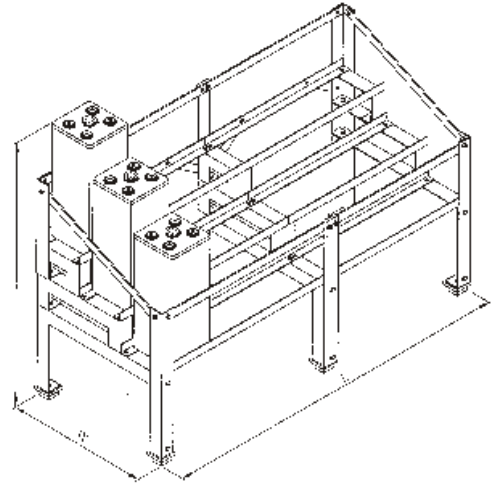

BATTERY RACK DIMENSIONS

For safe and reliable operation, batteries should be mounted on suitable battery racks. HBL NIFE battery racks are made of alkali-resistant, powder coated steel sections. Battery racks are available in multi-step one tier or multi-step two tier configuration. Standard battery racks are supplied in knocked-down condition and can be easily assembled at site.

Container size reference	1Tier								2Tier								
	1STEP		2STEP		3STEP		4STEP		1STEP		2STEP		3STEP		4STEP		
	W	H	W	H	W	H	W	H	W	H	W	H	W	H	W	H	
Single Cells (Normal arrangement)																	
1&2			222	668	323	783	424	898									
3			318	678	467	793	616	908	318	1070	467	1300	616	1550			
4			318	728	467	843	616	958	318	1250	467	1450	616	1700			
5			318	813	467	928	616	1043	318	1450	467	1670	616	1900			
6			318	830	467	945	616	1060	318	1470	467	1700	616	1950			
7			368	856	542	971	716	1086	368	1550	542	1760	716	2000			
8			376	882	554	997	732	1112	376	1650	554	1860	732	2100			

(All dimensions in mm)

Evaluation of length

$$\begin{aligned} \text{Length of rack} &= (X + 1) \times \text{No. Of cells in a row for (S1-S5)} \\ &= (X + 2) \times \text{No. Of cells in a row for (S6-S8)} \end{aligned}$$

Where, X = Length of Cell (i.e for S1-S8)

The value of length should be rounded off to nearest to 50 and 5 mm should be added.

Note : Height is including cells

3 step, 2 tier rack

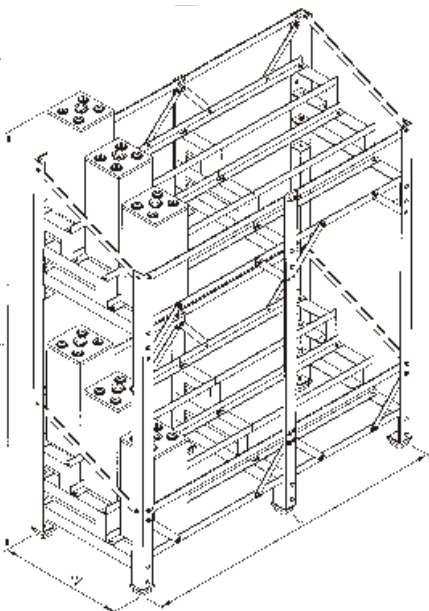

4 step, 1 tier rack

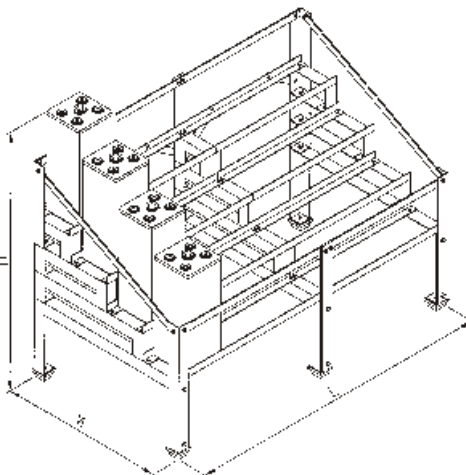

4 step, 2 tier rack

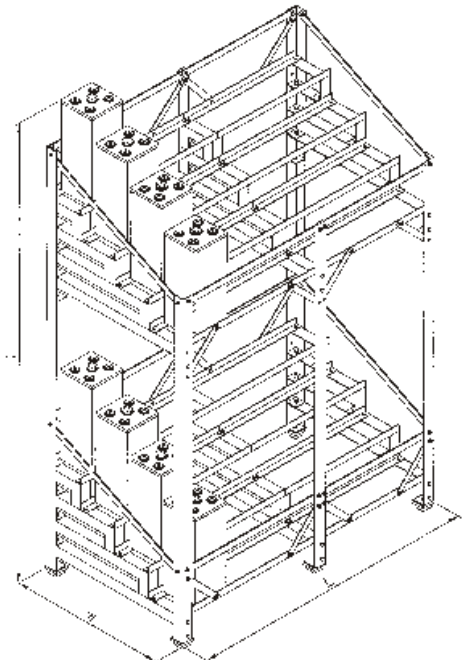

Typical Characteristics

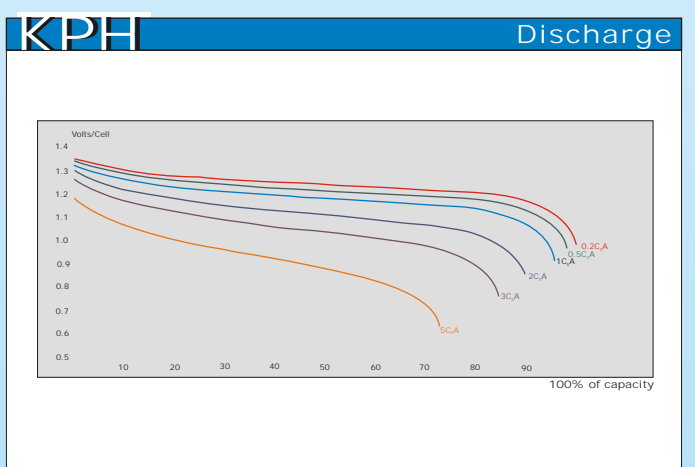
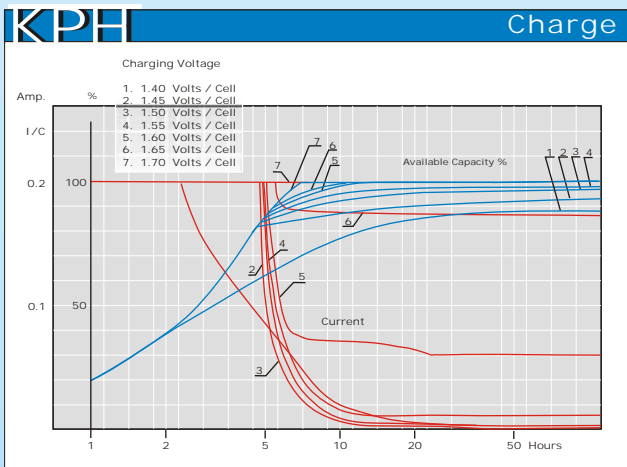
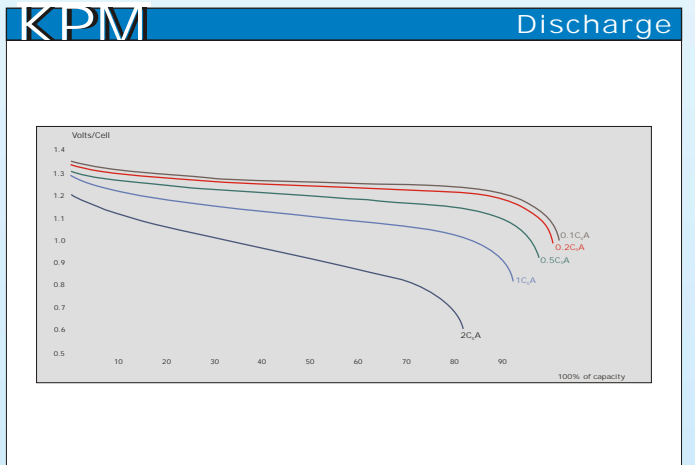
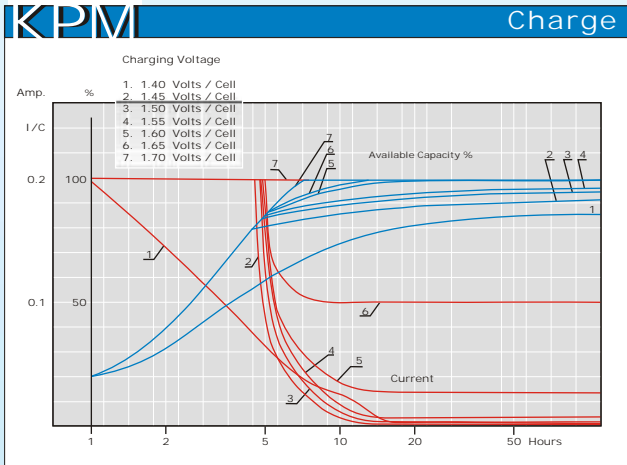
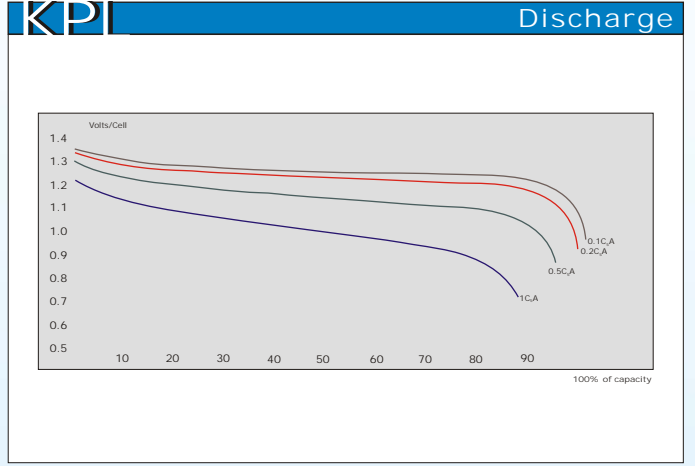
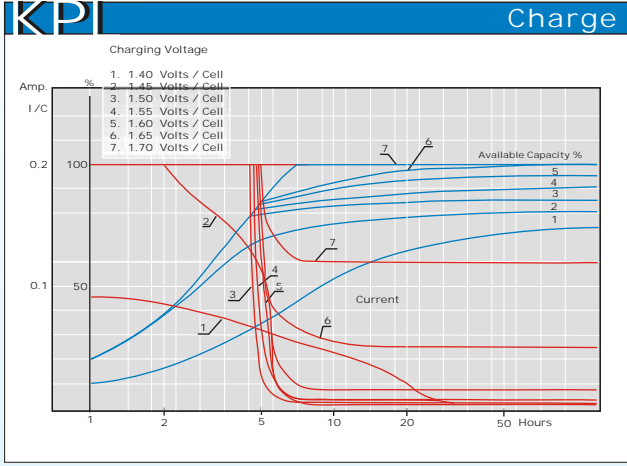



STQC Directorate,
Department of Electronics,
Government of India



ISO 9001-2000 Certified



IEC - 60623

EMS ISO 14001 - 1996 Certified

HBLNIFE

HBL NIFE Power Systems Limited

Road # 10, Banjara Hills, Hyderabad - 500 034. INDIA

E-mail: contact@hblnife.com

www.hblnife.com