

NCPP

Nickel Cadmium Pocket Plate Batteries

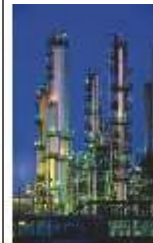

Block Battery Dimensional and Electrical Data



Nickel Cadmium Pocket Plate Batteries

HBL's Nickel Cadmium Pocket Plate Battery designs are based on the superior Pocket Plate technology of SABNIFE AB, Sweden.

The first electrode design for Nickel Cadmium Batteries employed the pocket plate construction which is still considered to be the most reliable design.

The fully integrated modern factory, supported by strong process management and quality controls makes HBL one of the best Nickel Cadmium Battery production facilities in the world.

HBL's NCPP Block Batteries are available as Blocks (of individual cells thermally welded together) of multiple voltages & capacities.



IEC/EN 60623

Designed to perfection, built to last

The Superior constructional features of the HBL's Nickel Cadmium Pocket Plate Battery, makes it a reliable product for any application

Construction

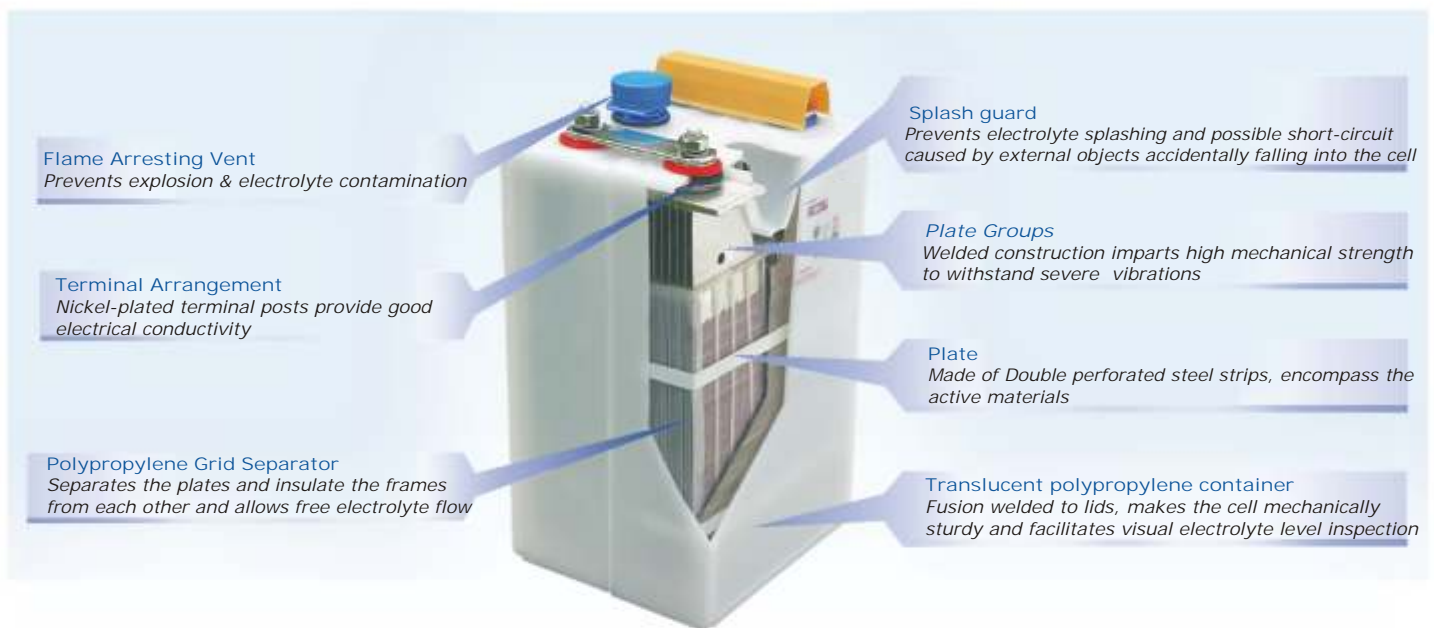

Product Range

HBL's NCPP Block Batteries are available in three types designated KBH, KBM & KBL based on performance characteristics. The wide capacity range in each type permit selection of an optimum battery for any application.

KBH Range

- Thin plates
- Greatest Plate area per amount of active material
- High Performance for short discharge times

KBM Range

- Optimised plate thickness
- Balance between High Rate and Low Rate
- Ideal for medium discharge times

KBL Range

- Thick plates
- Greatest amount of active material per plate area
- Low currents for long discharge times

Outstanding Advantages of HBL's batteries are:

- ✦ Highest reliability among all battery systems.
- ✦ Unsurpassed resistance to electrical and mechanical abuse.
- ✦ Long service life.
- ✦ Very good charge retention.
- ✦ Operation over a wide temperature range.
- ✦ Minimal maintenance.
- ✦ Long shelf life.
- ✦ Quick charging.

Built in Reliability

In the Pocket Plate Design, the Active materials are encapsulated between folded steel strips which are perforated from both sides. This double perforation method increases the effective surface area by 30% and helps in better utilization of the active material thereby making the battery more efficient. The folded steel strips are pressed into a frame; the alkaline electrolyte reacts only with the Active Materials and not with the steel structure, so there is no chance of internal mechanical failure. This makes the battery strong enough to withstand **s h o c k o r v i b r a t i o n .**

The pocket plate group separators are made of a wear resistant polypropylene / ABS material which is chemically inert. These cells are available in containers of polypropylene. The polypropylene container can withstand mechanical stresses, shocks and vibrations. It performs in temperature extremes without losing strength, insulates well, resists corrosion. Furthermore, the translucent nature of polypropylene allows visual check of electrolyte level for ease of maintenance. The cells are also available in Structural Foam molded, Stainless Steel containers for special requirements.

The above design features make these batteries rugged and highly reliable.

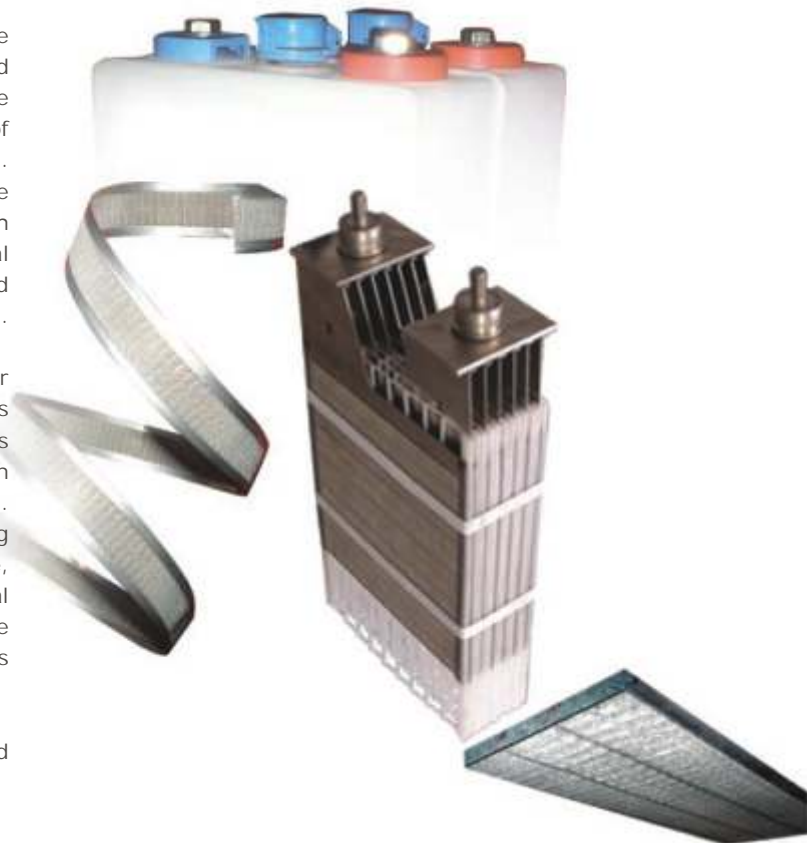

Governing Standards

HBL's NCPP batteries conform to relevant international standards such as IEC, DIN, BS, KS, etc. The Batteries are tested and certified by INTERTEK ETL SEMKO for IEC 60623 standards.

Battery Characteristics

Nickel Cadmium pocket plate batteries are the most reliable and rugged batteries available today. They can withstand to a great extent any type of abuse like overcharge, deep discharge, even accidental reverse charge and can be stored in any state of charge.

Charging

These batteries can be charged by all normal methods (like taper, constant current, constant voltage, float or trickle charging). A Dual mode charger which will recharge a discharged battery in Boost mode (higher voltage and current) and then bring it to Float mode (lower voltage) to keep it in fully charged condition is ideal to get the best performance.

Current limit - max. $0.2C_5$ A

Float voltage - 1.40 to 1.42 V/Cell

However, if single mode charger is already available, like in old systems or in locomotives, the battery can be operated with constant voltage charging.

Recommended Charging voltage setting: 1.45 to 1.50V / Cell.

Discharge Performance

The rated capacity of a Nickel Cadmium battery is defined as the Ampere Hours available at 5 hour rate of discharge to an end voltage of 1.00V/Cell at 20°C after charging at constant current of $0.2C_5$ rate for 8 hours. The nominal voltage of a single cell is 1.2 volts.

The discharge performance depends on the battery type. For example, a H type cell at 15 minutes discharge can deliver about twice the discharge current compared to an L type cell of equal rated capacity.

Always use the discharge performance tables to find the proper H, M and L type alternatives for a specific application.

The tabulated discharge performance data are valid for cells fully charged. Discharge performance data after long term float with Constant Voltage is also provided.

If the actual conditions differ from standard, the expected performance will be different. Our application engineering department will provide the details and further help you in selecting the optimum battery type for your requirement.

In accordance with its policy of continuous improvement the company reserves the right to change specifications and designs without notice. Illustrations, data, dimensions and weights given in this brochure are for guidance only.

H Range

Cell dimensions

Cell Type	Capacity at the 5 hr rate (Ah)	Cell Dimensions in mm					Cell connection bolt size	Container size reference	Reserve electrolyte cc/cell	Approx Weight (Kg) 1.2 V Block
		Height	Width	Length						
				1.2 V L (1)	2.4 V L (2)	3.6 V L (3)				
KBH 9 P	9	264	123		69	100	M8	B21-1	90	1.1
KBH 13 P	13	264	123		79	115	M8	B22-1	110	1.5
KBH 17 P	17	264	123		79	115	M8	B22-1	110	1.9
KBH 20 P	20	264	123		103	151	M8	B23-1	145	2.6
KBH 28 P	28	264	123		127	187	M8	B24-1	185	3.3
KBH 34 P	34	264	123		127	187	M8	B24-1	185	3.8
KBH 40 P	40	405	195		79	115	M10	B45-1	280	4.8
KBH 50 P	50	405	195		79	115	M10	B45-1	280	5.4
KBH 54 P	54	349	195		103	151	M10	B33-1	380	5.5
KBH 59 P	59	349	195		103	151	M10	B33-1	380	5.6
KBH 64 P	64	349	195		127	187	M10	B32-1	515	6.0
KBH 69 P	69	349	195		127	187	M10	B32-1	515	6.2
KBH 79 P	79	349	195		127	187	M10	B32-1	515	6.8
KBH 88 P	88	349	195		159	232	M10	B31B-1	650	7.8
KBH 98 P	98	349	195		159	232	M10	B31B-1	650	8.4
KBH 103 P	103	349	195		159	232	M10	B31B-1	650	9.4
KBH 110 P	110	349	195		183	268	M10	B31-1	745	9.5
KBH 118 P	118	349	195		183	268	M10	B31-1	745	9.6
KBH 127 P	127	349	195	132	252	372	2 x M10	B32-2	1030	11.0
KBH 137 P	137	349	195	132	252	372	2 x M10	B32-2	1030	12.0
KBH 140 P	140	349	195	132	252	372	2 x M10	B32-2	1030	12.3
KBH 157 P	157	349	195	132	252	372	2 x M10	B32-2	1030	13.4
KBH 170 P	170	349	195	132	252	372	2 x M10	B32-2	1030	14.5
KBH 177 P	177	349	195	159			2 x M10	B31B-2	1300	15.6
KBH 185 P	185	349	195	159			2 x M10	B31B-2	1300	16.1
KBH 196 P	196	349	195	159			2 x M10	B31B-2	1300	16.8
KBH 206 P	206	349	195	159			2 x M10	B31B-2	1300	17.4
KBH 218 P	218	349	195	183			2 x M10	B31-2	1490	18.6
KBH 236 P	236	349	195	183			2 x M10	B31-2	1490	19.6
KBH 245 P	245	349	195	183			2 x M10	B31-2	1490	20.0
KBH 265 P	265	349	195	232			3 x M10	B31B-3	1950	23.4
KBH 275 P	275	349	195	232			3 x M10	B31B-3	1950	24.0
KBH 294 P	294	349	195	232			3 x M10	B31B-3	1950	25.2
KBH 310 P	310	349	195	232			3 x M10	B31B-3	1950	26.0
KBH 330 P	330	349	195	268			3 x M10	B31-3	2235	26.7
KBH 353 P	353	349	195	268			3 x M10	B31-3	2235	28.0
KBH 362 P	362	349	195	268			3 x M10	B31-3	2235	28.9
KBH 393 P	393	349	195	304			4 x M10	B31B-4	2600	33.6
KBH 410 P	410	349	195	304			4 x M10	B31B-4	2600	34.0
KBH 420 P	420	349	195	352			4 x M10	B31-4	2980	36.0
KBH 445 P	445	349	195	352			4 x M10	B31-4	2980	36.8
KBH 471 P	471	349	195	352			4 x M10	B31-4	2980	38.0
KBH 481 P	481	349	195	352			4 x M10	B31-4	2980	38.5
KBH 491 P	491	349	195	377			5 x M10	B31B-5	3250	41.8
KBH 515 P	515	349	195	377			5 x M10	B31B-5	3250	43.0
KBH 530 P	530	349	195	437			5 x M10	B31-5	3725	47.0
KBH 545 P	545	349	195	437			5 x M10	B31-5	3725	47.5
KBH 570 P	570	349	195	437			5 x M10	B31-5	3725	48.0
KBH 590 P	590	349	195	437			5 x M10	B31-5	3725	48.5
KBH 615 P	615	405	195	377			5 x M10	B41B-5	3250	49.8
KBH 640 P	640	405	195	377			5 x M10	B41B-5	3250	51.0
KBH 670 P	670	405	195	377			5 x M10	B41B-5	3250	52.5
KBH 695 P	695	405	195	437			5 x M10	B41-5	3725	54.8
KBH 705 P	705	405	195	437			5 x M10	B41-5	3725	55.2
KBH 725 P	725	405	195	437			5 x M10	B41-5	3725	56.3
KBH 765 P	765	405	195	437			5 x M10	B41-5	3725	58.5
KBH 805 P	805	405	195	522			6 x M10	B41-6	4470	64.0
KBH 840 P	840	405	195	522			6 x M10	B41-6	4470	65.5
KBH 860 P	860	405	195	522			6 x M10	B41-6	4470	66.5
KBH 890 P	890	405	195	522			6 x M10	B41-6	4470	67.7
KBH 920 P	920	405	195	522			6 x M10	B41-6	4470	69.3
KBH 930 P	930	405	195	522			6 x M10	B41-6	4470	69.5

- ✓ Block types starting from KBH 88 P shall have handles.
- ✓ Cell ranges other than listed above can be supplied on request. The Parameters and performance will proportionately change.

Cell Performance H range

Performance fully charged with constant current charging

Final Voltage: 1.14 V/cell

Available amperes at +20° C ± 5° C

Cell Type	C _g Ah	Hours						Minutes					Seconds			
		8	5	3	2	1.5	1	30	20	15	10	5	60	30	5	1
KBH 9 P	9	1.07	1.67	2.72	3.99	5.16	7.29	10.9	13.3	15.0	17.6	22.3	35.1	40.7	50.8	53.3
KBH 13 P	13	1.55	2.41	3.93	5.76	7.45	10.5	15.7	19.2	21.7	25.4	32.2	50.7	58.8	73.3	77.0
KBH 17 P	17	2.02	3.15	5.14	7.53	9.74	13.8	20.6	25.1	28.4	33.3	42.2	66.3	76.9	95.9	101
KBH 20 P	20	2.38	3.71	6.05	8.86	11.5	16.2	24.2	29.6	33.4	39.1	49.6	78.0	90.5	113	118
KBH 28 P	28	3.33	5.19	8.47	12.4	16.0	22.7	33.9	41.4	46.7	54.8	69.4	109	127	158	166
KBH 34 P	34	4.05	6.31	10.3	15.1	19.5	27.5	41.1	50.2	56.8	66.5	84.3	133	154	192	201
KBH 40 P	40	4.76	7.56	12.2	17.7	22.9	32.0	47.1	57.4	64.4	74.5	94.2	142	163	192	198
KBH 50 P	50	5.95	9.45	15.2	22.1	28.6	40.0	58.9	71.8	80.5	93.1	118	178	204	240	248
KBH 54 P	54	6.43	10.2	16.5	23.9	30.9	43.7	65.3	79.9	90.2	106	134	211	244	305	320
KBH 59 P	59	7.02	11.2	18.0	26.2	33.8	47.8	71.4	87.3	98.5	115	146	230	267	333	350
KBH 64 P	64	7.62	12.1	19.5	28.4	36.6	51.8	77.4	94.7	107	125	159	250	290	361	379
KBH 69 P	69	8.21	13.0	21.0	30.6	39.5	55.9	83.5	102	115	135	171	269	312	389	409
KBH 79 P	79	9.40	14.9	24.1	35.0	45.3	64.0	95.6	117	132	155	196	308	357	446	468
KBH 88 P	88	10.5	16.6	26.8	39.0	50.4	71.3	107	130	147	172	218	343	398	496	521
KBH 98 P	98	11.7	18.5	29.9	43.5	56.2	79.4	119	145	164	192	243	382	443	553	581
KBH 103 P	103	12.3	19.5	31.4	45.7	59.0	83.4	125	152	172	202	255	402	466	581	610
KBH 110 P	110	13.1	20.8	33.5	48.8	63.0	89.1	133	163	184	215	273	429	498	620	652
KBH 118 P	118	14.0	22.3	36.0	52.3	67.6	95.6	143	175	197	231	293	460	534	666	699
KBH 127 P	127	15.1	24.0	38.7	56.3	72.7	103	154	188	212	249	315	495	575	716	752
KBH 137 P	137	16.3	25.9	41.8	60.8	78.4	111	166	203	229	268	340	534	620	773	812
KBH 140 P	140	16.7	26.5	42.7	62.1	80.2	113	169	207	234	274	347	546	633	790	829
KBH 157 P	157	18.7	29.7	47.9	69.6	89.9	127	190	232	262	307	389	612	710	886	930
KBH 170 P	170	20.2	32.1	51.8	75.4	97.3	138	206	251	284	333	421	663	769	959	1007
KBH 177 P	177	21.1	33.5	54.0	78.5	101	143	214	262	295	346	439	690	801	998	1049
KBH 185 P	185	22.0	35.0	56.4	82.0	106	150	224	274	309	362	458	722	837	1043	1096
KBH 196 P	196	23.3	37.0	59.8	86.9	112	159	237	290	327	384	486	764	887	1105	1161
KBH 206 P	206	24.5	38.9	62.8	91.4	118	167	249	305	344	403	510	803	932	1162	1220
KBH 218 P	218	25.9	41.2	66.5	96.7	125	177	264	322	364	427	540	850	986	1230	1291
KBH 236 P	236	28.1	44.6	72.0	105	135	191	286	349	394	462	585	920	1068	1331	1398
KBH 245 P	245	29.2	46.3	74.7	109	140	198	296	362	409	479	607	956	1109	1382	1451
KBH 265 P	265	31.5	50.1	80.8	118	152	215	321	392	442	519	657	1034	1199	1495	1570
KBH 275 P	275	32.7	52.0	83.9	122	157	223	333	407	459	538	681	1073	1244	1551	1629
KBH 294 P	294	35.0	55.6	89.7	130	168	238	356	435	491	575	729	1147	1330	1658	1742
KBH 310 P	310	36.9	58.6	94.5	137	177	251	375	459	518	607	768	1209	1403	1748	1836
KBH 330 P	330	39.3	62.4	101	146	189	267	399	488	551	646	818	1287	1493	1861	1955
KBH 353 P	353	42.0	66.7	108	157	202	286	427	522	589	691	875	1377	1597	1991	2091
KBH 362 P	362	43.1	68.4	110	161	207	293	438	536	604	708	897	1412	1638	2042	2145
KBH 393 P	393	46.8	74.3	120	174	225	318	476	581	656	769	975	1533	1778	2217	2328
KBH 410 P	410	48.8	77.5	125	182	235	332	496	607	684	802	1016	1599	1855	2312	2429
KBH 420 P	420	50.0	79.4	128	186	240	340	508	621	701	822	1041	1638	1900	2369	2488
KBH 445 P	445	53.0	84.1	136	197	255	360	538	658	743	871	1103	1736	2014	2510	2636
KBH 471 P	471	56.0	89.0	144	209	270	382	570	697	786	922	1168	1837	2131	2657	2790
KBH 481 P	481	57.2	90.9	147	213	275	390	582	712	803	941	1192	1876	2176	2713	2850
KBH 491 P	491	58.4	92.8	150	218	281	398	594	726	820	961	1218	1915	2222	2769	2909
KBH 515 P	515	61.3	97.3	157	228	295	417	623	762	860	1008	1276	2009	2330	2905	3051
KBH 530 P	530	63.1	100	162	235	303	429	641	784	885	1037	1313	2067	2398	2989	3140
KBH 545 P	545	64.9	103	166	242	312	441	659	806	910	1067	1350	2126	2466	3074	3229
KBH 570 P	570	67.8	108	174	253	326	462	690	843	952	1115	1412	2223	2579	3215	3377
KBH 590 P	590	70.2	112	180	262	338	478	714	873	985	1155	1463	2301	2670	3328	3495
KBH 615 P	615	73.2	116	188	272	352	492	724	883	990	1146	1448	2184	2496	2948	3051
KBH 640 P	640	76.2	121	195	283	366	512	757	919	1030	1192	1507	2273	2606	3068	3175
KBH 670 P	670	79.7	127	204	296	383	536	793	962	1078	1248	1578	2380	2728	3212	3323
KBH 695 P	695	82.7	131	212	307	398	556	822	998	1118	1295	1636	2468	2830	3332	3447
KBH 705 P	705	83.9	133	215	312	403	564	834	1012	1134	1313	1660	2504	2871	3380	3497
KBH 725 P	725	86.3	137	221	320	415	580	858	1041	1167	1351	1707	2575	2952	3476	3596
KBH 765 P	765	91.0	145	233	338	438	612	905	1098	1231	1425	1801	2717	3115	3667	3795
KBH 805 P	805	95.8	152	246	356	460	644	953	1156	1295	1500	1895	2859	3278	3859	3993
KBH 840 P	840	100	159	256	371	480	672	994	1206	1352	1565	1978	2983	3420	4027	4167
KBH 860 P	860	102	163	262	380	492	688	1018	1235	1384	1602	2025	3054	3502	4123	4266
KBH 890 P	890	106	168	271	393	509	712	1053	1278	1433	1658	2097	3161	3624	4267	4415
KBH 920 P	920	109	174	281	407	526	736	1089	1321	1481	1714	2167	3267	3746	4410	4563
KBH 930 P	930	111	176	284	411	532	744	1101	1335	1496	1732	2191	3303	3787	4458	4613

Cell Performance H range

Performance fully charged with constant current charging

Final Voltage: 1.10 V/cell

Available amperes at +20° C ± 5° C

Cell Type	C ₅ Ah	Hours						Minutes					Seconds			
		8	5	3	2	1.5	1	30	20	15	10	5	60	30	5	1
KBH 9 P	9	1.11	1.73	2.83	4.16	5.45	7.83	13.0	15.9	18.1	21.3	26.7	40.9	47.5	58.1	61.9
KBH 13 P	13	1.60	2.50	4.09	6.01	7.87	11.3	18.8	23.0	26.1	30.7	38.6	59.1	68.6	84.0	89.3
KBH 17 P	17	2.09	3.26	5.35	7.86	10.3	14.8	24.6	30.0	34.2	40.2	50.5	77.3	89.7	110	117
KBH 20 P	20	2.46	3.84	6.29	9.25	12.1	17.4	29.0	35.3	40.2	47.3	59.4	91.0	106	129	138
KBH 28 P	28	3.44	5.38	8.81	12.9	17.0	24.3	40.6	49.4	56.3	66.2	83.2	127	148	181	192
KBH 34 P	34	4.18	6.53	10.7	15.7	20.6	29.6	49.3	60.0	68.3	80.4	101	155	179	220	234
KBH 40 P	40	4.92	7.80	12.8	18.5	24.2	34.8	57.1	68.6	78.0	90.6	111	166	189	225	237
KBH 50 P	50	6.15	9.75	16.0	23.1	30.2	43.5	71.4	85.8	97.5	113	139	208	237	282	296
KBH 54 P	54	6.64	10.5	17.3	25.0	32.7	47.0	78.2	95.6	109	128	160	246	285	349	371
KBH 59 P	59	7.26	11.5	18.9	27.3	35.7	51.3	85.5	104	119	139	175	269	311	381	405
KBH 64 P	64	7.87	12.5	20.5	29.6	38.8	55.6	92.7	113	129	151	190	291	338	413	440
KBH 69 P	69	8.49	13.5	22.1	31.9	41.8	60.0	100	122	139	163	205	314	364	445	474
KBH 79 P	79	9.72	15.4	25.3	36.5	47.8	68.7	114	140	160	187	235	360	417	510	543
KBH 88 P	88	10.8	17.2	28.2	40.7	53.3	76.5	128	156	178	208	261	401	464	568	605
KBH 98 P	98	12.1	19.1	31.4	45.3	59.4	85.2	142	174	198	232	291	446	517	632	674
KBH 103 P	103	12.7	20.1	33.0	47.6	62.4	89.6	149	182	209	243	306	469	543	665	708
KBH 110 P	110	13.5	21.5	35.2	50.9	66.6	95.6	159	195	223	260	327	501	580	710	756
KBH 118 P	118	14.5	23.0	37.8	54.6	71.5	103	171	209	239	279	350	537	622	761	811
KBH 127 P	127	15.6	24.8	40.6	58.7	76.9	110	184	225	257	300	377	578	670	819	873
KBH 137 P	137	16.9	26.7	43.8	63.4	83.0	119	199	243	277	324	407	624	723	884	942
KBH 140 P	140	17.2	27.3	44.8	64.7	84.8	122	203	248	283	331	416	637	738	903	962
KBH 157 P	157	19.3	30.6	50.2	72.6	95.1	137	228	278	318	371	466	715	828	1013	1079
KBH 170 P	170	20.9	33.2	54.4	78.6	103	148	246	301	344	402	505	774	897	1097	1168
KBH 177 P	177	21.8	34.5	56.6	81.9	107	154	256	313	358	418	526	806	934	1142	1216
KBH 185 P	185	22.8	36.1	59.2	85.6	112	161	268	328	374	437	549	842	976	1194	1271
KBH 196 P	196	24.1	38.2	62.7	90.6	119	170	284	347	397	463	582	892	1034	1265	1347
KBH 206 P	206	25.3	40.2	65.9	95.3	125	179	299	365	417	487	612	938	1086	1329	1416
KBH 218 P	218	26.8	42.5	69.8	101	132	190	316	386	441	515	647	993	1150	1406	1498
KBH 236 P	236	29.0	46.0	75.5	109	143	205	342	418	478	558	701	1074	1245	1523	1622
KBH 245 P	245	30.1	47.8	78.4	113	148	213	355	434	496	579	728	1115	1292	1581	1684
KBH 265 P	265	32.6	51.7	84.8	123	161	230	384	469	536	626	787	1207	1398	1710	1821
KBH 275 P	275	33.8	53.6	88.0	127	167	239	398	487	557	650	817	1252	1450	1774	1890
KBH 294 P	294	36.2	57.3	94.1	136	178	256	426	521	595	695	873	1339	1551	1897	2021
KBH 310 P	310	38.1	60.5	99.2	143	188	270	449	549	628	733	921	1411	1635	2000	2131
KBH 330 P	330	40.6	64.4	106	153	200	287	478	584	668	780	980	1502	1741	2129	2268
KBH 353 P	353	43.4	68.8	113	163	214	307	512	625	715	835	1048	1607	1862	2277	2426
KBH 362 P	362	44.5	70.6	116	167	219	315	525	641	733	856	1075	1648	1909	2335	2488
KBH 393 P	393	48.3	76.6	126	182	238	342	569	696	796	929	1167	1789	2073	2535	2701
KBH 410 P	410	50.4	80.0	131	190	248	356	594	726	830	969	1218	1867	2162	2645	2818
KBH 420 P	420	51.7	81.9	134	194	254	365	609	744	850	993	1247	1912	2215	2710	2887
KBH 445 P	445	54.7	86.8	142	206	270	387	645	788	901	1052	1322	2026	2347	2871	3058
KBH 471 P	471	57.9	91.8	151	218	285	410	683	834	953	1113	1399	2144	2484	3039	3237
KBH 481 P	481	59.2	93.8	154	222	291	418	697	852	974	1137	1429	2190	2537	3103	3306
KBH 491 P	491	60.4	95.7	157	227	297	427	711	870	994	1161	1458	2235	2590	3168	3375
KBH 515 P	515	63.3	100	165	238	312	448	746	912	1043	1217	1530	2345	2716	3323	3540
KBH 530 P	530	65.2	103	170	245	321	461	768	939	1073	1253	1574	2413	2795	3419	3643
KBH 545 P	545	67.0	106	174	252	330	474	790	965	1103	1288	1619	2481	2874	3516	3746
KBH 570 P	570	70.1	111	182	264	345	496	826	1010	1154	1348	1693	2595	3006	3677	3918
KBH 590 P	590	72.6	115	189	273	357	513	855	1045	1194	1395	1752	2686	3112	3806	4055
KBH 615 P	615	75.6	120	197	284	372	535	874	1055	1200	1393	1712	2559	2911	3467	3641
KBH 640 P	640	78.7	125	205	296	387	556	914	1098	1249	1450	1782	2663	3030	3608	3789
KBH 670 P	670	82.4	131	214	310	405	583	957	1149	1307	1518	1865	2788	3172	3777	3967
KBH 695 P	695	85.5	136	222	321	420	604	993	1192	1356	1574	1935	2892	3290	3918	4115
KBH 705 P	705	86.7	137	226	326	427	613	1007	1209	1375	1597	1963	2934	3337	3974	4174
KBH 725 P	725	89.2	141	232	335	439	630	1036	1244	1414	1642	2018	3017	3432	4087	4292
KBH 765 P	765	94.1	149	245	354	463	665	1093	1312	1492	1733	2130	3184	3621	4312	4530
KBH 805 P	805	99.0	157	258	372	487	700	1150	1381	1570	1823	2241	3350	3811	4538	4766
KBH 840 P	840	103	164	269	388	508	730	1200	1441	1639	1903	2339	3496	3976	4735	4973
KBH 860 P	860	106	168	275	398	520	748	1229	1475	1678	1948	2394	3579	4071	4848	5093
KBH 890 P	890	109	174	285	412	538	774	1271	1527	1736	2016	2478	3704	4213	5017	5269
KBH 920 P	920	113	179	294	425	557	800	1314	1578	1795	2084	2561	3829	4355	5186	5447
KBH 930 P	930	114	181	298	430	563	809	1329	1595	1814	2106	2589	3870	4402	5242	5506

Cell Performance H range

Performance fully charged with constant current charging

Final Voltage: 1.05 V/cell

Available amperes at +20° C ± 5° C

Cell Type	C ₅ Ah	Hours						Minutes					Seconds			
		8	5	3	2	1.5	1	30	20	15	10	5	60	30	5	1
KBH 9 P	9	1.12	1.77	2.92	4.32	5.66	8.19	14.6	19.0	21.5	25.4	32.0	48.8	55.4	68.5	73.7
KBH 13 P	13	1.62	2.56	4.22	6.24	8.18	11.8	21.1	27.5	31.1	36.7	46.2	70.5	80.0	98.9	107
KBH 17 P	17	2.12	3.35	5.52	8.16	10.7	15.5	27.6	36.0	40.7	48.0	60.4	92.1	105	129	139
KBH 20 P	20	2.49	3.94	6.49	9.60	12.6	18.2	32.5	42.3	47.8	56.5	71.0	108	123	152	164
KBH 28 P	28	3.49	5.52	9.09	13.4	17.6	25.5	45.4	59.2	67.0	79.1	99	152	172	213	229
KBH 34 P	34	4.23	6.70	11.0	16.3	21.4	30.9	55.2	71.9	81.3	96.1	121	184	209	259	278
KBH 40 P	40	4.98	7.88	13.0	19.2	25.1	36.4	64.7	82.8	92.9	109	134	196	221	267	278
KBH 50 P	50	6.23	9.85	16.2	24.0	31.4	45.5	80.9	104	116	136	168	245	276	333	348
KBH 54 P	54	6.72	10.6	17.5	25.9	34.0	49.1	88.4	114	129	153	192	293	333	412	442
KBH 59 P	59	7.35	11.6	19.2	28.3	37.1	53.7	96.6	125	141	167	210	320	364	450	483
KBH 64 P	64	7.97	12.6	20.8	30.7	40.3	58.2	105	135	153	181	227	347	394	488	524
KBH 69 P	69	8.59	13.6	22.4	33.1	43.4	62.8	113	146	165	195	245	374	426	526	565
KBH 79 P	79	9.84	15.6	25.6	37.9	49.7	71.9	129	167	189	223	281	428	488	602	647
KBH 88 P	88	11.0	17.3	28.6	42.2	55.4	80.1	144	186	210	249	313	477	543	671	721
KBH 98 P	98	12.2	19.3	31.8	47.0	61.6	89.2	160	207	234	277	348	531	605	747	803
KBH 103 P	103	12.8	20.3	33.4	49.4	64.8	93.7	169	218	246	291	366	558	636	784	844
KBH 110 P	110	13.7	21.7	35.7	52.8	69.2	100	180	233	263	311	391	596	679	837	901
KBH 118 P	118	14.7	23.3	38.3	56.6	74.2	107	192	250	282	334	419	640	728	899	966
KBH 127 P	127	15.8	25.0	41.2	61.0	79.9	116	208	269	304	359	451	688	784	967	1040
KBH 137 P	137	17.1	27.0	44.5	65.8	86.2	125	223	290	328	387	487	743	846	1044	1122
KBH 140 P	140	17.4	27.6	45.4	67.2	88.1	127	229	296	335	396	497	759	864	1065	1147
KBH 157 P	157	19.5	30.9	51.0	75.4	98.8	143	256	332	375	444	558	851	969	1196	1286
KBH 170 P	170	21.2	33.5	55.2	81.6	107	155	278	360	407	480	604	921	1049	1294	1392
KBH 177 P	177	22.0	34.9	57.5	85.0	111	161	289	375	423	500	629	959	1093	1349	1450
KBH 185 P	185	23.0	36.5	60.1	88.8	116	168	303	391	442	523	657	1003	1142	1410	1515
KBH 196 P	196	24.4	38.6	63.6	94.1	123	178	320	415	469	554	697	1062	1210	1494	1605
KBH 206 P	206	25.6	40.6	66.9	98.9	130	187	337	436	493	582	732	1117	1272	1570	1687
KBH 218 P	218	27.1	43.0	70.8	105	137	198	357	461	521	616	774	1182	1346	1662	1785
KBH 236 P	236	29.4	46.5	76.6	113	148	215	385	499	564	667	839	1279	1457	1799	1933
KBH 245 P	245	30.5	48.3	79.5	118	154	223	401	518	586	692	870	1328	1512	1867	2007
KBH 265 P	265	33.0	52.2	86.0	127	167	241	432	561	634	749	942	1436	1636	2020	2170
KBH 275 P	275	34.2	54.2	89.3	132	173	250	450	582	658	777	977	1491	1698	2096	2252
KBH 294 P	294	36.6	57.9	95.4	141	185	268	479	622	703	831	1045	1593	1815	2241	2408
KBH 310 P	310	38.6	61.1	101	149	195	282	508	656	741	876	1101	1680	1914	2363	2539
KBH 330 P	330	41.1	65.0	107	158	208	300	540	698	789	933	1172	1789	2037	2515	2703
KBH 353 P	353	43.9	69.6	115	169	222	321	576	747	844	998	1255	1913	2179	2691	2891
KBH 362 P	362	45.1	71.3	118	174	228	329	593	766	866	1023	1286	1962	2235	2759	2965
KBH 393 P	393	48.9	77.5	128	189	247	358	641	832	940	1111	1397	2130	2426	2995	3219
KBH 410 P	410	51.0	80.8	133	197	258	373	671	868	980	1159	1456	2222	2531	3125	3358
KBH 420 P	420	52.3	82.8	136	202	264	382	688	889	1004	1187	1491	2276	2593	3201	3440
KBH 445 P	445	55.4	87.7	144	214	280	405	729	942	1064	1258	1580	2412	2747	3392	3645
KBH 471 P	471	58.6	92.8	153	226	296	429	768	997	1126	1331	1674	2553	2907	3590	3857
KBH 481 P	481	59.9	94.8	156	231	303	438	788	1018	1150	1360	1708	2607	2969	3666	3939
KBH 491 P	491	61.1	96.8	159	236	309	447	801	1039	1174	1388	1745	2661	3031	3742	4021
KBH 515 P	515	64.1	102	167	247	324	469	843	1090	1231	1456	1829	2791	3179	3925	4218
KBH 530 P	530	66.0	104	172	254	333	482	868	1121	1267	1498	1882	2873	3272	4040	4341
KBH 545 P	545	67.9	107	177	262	343	496	893	1153	1303	1540	1935	2954	3364	4154	4464
KBH 570 P	570	71.0	112	185	274	359	519	934	1206	1363	1611	2024	3089	3519	4345	4668
KBH 590 P	590	73.5	116	192	283	371	537	962	1248	1411	1668	2095	3198	3642	4497	4832
KBH 615 P	615	76.6	121	200	295	387	559	995	1266	1429	1671	2068	3015	3400	4102	4280
KBH 640 P	640	79.7	126	208	307	402	582	1035	1325	1487	1739	2152	3137	3538	4268	4454
KBH 670 P	670	83.4	132	217	322	421	609	1083	1387	1556	1821	2253	3284	3704	4468	4662
KBH 695 P	695	86.5	137	226	334	437	632	1124	1439	1614	1889	2337	3407	3842	4635	4836
KBH 705 P	705	87.8	139	229	338	443	641	1140	1460	1638	1916	2371	3456	3898	4702	4906
KBH 725 P	725	90.3	143	235	348	456	659	1172	1501	1684	1970	2438	3554	4008	4835	5045
KBH 765 P	765	95.2	151	248	367	481	695	1237	1584	1777	2079	2572	3750	4229	5102	5324
KBH 805 P	805	100	159	261	386	506	732	1302	1667	1870	2188	2707	3946	4450	5369	5602
KBH 840 P	840	105	166	273	403	528	764	1358	1739	1951	2283	2824	4118	4643	5602	5846
KBH 860 P	860	107	170	279	413	541	782	1391	1781	1998	2337	2892	4216	4754	5736	5985
KBH 890 P	890	111	175	289	427	559	809	1439	1843	2067	2418	2993	4363	4920	5936	6193
KBH 920 P	920	115	181	299	442	578	836	1488	1905	2137	2500	3093	4510	5086	6136	6402
KBH 930 P	930	116	183	302	446	585	845	1504	1925	2160	2527	3127	4559	5141	6202	6472

Cell Performance H range

Performance fully charged with constant current charging

Final Voltage: 1.00 V/cell

Available amperes at +20° C ± 5° C

Cell Type	C ₅ Ah	Hours						Minutes					Seconds			
		8	5	3	2	1.5	1	30	20	15	10	5	60	30	5	1
KBH 9 P	9	1.14	1.80	2.96	4.40	5.79	8.47	15.5	20.9	24.5	29.1	37.0	55.3	63.1	79.4	87.1
KBH 13 P	13	1.64	2.60	4.28	6.35	8.36	12.2	22.4	30.1	35.4	42.0	53.5	79.9	91.2	115	126
KBH 17 P	17	2.15	3.40	5.59	8.30	10.9	16.0	29.3	39.4	46.3	54.9	70.0	105	119	150	165
KBH 20 P	20	2.52	4.00	6.58	9.77	12.9	18.8	34.5	46.4	54.5	64.6	82.3	123	140	177	194
KBH 28 P	28	3.53	5.60	9.21	13.7	18.0	26.3	48.3	64.9	76.3	90.5	115	172	196	247	271
KBH 34 P	34	4.29	6.80	11.2	16.6	21.9	32.0	58.6	78.8	92.6	110	140	209	238	300	329
KBH 40 P	40	5.05	8.00	13.2	19.5	25.7	37.6	68.2	91.8	106	125	156	225	254	309	329
KBH 50 P	50	6.31	10.00	16.5	24.4	32.1	47.0	85.3	115	133	156	195	281	318	386	411
KBH 54 P	54	6.82	10.8	17.8	26.4	34.7	50.8	93.1	125	147	175	222	332	379	477	523
KBH 59 P	59	7.45	11.8	19.5	28.8	38.0	55.5	102	137	161	191	243	363	414	521	571
KBH 64 P	64	8.08	12.8	21.1	31.3	41.2	60.2	110	148	174	207	263	393	449	565	620
KBH 69 P	69	8.71	13.8	22.8	33.7	44.4	64.9	119	160	188	223	284	424	484	609	668
KBH 79 P	79	9.97	15.8	26.1	38.6	50.8	74.3	136	183	215	255	325	486	554	697	765
KBH 88 P	88	11.1	17.6	29.1	43.0	56.6	82.8	152	204	240	284	362	541	617	777	852
KBH 98 P	98	12.4	19.6	32.4	47.9	63.1	92.2	169	227	267	317	403	602	687	865	949
KBH 103 P	103	13.0	20.6	34.0	50.3	66.3	96.9	178	239	281	333	424	633	722	909	997
KBH 110 P	110	13.9	22.0	36.3	53.7	70.8	103	190	255	300	356	453	676	771	971	1065
KBH 118 P	118	14.9	23.6	39.0	57.6	75.9	111	204	274	322	381	486	725	827	1041	1142
KBH 127 P	127	16.0	25.4	41.9	62.0	81.7	119	219	294	346	410	523	781	891	1121	1229
KBH 137 P	137	17.3	27.4	45.2	66.9	88.2	129	236	318	373	443	564	842	961	1209	1326
KBH 140 P	140	17.7	28.0	46.2	68.4	90.1	132	241	325	381	452	576	860	982	1236	1355
KBH 157 P	157	19.8	31.4	51.8	76.7	101	148	271	364	428	507	646	965	1101	1386	1520
KBH 170 P	170	21.5	34.0	56.1	83.0	109	160	293	394	463	549	700	1045	1192	1500	1646
KBH 177 P	177	22.3	35.4	58.4	86.4	114	166	305	411	482	572	729	1088	1241	1562	1713
KBH 185 P	185	23.4	37.0	61.1	90.4	119	174	319	429	504	598	761	1137	1297	1633	1791
KBH 196 P	196	24.7	39.2	64.7	95.7	126	184	338	455	534	633	807	1205	1374	1730	1897
KBH 206 P	206	26.0	41.2	68.0	101	133	194	355	478	561	666	848	1266	1445	1818	1994
KBH 218 P	218	27.5	43.6	72.0	106	140	205	376	505	594	705	897	1340	1529	1924	2110
KBH 236 P	236	29.8	47.2	77.9	115	152	222	407	548	643	763	972	1451	1655	2083	2285
KBH 245 P	245	30.9	49.0	80.9	120	158	230	423	568	668	792	1008	1506	1718	2162	2372
KBH 265 P	265	33.5	53.0	87.5	129	171	249	457	615	722	856	1091	1629	1858	2339	2565
KBH 275 P	275	34.7	55.0	90.8	134	177	259	474	638	749	889	1132	1690	1928	2427	2662
KBH 294 P	294	37.1	58.8	97.1	144	189	277	507	682	801	950	1210	1807	2062	2595	2846
KBH 310 P	310	39.1	62.0	102	151	199	292	535	719	845	1002	1276	1905	2174	2736	3001
KBH 330 P	330	41.7	66.0	109	161	212	310	569	765	899	1067	1358	2028	2314	2913	3195
KBH 353 P	353	44.6	70.6	117	172	227	332	609	820	962	1141	1453	2170	2475	3116	3417
KBH 362 P	362	45.7	72.4	120	177	233	340	624	839	986	1170	1490	2225	2539	3195	3504
KBH 393 P	393	49.6	78.6	130	192	253	370	678	912	1071	1270	1618	2415	2756	3469	3804
KBH 410 P	410	51.8	82.0	135	200	264	386	707	951	1117	1325	1687	2520	2875	3619	3969
KBH 420 P	420	53.0	84.0	139	205	270	395	724	974	1144	1357	1728	2581	2945	3707	4066
KBH 445 P	445	56.2	89.0	147	217	286	419	768	1032	1213	1438	1831	2735	3121	3928	4308
KBH 471 P	471	59.5	94.2	155	230	303	443	812	1093	1283	1522	1939	2895	3303	4157	4560
KBH 481 P	481	60.7	96.2	159	235	310	452	830	1115	1311	1555	1979	2956	3373	4245	4656
KBH 491 P	491	62.0	98.2	162	240	316	462	847	1139	1338	1587	2021	3018	3443	4334	4753
KBH 515 P	515	65.0	103	170	252	331	484	888	1194	1403	1665	2119	3165	3612	4545	4985
KBH 530 P	530	66.9	106	175	259	341	498	914	1229	1444	1713	2181	3258	3717	4678	5131
KBH 545 P	545	68.8	109	180	266	351	513	940	1264	1485	1761	2243	3350	3822	4810	5276
KBH 570 P	570	72.0	114	188	278	367	536	983	1322	1553	1842	2346	3503	3997	5031	5518
KBH 590 P	590	74.5	118	195	288	380	555	1018	1369	1608	1907	2430	3626	4137	5207	5712
KBH 615 P	615	77.6	123	203	300	395	578	1049	1411	1628	1917	2394	3461	3907	4753	5053
KBH 640 P	640	80.8	128	211	312	411	602	1092	1468	1699	1997	2491	3602	4066	4946	5259
KBH 670 P	670	84.6	134	221	327	430	630	1143	1537	1779	2090	2608	3770	4257	5178	5505
KBH 695 P	695	87.7	139	229	339	446	653	1186	1594	1845	2168	2705	3911	4416	5371	5711
KBH 705 P	705	89.0	141	232	344	453	663	1203	1617	1872	2200	2744	3967	4479	5448	5793
KBH 725 P	725	91.5	145	239	354	466	682	1237	1663	1925	2262	2822	4080	4606	5603	5957
KBH 765 P	765	96.6	153	252	373	491	719	1305	1755	2031	2387	2978	4305	4860	5912	6286
KBH 805 P	805	102	161	265	393	517	757	1373	1847	2138	2512	3134	4530	5114	6221	6615
KBH 840 P	840	106	168	277	410	539	790	1433	1927	2230	2621	3270	4727	5337	6491	6902
KBH 860 P	860	109	172	284	420	552	809	1467	1973	2284	2683	3348	4840	5464	6646	7067
KBH 890 P	890	112	178	293	435	572	837	1518	2042	2363	2777	3464	5008	5654	6878	7313
KBH 920 P	920	116	184	303	449	591	865	1569	2111	2443	2871	3581	5177	5845	7110	7560
KBH 930 P	930	117	186	307	454	597	874	1586	2134	2469	2902	3620	5234	5909	7187	7642

Cell Performance H range

Performance fully charged with constant current charging

Available amperes at +20° C ± 5° C Final Voltage: 0.85 V/cell

Cell Type	C ₅ Ah	Seconds				
		90	60	30	5	1
KBH 9 P	9	68.2	75.6	85.7	111	121
KBH 13 P	13	98.5	109	124	160	174
KBH 17 P	17	129	143	162	210	228
KBH 20 P	20	152	168	190	247	268
KBH 28 P	28	212	235	267	346	376
KBH 34 P	34	258	286	324	420	456
KBH 40 P	40	284	310	348	427	467
KBH 50 P	50	355	388	435	534	583
KBH 54 P	54	409	454	514	667	725
KBH 59 P	59	447	496	563	728	792
KBH 64 P	64	485	538	610	790	859
KBH 69 P	69	523	580	659	852	926
KBH 79 P	79	599	664	754	975	1060
KBH 88 P	88	667	739	840	1086	1181
KBH 98 P	98	743	824	936	1210	1315
KBH 103 P	103	780	866	981	1272	1383
KBH 110 P	110	833	924	1048	1358	1477
KBH 118 P	118	894	992	1127	1457	1584
KBH 127 P	127	962	1067	1210	1568	1705
KBH 137 P	137	1040	1151	1309	1691	1839
KBH 140 P	140	1061	1176	1333	1728	1879
KBH 157 P	157	1190	1320	1498	1938	2107
KBH 170 P	170	1288	1429	1619	2099	2282
KBH 177 P	177	1341	1490	1689	2185	2376
KBH 185 P	185	1402	1555	1762	2284	2483
KBH 196 P	196	1487	1647	1869	2420	2631
KBH 206 P	206	1561	1731	1962	2543	2765
KBH 218 P	218	1652	1832	2076	2691	2926
KBH 236 P	236	1790	1983	2251	2914	3168
KBH 245 P	245	1856	2059	2333	3025	3289
KBH 265 P	265	2010	2227	2530	3272	3557
KBH 275 P	275	2083	2311	2619	3395	3691
KBH 294 P	294	2230	2471	2808	3630	3946
KBH 310 P	310	2348	2605	2952	3827	4161
KBH 330 P	330	2500	2773	3143	4074	4430
KBH 353 P	353	2678	2966	3370	4358	4738
KBH 362 P	362	2742	3042	3448	4469	4859
KBH 393 P	393	2980	3303	3750	4852	5275
KBH 410 P	410	3106	3445	3905	5062	5503
KBH 420 P	420	3182	3529	4000	5185	5638
KBH 445 P	445	3371	3739	4238	5494	5973
KBH 471 P	471	3571	3958	4499	5815	6322
KBH 481 P	481	3644	4042	4581	5938	6456
KBH 491 P	491	3720	4126	4690	6062	6591
KBH 515 P	515	3902	4328	4905	6358	6913
KBH 530 P	530	4015	4454	5048	6543	7114
KBH 545 P	545	4129	4580	5190	6728	7315
KBH 570 P	570	4318	4790	5429	7037	7651
KBH 590 P	590	4470	4958	5630	7284	7919
KBH 615 P	615	4362	4773	5348	6571	7153
KBH 640 P	640	4540	4967	5565	6838	7442
KBH 470 P	670	4752	5200	5826	7158	7793
KBH 695 P	695	4929	5394	6043	7425	8083
KBH 705 P	705	5000	5471	6130	7532	8198
KBH 725 P	725	5142	5627	6304	7746	8432
KBH 765 P	765	5426	5937	6652	8173	8895
KBH 805 P	805	5709	6248	7000	8600	9363
KBH 840 P	840	5957	6519	7304	8974	9770
KBH 860 P	860	6099	6674	7478	9188	10002
KBH 890 P	890	6312	6907	7739	9509	10351
KBH 920 P	920	6525	7140	8000	9829	10700
KBH 930 P	930	6596	7218	8087	9936	10816

Available amperes at +20° C ± 5° C Final Voltage: 0.65 V/cell

Cell Type	C ₅ Ah	Seconds				
		90	60	30	5	1
KBH 9 P	9	88.2	98.9	112.5	145	161
KBH 13 P	13	127	143	163	210	232
KBH 17 P	17	167	187	213	274	304
KBH 20 P	20	196	220	250	323	357
KBH 28 P	28	275	308	350	452	500
KBH 34 P	34	333	374	425	548	607
KBH 40 P	40	374	412	465	580	625
KBH 50 P	50	467	515	581	725	781
KBH 54 P	54	529	593	678	871	964
KBH 59 P	59	579	648	740	953	1060
KBH 64 P	64	627	703	803	1032	1143
KBH 69 P	69	677	758	866	1113	1240
KBH 79 P	79	775	868	991	1280	1420
KBH 88 P	88	863	967	1104	1419	1581
KBH 98 P	98	961	1077	1230	1581	1761
KBH 103 P	103	1010	1132	1292	1661	1851
KBH 110 P	110	1078	1209	1380	1774	1977
KBH 118 P	118	1159	1297	1481	1909	2120
KBH 127 P	127	1245	1396	1593	2048	2282
KBH 137 P	137	1343	1505	1719	2210	2462
KBH 140 P	140	1373	1538	1757	2258	2516
KBH 157 P	157	1541	1725	1970	2540	2821
KBH 170 P	170	1667	1868	2133	2742	3055
KBH 177 P	177	1739	1945	2221	2859	3181
KBH 185 P	185	1817	2033	2321	2984	3324
KBH 196 P	196	1922	2154	2459	3166	3522
KBH 206 P	206	2020	2264	2585	3323	3702
KBH 218 P	218	2137	2396	2735	3516	3917
KBH 236 P	236	2318	2593	2961	3810	4241
KBH 245 P	245	2402	2692	3074	3952	4403
KBH 265 P	265	2601	2912	3325	4281	4762
KBH 275 P	275	2696	3022	3450	4435	4942
KBH 294 P	294	2882	3231	3689	4750	5283
KBH 310 P	310	3039	3407	3890	5008	5571
KBH 330 P	330	3235	3626	4141	5331	5930
KBH 353 P	353	3461	3879	4429	5703	6343
KBH 362 P	362	3549	3978	4542	5848	6505
KBH 393 P	393	3861	4319	4931	6349	7062
KBH 410 P	410	4020	4505	5144	6624	7367
KBH 420 P	420	4118	4615	5270	6785	7547
KBH 445 P	445	4363	4890	5583	7189	7996
KBH 471 P	471	4622	5176	5910	7609	8464
KBH 481 P	481	4716	5286	6035	7771	8643
KBH 491 P	491	4821	5396	6161	7932	8823
KBH 515 P	515	5049	5659	6462	8320	9254
KBH 530 P	530	5196	5824	6650	8562	9524
KBH 545 P	545	5343	5989	6838	8805	9793
KBH 570 P	570	5588	6264	7152	9208	10243
KBH 590 P	590	5790	6484	7403	9532	10602
KBH 615 P	615	5748	6340	7118	8913	9647
KBH 640 P	640	5981	6598	7407	9275	10039
KBH 470 P	670	6262	6907	7755	9710	10510
KBH 695 P	695	6495	7165	8044	10072	10902
KBH 705 P	705	6589	7268	8160	10217	11059
KBH 725 P	725	6776	7474	8391	10507	11373
KBH 765 P	765	7150	7887	8854	11087	12000
KBH 805 P	805	7523	8299	9317	11667	12627
KBH 840 P	840	7850	8660	9722	12174	13176
KBH 860 P	860	8037	8866	9954	12464	13490
KBH 890 P	890	8318	9175	10301	12899	13961
KBH 920 P	920	8598	9485	10648	13333	14431
KBH 930 P	930	8692	9588	10764	13478	14588

Cell Performance **H** range

Performance after long term floating with constant voltage charging

Final Voltage: 1.14V/cell

Available amperes at +20° C ± 5° C

Cell Type	C ₅ Ah	Hours						Minutes					Seconds			
		8	5	3	2	1.5	1	30	20	15	10	5	60	30	5	1
KBH 9 P	9	1.07	1.67	2.72	3.99	5.16	6.96	9.66	11.2	12.2	13.7	16.6	24.8	28.8	35.9	37.7
KBH 13 P	13	1.55	2.41	3.93	5.76	7.45	10.1	14.0	16.1	17.7	19.8	23.9	35.8	41.6	51.8	54.4
KBH 17 P	17	2.02	3.15	5.14	7.53	9.74	13.2	18.2	21.1	23.1	25.9	31.3	46.9	54.4	67.8	71.2
KBH 20 P	20	2.38	3.71	6.05	8.86	11.5	15.5	21.5	24.8	27.2	30.5	36.8	55.1	64.0	79.8	83.8
KBH 28 P	28	3.33	5.19	8.47	12.4	16.0	21.7	30.1	34.8	38.1	42.7	51.5	77.2	89.6	112	117
KBH 34 P	34	4.05	6.31	10.3	15.1	19.5	26.3	36.5	42.2	46.3	51.9	62.6	93.8	109	136	142
KBH 40 P	40	4.76	7.56	12.2	17.7	22.9	30.6	41.8	48.2	52.5	58.1	69.9	100	115	136	140
KBH 50 P	50	5.95	9.45	15.2	22.1	28.6	38.2	52.2	60.3	65.6	72.7	87.4	126	144	169	175
KBH 54 P	54	6.43	10.2	16.5	23.9	30.9	41.8	58.0	67.1	73.5	82.4	99.3	149	173	215	226
KBH 59 P	59	7.02	11.2	18.0	26.2	33.8	45.6	63.3	73.3	80.3	90.1	108	163	189	235	247
KBH 64 P	64	7.62	12.1	19.5	28.4	36.6	49.5	68.7	79.5	87.1	97.7	118	176	205	255	268
KBH 69 P	69	8.21	13.0	21.0	30.6	39.5	53.4	74.1	85.7	93.9	105	127	190	221	275	289
KBH 79 P	79	9.40	14.9	24.1	35.0	45.3	61.1	84.8	98.2	107	121	145	218	253	315	331
KBH 88 P	88	10.5	16.6	26.8	39.0	50.4	68.1	94.5	109	120	134	162	243	282	351	369
KBH 98 P	98	11.7	18.5	29.9	43.5	56.2	75.8	105	122	133	150	180	270	314	391	410
KBH 103 P	103	12.3	19.5	31.4	45.7	59.0	79.7	111	128	140	157	189	284	330	411	431
KBH 110 P	110	13.1	20.8	33.5	48.8	63.0	85.1	118	137	150	168	202	303	352	439	461
KBH 118 P	118	14.0	22.3	36.0	52.3	67.6	91.3	127	147	161	180	217	325	377	471	494
KBH 127 P	127	15.1	24.0	38.7	56.3	72.7	98.2	136	158	173	194	233	350	406	506	532
KBH 137 P	137	16.3	25.9	41.8	60.8	78.4	106	147	170	186	209	252	378	438	546	574
KBH 140 P	140	16.7	26.5	42.7	62.1	80.2	108	150	174	190	214	257	386	448	558	586
KBH 157 P	157	18.7	29.7	47.9	69.6	89.9	121	169	195	214	240	289	433	502	626	658
KBH 170 P	170	20.2	32.1	51.8	75.4	97.3	132	182	211	231	259	313	469	544	678	712
KBH 177 P	177	21.1	33.5	54.0	78.5	101	137	190	220	241	270	325	488	566	706	741
KBH 185 P	185	22.0	35.0	56.4	82.0	106	143	199	230	252	282	340	510	592	738	775
KBH 196 P	196	23.3	37.0	59.8	86.9	112	152	210	244	267	299	360	540	627	782	821
KBH 206 P	206	24.5	38.9	62.8	91.4	118	159	221	256	280	314	379	568	659	821	863
KBH 218 P	218	25.9	41.2	66.5	96.7	125	169	234	271	297	333	401	601	697	869	913
KBH 236 P	236	28.1	44.6	72.0	105	135	183	253	293	321	360	434	651	755	941	988
KBH 245 P	245	29.2	46.3	74.7	109	140	190	263	304	333	374	450	676	784	977	1026
KBH 265 P	265	31.5	50.1	80.8	118	152	205	284	329	361	405	487	731	848	1057	1110
KBH 275 P	275	32.7	52.0	83.9	122	157	213	295	342	374	420	506	758	880	1097	1152
KBH 294 P	294	35.0	55.6	89.7	130	168	227	316	365	400	449	541	811	941	1172	1231
KBH 310 P	310	36.9	58.6	94.5	137	177	240	333	385	422	473	570	855	992	1236	1298
KBH 330 P	330	39.3	62.4	101	146	189	255	354	410	449	504	607	910	1056	1316	1382
KBH 353 P	353	42.0	66.7	108	157	202	273	379	439	480	539	649	973	1129	1408	1479
KBH 362 P	362	43.1	68.4	110	161	207	280	389	450	493	553	666	998	1158	1444	1516
KBH 393 P	393	46.8	74.3	120	174	225	304	422	488	535	600	723	1084	1257	1567	1646
KBH 410 P	410	48.8	77.5	125	182	235	317	440	509	558	626	754	1131	1312	1635	1717
KBH 420 P	420	50.0	79.4	128	186	240	325	451	522	571	641	772	1158	1344	1675	1759
KBH 445 P	445	53.0	84.1	136	197	255	344	478	553	605	679	818	1227	1424	1774	1864
KBH 471 P	471	56.0	89.0	144	209	270	364	506	585	641	719	867	1299	1507	1878	1973
KBH 481 P	481	57.2	90.9	147	213	275	372	516	598	654	734	884	1326	1539	1918	2015
KBH 491 P	491	58.4	92.8	150	218	281	380	527	610	668	749	904	1354	1571	1958	2056
KBH 515 P	515	61.3	97.3	157	228	295	398	553	640	701	786	947	1420	1648	2054	2157
KBH 530 P	530	63.1	100	162	235	303	410	569	659	721	809	974	1461	1696	2113	2220
KBH 545 P	545	64.9	103	166	242	312	422	585	677	742	832	1002	1503	1744	2173	2283
KBH 570 P	570	67.8	108	174	253	326	441	612	708	776	870	1048	1572	1823	2273	2387
KBH 590 P	590	70.2	112	180	262	338	456	633	733	803	901	1086	1627	1887	2353	2471
KBH 615 P	615	73.2	116	188	272	352	470	642	742	806	894	1074	1544	1765	2084	2157
KBH 640 P	640	76.2	121	195	283	366	489	672	772	839	930	1118	1607	1842	2169	2244
KBH 670 P	670	79.7	127	204	296	383	512	703	808	879	974	1171	1682	1929	2271	2350
KBH 695 P	695	82.7	131	212	307	398	531	730	838	911	1010	1214	1745	2001	2356	2437
KBH 705 P	705	83.9	133	215	312	403	539	740	850	924	1024	1232	1770	2029	2389	2472
KBH 725 P	725	86.3	137	221	320	415	554	761	874	951	1053	1267	1820	2087	2457	2543
KBH 765 P	765	91.0	145	233	338	438	584	803	923	1003	1112	1337	1921	2202	2593	2683
KBH 805 P	805	95.8	152	246	356	460	615	845	971	1056	1170	1406	2021	2317	2728	2823
KBH 840 P	840	100	159	256	371	480	642	882	1013	1102	1221	1468	2109	2418	2847	2946
KBH 860 P	860	102	163	262	380	492	657	903	1037	1128	1250	1503	2159	2476	2915	3016
KBH 890 P	890	106	168	271	393	509	680	934	1073	1168	1293	1556	2235	2562	3016	3121
KBH 920 P	920	109	174	281	407	526	703	966	1110	1207	1337	1608	2310	2648	3118	3226
KBH 930 P	930	111	176	284	411	532	711	976	1122	1220	1351	1626	2335	2677	3152	3261

Cell Performance H range

Performance after long term floating with constant voltage charging

Final Voltage: 1.10 V/cell

Available amperes at +20° C ± 5° C

Cell Type	C _g Ah	Hours						Minutes					Seconds			
		8	5	3	2	1.5	1	30	20	15	10	5	60	30	5	1
KBH 9 P	9	1.11	1.73	2.83	4.16	5.45	7.83	12.1	14.1	15.6	17.8	21.3	30.9	35.8	43.9	46.7
KBH 13 P	13	1.60	2.50	4.09	6.01	7.87	11.3	17.4	20.3	22.5	25.7	30.7	44.7	51.8	63.4	67.5
KBH 17 P	17	2.09	3.26	5.35	7.86	10.3	14.8	22.8	26.6	29.4	33.6	40.1	58.4	67.7	82.9	88.2
KBH 20 P	20	2.46	3.84	6.29	9.25	12.1	17.4	26.8	31.3	34.6	39.5	47.2	68.7	79.6	97.5	104
KBH 28 P	28	3.44	5.38	8.81	12.9	17.0	24.3	37.5	43.8	48.4	55.3	66.1	96.2	111	137	145
KBH 34 P	34	4.18	6.53	10.7	15.7	20.6	29.6	45.6	53.1	58.8	67.1	80.3	117	135	166	176
KBH 40 P	40	4.92	7.80	12.8	18.5	24.2	34.8	52.9	60.7	67.1	75.7	88.5	126	143	170	179
KBH 50 P	50	6.15	9.75	16.0	23.1	30.2	43.5	66.1	75.9	83.9	94.6	111	157	179	213	224
KBH 54 P	54	6.64	10.5	17.3	25.0	32.7	47.0	72.4	84.6	93.6	107	128	186	215	263	280
KBH 59 P	59	7.26	11.5	18.9	27.3	35.7	51.3	79.1	92.5	102	116	139	203	235	288	306
KBH 64 P	64	7.87	12.5	20.5	29.6	38.8	55.6	85.8	100	111	126	151	220	255	312	332
KBH 69 P	69	8.49	13.5	22.1	31.9	41.8	60.0	92.5	108	120	136	163	237	275	336	358
KBH 79 P	79	9.72	15.4	25.3	36.5	47.8	68.7	106	124	138	156	187	272	315	385	410
KBH 88 P	88	10.8	17.2	28.2	40.7	53.3	76.5	118	138	153	174	208	302	350	429	457
KBH 98 P	98	12.1	19.1	31.4	45.3	59.4	85.2	131	154	171	193	231	337	390	477	509
KBH 103 P	103	12.7	20.1	33.0	47.6	62.4	89.6	138	161	179	203	243	354	410	502	534
KBH 110 P	110	13.5	21.5	35.2	50.9	66.6	95.6	147	172	191	217	260	378	438	536	571
KBH 118 P	118	14.5	23.0	37.8	54.6	71.5	103	158	185	205	233	279	406	470	575	612
KBH 127 P	127	15.6	24.8	40.6	58.7	76.9	110	170	199	221	251	300	437	506	619	659
KBH 137 P	137	16.9	26.7	43.8	63.4	83.0	119	184	215	239	270	323	471	546	667	711
KBH 140 P	140	17.2	27.3	44.8	64.7	84.8	122	188	219	244	276	331	481	557	682	726
KBH 157 P	157	19.3	30.6	50.2	72.6	95.1	137	210	246	273	310	371	540	625	765	815
KBH 170 P	170	20.9	33.2	54.4	78.6	103	148	228	266	296	336	401	584	677	828	882
KBH 177 P	177	21.8	34.5	56.6	81.9	107	154	237	277	308	349	418	608	705	862	918
KBH 185 P	185	22.8	36.1	59.2	85.6	112	161	248	290	322	365	437	636	737	901	960
KBH 196 P	196	24.1	38.2	62.7	90.6	119	170	263	307	341	387	463	674	780	955	1017
KBH 206 P	206	25.3	40.2	65.9	95.3	125	179	276	323	359	407	486	708	820	1003	1069
KBH 218 P	218	26.8	42.5	69.8	101	132	190	292	342	380	430	515	749	868	1062	1131
KBH 236 P	236	29.0	46.0	75.5	109	143	205	316	370	411	466	557	811	940	1150	1225
KBH 245 P	245	30.1	47.8	78.4	113	148	213	328	384	427	484	578	842	976	1193	1271
KBH 265 P	265	32.6	51.7	84.8	123	161	230	355	415	461	523	626	911	1055	1291	1375
KBH 275 P	275	33.8	53.6	88.0	127	167	239	369	431	479	543	649	945	1095	1340	1427
KBH 294 P	294	36.2	57.3	94.1	136	178	256	394	461	512	580	694	1011	1171	1432	1526
KBH 310 P	310	38.1	60.5	99.2	143	188	270	416	486	540	612	732	1066	1234	1510	1609
KBH 330 P	330	40.6	64.4	106	153	200	287	442	517	574	651	779	1134	1314	1607	1712
KBH 353 P	353	43.4	68.8	113	163	214	307	473	553	615	697	833	1213	1406	1719	1832
KBH 362 P	362	44.5	70.6	116	167	219	315	485	567	630	715	855	1244	1442	1763	1878
KBH 393 P	393	48.3	76.6	126	182	238	342	527	616	684	776	928	1351	1565	1914	2039
KBH 410 P	410	50.4	80.0	131	190	248	356	550	643	714	809	968	1409	1633	1997	2127
KBH 420 P	420	51.7	81.9	134	194	254	365	563	658	731	829	992	1444	1672	2046	2179
KBH 445 P	445	54.7	86.8	142	206	270	387	596	698	775	878	1051	1530	1772	2168	2309
KBH 471 P	471	57.9	91.8	151	218	285	410	631	738	820	930	1112	1619	1876	2294	2444
KBH 481 P	481	59.2	93.8	154	222	291	418	645	754	837	949	1136	1653	1915	2343	2496
KBH 491 P	491	60.4	95.7	157	227	297	427	658	770	855	969	1159	1688	1955	2392	2548
KBH 515 P	515	63.3	100	165	238	312	448	690	807	897	1017	1216	1770	2051	2509	2672
KBH 530 P	530	65.2	103	170	245	321	461	710	831	923	1046	1251	1822	2110	2582	2750
KBH 545 P	545	67.0	106	174	252	330	474	731	854	949	1076	1287	1873	2170	2655	2828
KBH 570 P	570	70.1	111	182	264	345	496	764	893	992	1125	1346	1959	2270	2776	2958
KBH 590 P	590	72.6	115	189	273	357	513	791	925	1027	1165	1393	2028	2349	2874	3062
KBH 615 P	615	75.6	120	197	284	372	535	808	934	1032	1163	1361	1932	2198	2617	2749
KBH 640 P	640	78.7	125	205	296	387	556	846	972	1074	1210	1416	2011	2287	2724	2861
KBH 670 P	670	82.4	131	214	310	405	583	885	1017	1124	1267	1483	2105	2395	2851	2995
KBH 695 P	695	85.5	136	222	321	420	604	918	1055	1166	1314	1538	2184	2484	2958	3107
KBH 705 P	705	86.7	137	226	326	427	613	932	1070	1183	1333	1560	2215	2520	3000	3151
KBH 725 P	725	89.2	141	232	335	439	630	958	1101	1216	1371	1605	2278	2591	3086	3241
KBH 765 P	765	94.1	149	245	354	463	665	1011	1161	1283	1447	1693	2404	2734	3256	3420
KBH 805 P	805	99.0	157	258	372	487	700	1064	1222	1351	1522	1782	2529	2877	3426	3598
KBH 840 P	840	103	164	269	388	508	730	1110	1275	1409	1589	1859	2639	3002	3575	3755
KBH 860 P	860	106	168	275	398	520	748	1136	1306	1443	1627	1903	2702	3074	3660	3845
KBH 890 P	890	109	174	285	412	538	774	1176	1351	1493	1683	1970	2796	3181	3788	3978
KBH 920 P	920	113	179	294	425	557	800	1216	1397	1544	1740	2036	2891	3288	3915	4112

Cell Performance H range

Performance after long term floating with constant voltage charging

Final Voltage: 1.05 V/cell

Available amperes at +20° C ± 5° C

Cell Type	C ₅ Ah	Hours						Minutes					Seconds			
		8	5	3	2	1.5	1	30	20	15	10	5	60	30	5	1
KBH 9 P	9	1.12	1.77	2.92	4.32	5.66	8.19	14.6	18.2	19.9	22.8	27.2	39.3	44.6	55.1	59.3
KBH 13 P	13	1.62	2.56	4.22	6.24	8.18	11.8	21.1	26.3	28.8	32.9	39.3	56.7	64.4	79.6	85.7
KBH 17 P	17	2.12	3.35	5.52	8.16	10.7	15.5	27.6	34.4	37.6	43.0	51.4	74.2	84.3	104	112
KBH 20 P	20	2.49	3.94	6.49	9.60	12.6	18.2	32.5	40.4	44.2	50.6	60.5	87.3	99.1	123	132
KBH 28 P	28	3.49	5.52	9.09	13.4	17.6	25.5	45.4	56.6	61.9	70.8	84.7	122	139	172	185
KBH 34 P	34	4.23	6.70	11.0	16.3	21.4	30.9	55.2	68.7	75.2	86.0	103	148	169	208	224
KBH 40 P	40	4.98	7.88	13.0	19.2	25.1	36.4	64.7	79.1	85.9	97.3	115	158	178	215	224
KBH 50 P	50	6.23	9.85	16.2	24.0	31.4	45.5	80.9	98.9	107	122	143	197	222	268	280
KBH 54 P	54	6.72	10.6	17.5	25.9	34.0	49.1	88.4	109	119	137	163	236	268	332	356
KBH 59 P	59	7.35	11.6	19.2	28.3	37.1	53.7	96.6	119	130	149	179	257	293	362	389
KBH 64 P	64	7.97	12.6	20.8	30.7	40.3	58.2	105	129	142	162	194	279	317	393	422
KBH 69 P	69	8.59	13.6	22.4	33.1	43.4	62.8	113	139	153	175	209	301	343	424	455
KBH 79 P	79	9.84	15.6	25.6	37.9	49.7	71.9	129	160	175	200	239	345	393	485	521
KBH 88 P	88	11.0	17.3	28.6	42.2	55.4	80.1	144	178	195	223	266	384	437	540	580
KBH 98 P	98	12.2	19.3	31.8	47.0	61.6	89.2	160	198	217	248	297	428	487	601	646
KBH 103 P	103	12.8	20.3	33.4	49.4	64.8	93.7	169	208	228	261	312	449	512	631	679
KBH 110 P	110	13.7	21.7	35.7	52.8	69.2	100	180	222	243	278	333	480	547	674	725
KBH 118 P	118	14.7	23.3	38.3	56.6	74.2	107	192	238	261	299	357	515	586	724	778
KBH 127 P	127	15.8	25.0	41.2	61.0	79.9	116	208	257	281	321	384	554	631	778	837
KBH 137 P	137	17.1	27.0	44.5	65.8	86.2	125	223	277	303	347	415	598	681	841	903
KBH 140 P	140	17.4	27.6	45.4	67.2	88.1	127	229	283	310	354	424	611	696	858	923
KBH 157 P	157	19.5	30.9	51.0	75.4	98.8	143	256	317	347	397	475	685	780	963	1035
KBH 170 P	170	21.2	33.5	55.2	81.6	107	155	278	344	376	430	514	742	845	1041	1121
KBH 177 P	177	22.0	34.9	57.5	85.0	111	161	289	358	391	448	536	772	880	1086	1167
KBH 185 P	185	23.0	36.5	60.1	88.8	116	168	303	374	409	468	560	807	919	1135	1220
KBH 196 P	196	24.4	38.6	63.6	94.1	123	178	320	396	434	496	594	855	974	1203	1292
KBH 206 P	206	25.6	40.6	66.9	98.9	130	187	337	416	456	521	623	899	1024	1264	1358
KBH 218 P	218	27.1	43.0	70.8	105	137	198	357	441	482	551	660	951	1083	1338	1437
KBH 236 P	236	29.4	46.5	76.6	113	148	215	385	477	522	597	715	1030	1173	1448	1556
KBH 245 P	245	30.5	48.3	79.5	118	154	223	401	495	542	620	741	1069	1217	1503	1615
KBH 265 P	265	33.0	52.2	86.0	127	167	241	432	535	586	670	803	1156	1317	1626	1747
KBH 275 P	275	34.2	54.2	89.3	132	173	250	450	556	608	696	832	1200	1367	1687	1813
KBH 294 P	294	36.6	57.9	95.4	141	185	268	479	594	650	744	890	1283	1461	1804	1938
KBH 310 P	310	38.6	61.1	101	149	195	282	508	626	686	784	938	1353	1540	1902	2044
KBH 330 P	330	41.1	65.0	107	158	208	300	540	667	730	835	998	1440	1640	2025	2176
KBH 353 P	353	43.9	69.6	115	169	222	321	576	713	781	893	1070	1540	1754	2166	2327
KBH 362 P	362	45.1	71.3	118	174	228	329	593	732	801	916	1095	1579	1799	2221	2387
KBH 393 P	393	48.9	77.5	128	189	247	358	641	794	869	994	1190	1715	1953	2411	2591
KBH 410 P	410	51.0	80.8	133	197	258	373	671	829	907	1037	1240	1789	2037	2516	2703
KBH 420 P	420	52.3	82.8	136	202	264	382	688	849	929	1062	1271	1833	2087	2577	2769
KBH 445 P	445	55.4	87.7	144	214	280	405	729	899	984	1126	1346	1942	2211	2730	2934
KBH 471 P	471	58.6	92.8	153	226	296	429	768	952	1042	1191	1427	2055	2340	2890	3105
KBH 481 P	481	59.9	94.8	156	231	303	438	788	972	1064	1217	1455	2099	2390	2951	3171
KBH 491 P	491	61.1	96.8	159	236	309	447	801	992	1086	1242	1487	2142	2440	3013	3237
KBH 515 P	515	64.1	102	167	247	324	469	843	1041	1139	1303	1558	2247	2559	3160	3395
KBH 530 P	530	66.0	104	172	254	333	482	868	1071	1172	1341	1604	2312	2634	3252	3494
KBH 545 P	545	67.9	107	177	262	343	496	893	1101	1205	1379	1649	2378	2708	3344	3593
KBH 570 P	570	71.0	112	185	274	359	519	934	1152	1261	1442	1725	2487	2832	3497	3758
KBH 590 P	590	73.5	116	192	283	371	537	962	1192	1305	1493	1785	2574	2932	3620	3890
KBH 615 P	615	76.6	121	200	295	387	559	995	1209	1321	1496	1762	2427	2737	3302	3445
KBH 640 P	640	79.7	126	208	307	402	582	1035	1265	1375	1557	1833	2525	2848	3436	3585
KBH 670 P	670	83.4	132	217	322	421	609	1083	1325	1440	1629	1919	2644	2981	3597	3753
KBH 695 P	695	86.5	137	226	334	437	632	1124	1374	1493	1690	1991	2743	3093	3731	3893
KBH 705 P	705	87.8	139	229	338	443	641	1140	1394	1515	1715	2020	2782	3138	3785	3949
KBH 725 P	725	90.3	143	235	348	456	659	1172	1433	1558	1763	2077	2861	3226	3892	4061
KBH 765 P	765	95.2	151	248	367	481	695	1237	1513	1644	1861	2192	3019	3404	4107	4285
KBH 805 P	805	100	159	261	386	506	732	1302	1592	1730	1958	2306	3177	3582	4322	4510
KBH 840 P	840	105	166	273	403	528	764	1358	1661	1805	2043	2406	3315	3738	4510	4706
KBH 860 P	860	107	170	279	413	541	782	1391	1700	1848	2092	2464	3394	3827	4617	4818
KBH 890 P	890	111	175	289	427	559	809	1439	1760	1912	2165	2550	3512	3960	4778	4986
KBH 920 P	920	115	181	299	442	578	836	1488	1819	1977	2238	2636	3630	4094	4939	5154

Cell Performance H range

Performance after long term floating with constant voltage charging

Final Voltage: 1.00 V/cell

Available amperes at +20° C ± 5° C

Cell Type	C ₅ Ah	Hours						Minutes					Seconds			
		8	5	3	2	1.5	1	30	20	15	10	5	60	30	5	1
KBH 9 P	9	1.14	1.80	2.96	4.40	5.79	8.47	15.5	20.9	23.8	27.2	33.0	46.7	53.0	66.7	73.2
KBH 13 P	13	1.64	2.60	4.28	6.35	8.36	12.2	22.4	30.1	34.4	39.3	47.7	67.5	76.6	96.4	106
KBH 17 P	17	2.15	3.40	5.59	8.30	10.9	16.0	29.3	39.4	44.9	51.4	62.4	88.3	100	126	138
KBH 20 P	20	2.52	4.00	6.58	9.77	12.9	18.8	34.5	46.4	52.9	60.4	73.4	104	118	148	163
KBH 28 P	28	3.53	5.60	9.21	13.7	18.0	26.3	48.3	64.9	74.0	84.6	103	145	165	208	228
KBH 34 P	34	4.29	6.80	11.2	16.6	21.9	32.0	58.6	78.8	89.9	103	125	177	200	252	276
KBH 40 P	40	5.05	8.00	13.2	19.5	25.7	37.6	68.2	91.8	103	117	139	190	213	260	276
KBH 50 P	50	6.31	10.0	16.5	24.4	32.1	47.0	85.3	115	129	146	174	238	267	325	345
KBH 54 P	54	6.82	10.8	17.8	26.4	34.7	50.8	93.1	125	143	163	198	280	318	400	439
KBH 59 P	59	7.45	11.8	19.5	28.8	38.0	55.5	102	137	156	178	217	306	348	437	480
KBH 64 P	64	8.08	12.8	21.1	31.3	41.2	60.2	110	148	169	193	235	332	377	474	520
KBH 69 P	69	8.71	13.8	22.8	33.7	44.4	64.9	119	160	182	209	253	358	406	512	561
KBH 79 P	79	9.97	15.8	26.1	38.6	50.8	74.3	136	183	209	239	290	410	465	586	642
KBH 88 P	88	11.1	17.6	29.1	43.0	56.6	82.8	152	204	233	266	323	457	518	652	716
KBH 98 P	98	12.4	19.6	32.4	47.9	63.1	92.2	169	227	259	296	360	509	577	727	797
KBH 103 P	103	13.0	20.6	34.0	50.3	66.3	96.9	178	239	272	311	378	535	607	764	838
KBH 110 P	110	13.9	22.0	36.3	53.7	70.8	103	190	255	291	332	404	571	648	816	894
KBH 118 P	118	14.9	23.6	39.0	57.6	75.9	111	204	274	312	357	433	613	695	875	960
KBH 127 P	127	16.0	25.4	41.9	62.0	81.7	119	219	294	336	384	466	660	748	942	1033
KBH 137 P	137	17.3	27.4	45.2	66.9	88.2	129	236	318	362	414	503	712	807	1016	1114
KBH 140 P	140	17.7	28.0	46.2	68.4	90.1	132	241	325	370	423	514	727	825	1038	1138
KBH 157 P	157	19.8	31.4	51.8	76.7	101	148	271	364	415	474	576	815	925	1164	1277
KBH 170 P	170	21.5	34.0	56.1	83.0	109	160	293	394	449	514	624	883	1001	1260	1382
KBH 177 P	177	22.3	35.4	58.4	86.4	114	166	305	411	468	535	651	919	1043	1312	1439
KBH 185 P	185	23.4	37.0	61.1	90.4	119	174	319	429	489	559	679	961	1090	1372	1504
KBH 196 P	196	24.7	39.2	64.7	95.7	126	184	338	455	518	592	719	1018	1155	1453	1594
KBH 206 P	206	26.0	41.2	68.0	101	133	194	355	478	544	623	756	1070	1213	1527	1675
KBH 218 P	218	27.5	43.6	72.0	106	140	205	376	505	576	659	800	1132	1284	1616	1773
KBH 236 P	236	29.8	47.2	77.9	115	152	222	407	548	624	713	867	1226	1390	1750	1919
KBH 245 P	245	30.9	49.0	80.9	120	158	230	423	568	648	740	899	1272	1443	1816	1992
KBH 265 P	265	33.5	53.0	87.5	129	171	249	457	615	700	801	973	1376	1561	1965	2155
KBH 275 P	275	34.7	55.0	90.8	134	177	259	474	638	727	831	1009	1428	1620	2039	2236
KBH 294 P	294	37.1	58.8	97.1	144	189	277	507	682	777	888	1079	1527	1732	2180	2391
KBH 310 P	310	39.1	62.0	102	151	199	292	535	719	819	937	1138	1610	1826	2298	2521
KBH 330 P	330	41.7	66.0	109	161	212	310	569	765	872	997	1211	1714	1944	2447	2683
KBH 353 P	353	44.6	70.6	117	172	227	332	609	820	933	1067	1296	1833	2079	2617	2870
KBH 362 P	362	45.7	72.4	120	177	233	340	624	839	957	1094	1329	1880	2132	2684	2944
KBH 393 P	393	49.6	78.6	130	192	253	370	678	912	1039	1188	1443	2041	2315	2914	3196
KBH 410 P	410	51.8	82.0	135	200	264	386	707	951	1084	1239	1505	2129	2415	3040	3334
KBH 420 P	420	53.0	84.0	139	205	270	395	724	974	1110	1269	1542	2181	2474	3114	3415
KBH 445 P	445	56.2	89.0	147	217	286	419	768	1032	1176	1345	1633	2311	2621	3299	3619
KBH 471 P	471	59.5	94.2	155	230	303	443	812	1093	1245	1423	1730	2446	2774	3492	3830
KBH 481 P	481	60.7	96.2	159	235	310	452	830	1115	1271	1454	1766	2498	2833	3566	3911
KBH 491 P	491	62.0	98.2	162	240	316	462	847	1139	1298	1484	1803	2550	2892	3640	3993
KBH 515 P	515	65.0	103	170	252	331	484	888	1194	1361	1556	1890	2675	3034	3818	4188
KBH 530 P	530	66.9	106	175	259	341	498	914	1229	1401	1602	1946	2753	3122	3929	4310
KBH 545 P	545	68.8	109	180	266	351	513	940	1264	1440	1647	2001	2831	3210	4041	4432
KBH 570 P	570	72.0	114	188	278	367	536	983	1322	1507	1723	2092	2960	3358	4226	4635
KBH 590 P	590	74.5	118	195	288	380	555	1018	1369	1559	1783	2168	3064	3475	4374	4798
KBH 615 P	615	77.6	123	203	300	395	578	1049	1411	1579	1792	2135	2924	3282	3992	4245
KBH 640 P	640	80.8	128	211	312	411	602	1092	1468	1648	1867	2222	3043	3416	4155	4417
KBH 670 P	670	84.6	134	221	327	430	630	1143	1537	1726	1955	2326	3186	3576	4349	4624
KBH 695 P	695	87.7	139	229	339	446	653	1186	1594	1790	2028	2413	3305	3709	4512	4797
KBH 705 P	705	89.0	141	232	344	453	663	1203	1617	1816	2057	2448	3352	3762	4577	4866
KBH 725 P	725	91.5	145	239	354	466	682	1237	1663	1867	2115	2517	3448	3869	4706	5004
KBH 765 P	765	96.6	153	252	373	491	719	1305	1755	1970	2232	2656	3638	4083	4966	5280
KBH 805 P	805	102	161	265	393	517	757	1373	1847	2073	2348	2795	3828	4296	5226	5556
KBH 840 P	840	106	168	277	410	539	790	1433	1927	2164	2451	2917	3994	4483	5453	5798
KBH 860 P	860	109	172	284	420	552	809	1467	1973	2215	2509	2986	4089	4590	5583	5936
KBH 890 P	890	112	178	293	435	572	837	1518	2042	2292	2596	3090	4232	4750	5777	6143
KBH 920 P	920	116	184	303	449	591	865	1569	2111	2370	2684	3194	4375	4910	5972	6350
KBH 930 P	930	117	186	307	454	597	874	1586	2134	2395	2713	3229	4422	4963	6037	6419

M Range

Cell dimensions

Cell Type	Capacity at the 5 hr rate (Ah)	Cell Dimensions in mm						Cell connection bolt size	Container size reference	Reserve electrolyte cc/cell	Approx Weight(Kg) 1.2 V Block
		Height	Width	Length							
				1.2 V L (1)	2.4 V L (2)	3.6 V L (3)					
KBM 12 P	12	264	123		69	100	M8	B21-1	90	1.1	
KBM 16 P	16	264	123		69	100	M8	B21-1	90	1.3	
KBM 23 P	23	264	123		79	115	M8	B22-1	110	1.6	
KBM 26 P	26	264	123		79	115	M8	B22-1	110	1.8	
KBM 34 P	34	264	123		103	151	M8	B23-1	145	2.4	
KBM 44 P	44	264	123		127	187	M8	B24-1	185	3.5	
KBM 48 P	48	264	123		127	187	M8	B24-1	185	3.7	
KBM 57 P	57	405	195		79	115	M10	B45-1	280	4.2	
KBM 67 P	67	405	195		79	115	M10	B45-1	280	4.5	
KBM 75 P	75	405	195		79	115	M10	B45-1	280	5.0	
KBM 84 P	84	405	195		79	115	M10	B45-1	280	5.1	
KBM 95 P	95	405	195		94	137	M10	B44-1	350	5.6	
KBM 112 P	112	405	195		94	137	M10	B44-1	350	6.1	
KBM 138 P	138	405	195		115	169	M10	B42A-1	450	7.5	
KBM 148 P	148	405	195		127	187	M10	B42-1	515	8.0	
KBM 161 P	161	405	195		127	187	M10	B42-1	515	8.6	
KBM 184 P	184	405	195		159	232	M10	B41B-1	650	9.8	
KBM 195 P	195	405	195		183	268	M10	B41-1	745	11.1	
KBM 208 P	208	405	195		183	268	M10	B41-1	745	11.4	
KBM 231 P	231	405	195		183	268	M10	B41-1	745	11.9	
KBM 277 P	277	405	195	120	228	336	2 x M10	B42A-2	900	14.4	
KBM 310 P	310	405	195	132	252	372	2 x M10	B42-2	1030	16.6	
KBM 323 P	323	405	195	132	252	372	2 x M10	B42-2	1030	17.2	
KBM 350 P	350	405	195	159	304		2 x M10	B41B-2	1300	18.8	
KBM 369 P	369	405	195	159	304		2 x M10	B41B-2	1300	19.6	
KBM 375 P	375	405	195	183	352		2 x M10	B41-2	1490	20.2	
KBM 400 P	400	405	195	183	352		2 x M10	B41-2	1490	22.4	
KBM 415 P	415	405	195	183			2 x M10	B41-2	1490	22.8	
KBM 438 P	438	405	195	183			2 x M10	B41-2	1490	23.2	
KBM 461 P	461	405	195	183			2 x M10	B41-2	1490	24.0	
KBM 480 P	480	405	195	232			3 x M10	B41B-3	1950	27.5	
KBM 495 P	495	405	195	232			3 x M10	B41B-3	1950	28.0	
KBM 540 P	540	405	195	232			3 x M10	B41B-3	1950	29.0	
KBM 555 P	555	405	195	232			3 x M10	B41B-3	1950	29.4	
KBM 590 P	590	405	195	268			3 x M10	B41-3	2235	33.0	
KBM 625 P	625	405	195	268			3 x M10	B41-3	2235	34.2	
KBM 650 P	650	405	195	268			3 x M10	B41-3	2235	35.0	
KBM 690 P	690	405	195	268			3 x M10	B41-3	2235	35.4	
KBM 705 P	705	405	195	268			3 x M10	B41-3	2235	35.9	
KBM 740 P	740	405	195	304			4 x M10	B41B-4	2600	39.2	
KBM 770 P	770	405	195	352			4 x M10	B41-4	2980	43.5	
KBM 805 P	805	405	195	352			4 x M10	B41-4	2980	44.2	
KBM 830 P	830	405	195	352			4 x M10	B41-4	2980	44.5	
KBM 870 P	870	405	195	352			4 x M10	B41-4	2980	46.0	
KBM 890 P	890	405	195	352			4 x M10	B41-4	2980	46.8	
KBM 920 P	920	405	195	352			4 x M10	B41-4	2980	47.6	
KBM 940 P	940	405	195	352			4 x M10	B41-4	2980	48.2	
KBM 965 P	965	405	195	372			6 x M10	B42-6	3090	51.0	
KBM 1000 P	1000	405	195	378			5 x M10	B41B-5	3250	51.2	
KBM 1040 P	1040	405	195	437			5 x M10	B41-5	3725	55.7	
KBM 1100 P	1100	405	195	437			5 x M10	B41-5	3725	59.0	
KBM 1150 P	1150	405	195	437			5 x M10	B41-5	3725	62.7	
KBM 1180 P	1180	405	195	437			5 x M10	B41-5	3725	63.2	
KBM 1225 P	1225	405	195	522			6 x M10	B41-6	4470	66.2	
KBM 1270 P	1270	405	195	522			6 x M10	B41-6	4470	67.8	
KBM 1330 P	1330	405	195	522			6 x M10	B41-6	4470	69.2	
KBM 1390 P	1390	405	195	522			6 x M10	B41-6	4470	70.8	

- ✓ Block types starting from KBM 184 P shall have handles.
- ✓ Cell ranges other than listed above can be supplied on request. The Parameters and performance will proportionately change.

Cell Performance **M** range

Performance fully charged with constant current charging

Final Voltage: 1.14V/cell

Available amperes at +20° C ± 5° C

Cell Type	C _s Ah	Hours							Minutes					Seconds			
		8	5	3	2	1.5	1	30	20	15	10	5	60	30	5	1	
KBM 12 P	12	1.44	2.26	3.58	4.96	6.00	7.20	9.60	11.3	12.6	14.4	17.7	24.2	27.2	31.7	32.8	
KBM 16 P	16	1.92	3.01	4.78	6.61	8.00	9.60	12.8	15.1	16.8	19.2	23.6	32.3	36.3	42.3	43.7	
KBM 23 P	23	2.76	4.32	6.88	9.50	11.5	13.8	18.4	21.6	23.9	27.6	33.0	46.5	52.2	60.8	62.8	
KBM 26 P	26	3.12	4.89	7.78	10.7	13.0	15.6	20.8	24.5	27.1	31.2	37.2	52.5	59.0	68.8	71.0	
KBM 34 P	34	4.08	6.39	10.2	14.0	17.0	20.4	27.2	32.0	35.4	40.8	48.7	68.7	77.1	89.9	92.9	
KBM 44 P	44	5.28	8.27	13.2	18.2	22.0	26.4	35.2	41.4	45.8	52.8	63.0	88.9	99.8	116	120	
KBM 48 P	48	5.76	9.03	14.4	19.8	24.0	28.8	38.4	45.2	50.0	57.6	68.8	97.0	109	127	131	
KBM 57 P	57	6.84	10.7	17.1	23.9	29.4	35.9	47.8	55.9	61.6	70.1	83.9	118	131	150	156	
KBM 67 P	67	8.04	12.6	20.1	28.3	34.5	42.2	56.2	65.8	72.4	82.4	98.7	138	154	177	183	
KBM 75 P	75	9.00	14.1	22.5	31.5	38.6	47.3	62.9	73.6	81.1	92.3	110	155	172	198	205	
KBM 84 P	84	10.1	15.8	25.2	35.3	43.3	52.9	70.5	82.4	90.8	103	124	173	193	222	230	
KBM 95 P	95	11.4	17.9	28.5	39.9	48.9	59.9	79.6	93.2	103	117	140	196	218	251	260	
KBM 112 P	112	13.4	21.1	33.6	47.1	57.7	70.6	94.0	110	121	138	165	231	257	296	306	
KBM 138 P	138	16.6	25.9	41.4	58.0	71.1	87.0	116	135	149	170	203	285	317	365	377	
KBM 148 P	148	17.8	27.8	44.4	62.2	76.2	93.3	124	145	160	182	218	305	339	391	404	
KBM 161 P	161	19.3	30.3	48.3	67.6	82.9	101	135	158	174	198	237	332	369	425	440	
KBM 184 P	184	22.1	34.6	55.2	77.3	94.8	116	155	181	199	226	271	379	422	486	503	
KBM 195 P	195	23.4	36.7	58.5	81.9	100	123	164	191	211	240	287	402	447	515	533	
KBM 208 P	208	25.0	39.1	62.4	87.4	107	131	175	204	225	256	306	429	477	549	568	
KBM 231 P	231	27.7	43.4	69.3	97.1	119	146	194	227	250	284	340	476	530	610	631	
KBM 277 P	277	33.2	52.1	83.1	116	143	174	233	272	299	341	408	571	635	732	757	
KBM 310 P	310	37.2	58.3	93.0	130	160	195	261	304	335	381	457	639	711	819	847	
KBM 323 P	323	38.8	60.7	96.9	136	166	203	271	317	349	397	476	666	741	853	883	
KBM 350 P	350	42.0	65.8	105	147	180	221	294	343	378	431	515	722	803	924	956	
KBM 369 P	369	44.3	69.4	111	155	190	232	310	362	399	454	543	761	846	975	1008	
KBM 375 P	375	45.0	70.5	112	158	193	236	315	368	405	461	552	773	860	990	1025	
KBM 400 P	400	48.0	75.2	120	168	206	252	336	393	432	492	589	825	917	1056	1093	
KBM 415 P	415	49.8	78.0	124	174	213	261	349	407	449	510	611	856	952	1096	1134	
KBM 438 P	438	52.6	82.3	131	184	225	276	368	430	474	539	645	903	1005	1157	1197	
KBM 461 P	461	55.3	86.7	138	194	237	290	387	452	498	567	679	951	1057	1218	1260	
KBM 480 P	480	57.6	90.2	144	202	247	302	403	471	519	590	707	990	1101	1268	1311	
KBM 495 P	495	59.4	93.1	148	208	255	312	416	486	535	609	729	1021	1135	1307	1352	
KBM 540 P	540	64.8	102	162	227	278	340	454	530	584	664	795	1113	1239	1426	1475	
KBM 555 P	555	66.6	104	166	233	285	350	466	545	600	683	817	1144	1273	1466	1516	
KBM 590 P	590	70.8	111	177	248	304	372	496	579	638	726	869	1216	1353	1558	1612	
KBM 625 P	625	75.0	118	187	263	321	394	525	613	676	769	920	1289	1433	1651	1708	
KBM 650 P	650	78.0	122	195	273	335	410	546	638	703	800	957	1340	1491	1717	1776	
KBM 690 P	690	82.8	130	207	290	356	435	580	677	746	849	1016	1423	1581	1821	1886	
KBM 705 P	705	84.6	133	211	296	363	444	592	692	762	867	1038	1454	1617	1862	1926	
KBM 740 P	740	88.8	139	222	311	380	466	622	726	800	910	1090	1526	1697	1955	2022	
KBM 770 P	770	92.4	145	231	324	397	485	647	756	832	947	1134	1588	1766	2034	2104	
KBM 805 P	805	96.6	151	241	338	415	507	676	790	870	990	1186	1660	1846	2126	2199	
KBM 830 P	830	99.6	156	249	349	427	523	697	815	897	1021	1222	1711	1904	2192	2268	
KBM 870 P	870	104	164	261	366	448	548	731	854	941	1070	1281	1794	1995	2298	2377	
KBM 890 P	890	107	167	267	374	459	561	748	873	962	1095	1311	1835	2041	2351	2432	
KBM 920 P	920	110	173	276	387	473	579	773	903	995	1132	1355	1897	2110	2430	2514	
KBM 940 P	940	113	177	283	395	484	592	789	922	1016	1156	1384	1938	2154	2481	2569	
KBM 965 P	965	116	181	289	405	496	608	811	947	1043	1187	1421	1990	2213	2549	2637	
KBM 1000P	1000	120	188	300	420	515	630	840	981	1081	1230	1473	2062	2294	2641	2732	
KBM 1040P	1040	125	196	312	437	535	655	874	1021	1124	1279	1532	2144	2385	2747	2842	
KBM 1100P	1100	132	207	330	462	567	693	924	1079	1189	1353	1620	2268	2523	2905	3005	
KBM 1150P	1150	138	216	346	483	593	725	965	1129	1243	1414	1693	2371	2636	3035	3143	
KBM 1180P	1180	142	222	354	496	608	744	992	1158	1276	1451	1738	2433	2706	3117	3224	
KBM 1225P	1225	147	230	369	515	631	772	1028	1202	1324	1507	1803	2526	2808	3234	3348	
KBM 1270P	1270	152	239	381	534	654	800	1067	1246	1373	1562	1870	2619	2913	3354	3470	
KBM 1330P	1330	160	250	399	559	685	838	1118	1305	1438	1636	1959	2742	3050	3513	3634	
KBM 1390P	1390	167	261	417	584	715	876	1168	1363	1503	1710	2047	2866	3188	3671	3798	

Cell Performance M range

Performance fully charged with constant current charging

Final Voltage: 1.10 V/cell

Available amperes at +20° C ± 5° C

Cell Type	C _s Ah	Hours							Minutes					Seconds			
		8	5	3	2	1.5	1	30	20	15	10	5	60	30	5	1	
KBM 12 P	12	1.48	2.34	3.74	5.31	6.63	8.39	11.3	13.2	14.5	16.6	20.0	28.4	32.2	40.7	44.4	
KBM 16 P	16	1.97	3.12	4.99	7.08	8.84	11.2	15.1	17.6	19.4	22.1	26.7	37.9	42.9	54.2	59.3	
KBM 23 P	23	2.83	4.49	7.18	10.2	12.7	16.1	21.6	25.3	27.8	31.8	38.4	54.5	61.7	78.0	85.2	
KBM 26 P	26	3.20	5.07	8.11	11.5	14.4	18.2	24.5	28.6	31.5	35.9	43.4	61.6	69.7	88.1	96.3	
KBM 34 P	34	4.18	6.63	10.6	15.0	18.8	23.8	32.0	37.4	41.1	47.0	56.8	80.6	91.2	115	126	
KBM 44 P	44	5.41	8.58	13.8	19.5	24.3	30.8	41.4	48.4	53.3	60.8	73.5	104	118	149	163	
KBM 48 P	48	5.90	9.36	15.0	21.4	26.5	33.6	45.2	52.8	58.1	66.3	80.1	114	129	163	178	
KBM 57 P	57	7.01	11.1	18.0	25.5	32.1	41.8	55.9	65.5	71.9	82.1	98.1	137	153	180	191	
KBM 67 P	67	8.24	13.1	21.1	30.0	37.8	49.1	65.8	77.0	84.5	96.5	115	161	179	212	225	
KBM 75 P	75	9.23	14.6	23.6	33.5	42.3	55.0	73.6	86.2	94.6	108	129	180	201	237	251	
KBM 84 P	84	10.3	16.4	26.5	37.6	47.4	61.6	82.4	96.6	106	121	145	202	225	266	282	
KBM 95 P	95	11.7	18.5	29.9	42.5	53.6	69.6	93.2	109	120	137	164	228	254	300	318	
KBM 112 P	112	13.8	21.8	35.3	50.1	63.2	82.1	110	129	141	161	193	269	300	354	375	
KBM 138 P	138	17.0	26.9	43.5	61.7	77.8	101	135	159	174	199	238	331	370	436	463	
KBM 148 P	148	18.2	28.9	46.6	66.2	83.5	109	145	170	187	213	255	355	396	468	496	
KBM 161 P	161	19.8	31.4	50.7	72.0	90.8	118	158	185	203	232	277	386	431	509	540	
KBM 184 P	184	22.6	35.9	58.0	82.3	104	135	181	212	232	265	317	441	493	582	617	
KBM 195 P	195	24.0	38.0	61.4	87.2	110	143	191	224	246	281	336	468	522	617	654	
KBM 208 P	208	25.6	40.6	65.5	93.0	117	152	204	239	262	300	358	499	557	658	697	
KBM 231 P	231	28.4	45.0	72.8	103	130	169	227	266	291	333	398	554	619	730	774	
KBM 277 P	277	34.1	54.0	87.3	124	156	203	272	319	349	399	477	665	742	876	929	
KBM 310 P	310	38.1	60.5	97.7	139	175	227	304	356	391	447	534	744	830	980	1039	
KBM 323 P	323	39.7	63.0	102	144	182	237	317	371	407	465	556	775	865	1021	1083	
KBM 350 P	350	43.1	68.3	110	157	197	257	343	402	441	504	602	839	937	1107	1173	
KBM 369 P	369	45.4	72.0	116	165	208	271	362	424	465	532	635	885	988	1167	1237	
KBM 375 P	375	46.1	73.1	118	168	212	275	368	431	473	540	645	899	1004	1186	1257	
KBM 400 P	400	49.2	78.0	126	179	226	293	393	460	504	576	688	960	1071	1265	1339	
KBM 415 P	415	51.0	80.9	131	186	234	304	407	477	523	598	714	996	1111	1312	1391	
KBM 438 P	438	53.9	85.4	138	196	247	321	430	504	552	631	754	1051	1173	1385	1468	
KBM 461 P	461	56.7	89.9	145	206	260	338	452	530	581	664	793	1106	1234	1457	1545	
KBM 480 P	480	59.0	93.6	151	215	271	352	471	552	605	692	826	1151	1285	1518	1609	
KBM 495 P	495	60.9	96.5	156	221	279	363	486	569	624	713	852	1188	1325	1565	1659	
KBM 540 P	540	66.4	105	170	242	305	396	530	621	681	778	929	1295	1446	1707	1810	
KBM 555 P	555	68.3	108	175	248	313	407	545	638	700	800	955	1332	1486	1755	1861	
KBM 590 P	590	72.6	115	186	264	333	433	579	678	744	850	1015	1415	1580	1865	1978	
KBM 625 P	625	76.9	122	197	280	353	458	613	719	788	901	1076	1500	1674	1976	2095	
KBM 650 P	650	80.0	127	205	291	367	477	638	747	820	937	1119	1559	1741	2055	2179	
KBM 690 P	690	84.9	135	217	309	389	506	677	794	870	994	1187	1655	1848	2181	2310	
KBM 705 P	705	86.7	137	222	315	398	517	692	810	889	1016	1213	1691	1888	2229	2363	
KBM 740 P	740	91.0	144	233	331	417	543	726	851	933	1066	1274	1775	1982	2340	2481	
KBM 770 P	770	94.7	150	243	344	434	565	756	885	971	1110	1325	1847	2062	2434	2581	
KBM 805 P	805	99.0	157	254	360	454	590	790	925	1015	1160	1386	1930	2156	2545	2699	
KBM 830 P	830	102	162	261	371	468	609	815	955	1047	1196	1429	1991	2223	2624	2782	
KBM 870 P	870	107	170	274	389	491	638	854	1000	1097	1254	1497	2086	2330	2751	2917	
KBM 890 P	890	109	174	280	398	502	652	873	1023	1122	1282	1532	2134	2383	2814	2984	
KBM 920 P	920	113	179	290	411	519	674	903	1058	1160	1326	1583	2207	2464	2909	3084	
KBM 940 P	940	116	183	296	420	530	689	922	1080	1185	1355	1617	2254	2517	2972	3147	
KBM 965 P	965	119	188	304	432	544	707	947	1110	1217	1390	1661	2315	2584	3051	3235	
KBM 1000P	1000	123	195	315	447	564	733	981	1149	1261	1441	1721	2398	2678	3162	3352	
KBM 1040P	1040	128	203	328	465	587	762	1021	1196	1311	1499	1790	2495	2785	3288	3486	
KBM 1100P	1100	135	215	347	492	620	806	1079	1264	1387	1585	1893	2638	2946	3478	3688	
KBM 1150P	1150	141	224	362	514	649	843	1129	1322	1450	1657	1979	2758	3079	3636	3850	
KBM 1180P	1180	145	230	372	528	666	865	1158	1356	1488	1700	2031	2830	3160	3731	3956	
KBM 1225P	1225	151	239	386	548	691	898	1202	1408	1545	1765	2108	2938	3280	3873	4101	
KBM 1270P	1270	156	248	400	568	716	931	1246	1460	1602	1830	2186	3046	3401	4015	4257	
KBM 1330P	1330	164	259	419	595	750	975	1305	1529	1677	1916	2289	3189	3561	4205	4459	
KBM 1390P	1390	171	271	438	622	784	1019	1364	1599	1753	2003	2392	3335	3722	4395	4660	

Cell Performance M range

Performance fully charged with constant current charging

Final Voltage: 1.05 V/cell

Available amperes at +20° C ± 5° C

Cell Type	C _s Ah	Hours							Minutes					Seconds			
		8	5	3	2	1.5	1	30	20	15	10	5	60	30	5	1	
KBM 12 P	12	1.50	2.38	3.86	5.61	7.10	9.49	13.0	15.2	16.9	19.4	23.5	33.3	37.4	44.4	48.0	
KBM 16 P	16	2.00	3.17	5.15	7.48	9.47	12.7	17.4	20.3	22.5	25.8	31.4	44.4	49.8	59.3	64.0	
KBM 23 P	23	2.88	4.56	7.40	10.7	13.6	18.2	25.0	29.1	32.4	37.1	45.1	63.9	71.7	85.2	92.0	
KBM 26 P	26	3.25	5.15	8.37	12.1	15.4	20.6	28.3	32.9	36.6	41.9	51.0	72.2	81.0	96.3	104	
KBM 34 P	34	4.25	6.73	10.9	15.9	20.1	26.9	37.0	43.0	47.9	54.8	66.7	94.4	106	126	136	
KBM 44 P	44	5.50	8.71	14.2	20.6	26.0	34.8	48.1	55.7	62.0	71.0	86.3	122	137	163	176	
KBM 48 P	48	6.00	9.51	15.5	22.4	28.4	38.0	52.2	60.8	67.6	77.4	94.1	133	150	174	186	
KBM 57 P	57	7.13	11.3	18.4	26.7	34.2	46.7	65.5	76.4	84.4	95.8	115	160	180	212	228	
KBM 67 P	67	8.38	13.3	21.6	31.3	40.2	54.9	77.0	89.8	99.2	113	135	188	211	249	268	
KBM 75 P	75	9.38	14.8	24.2	35.08	45.0	61.5	86.2	100	111	126	152	210	236	279	300	
KBM 84 P	84	10.5	16.6	27.1	39.3	50.4	68.9	96.6	113	124	141	170	235	265	312	336	
KBM 95 P	95	11.9	18.8	30.7	44.4	57.0	77.9	109	127	141	160	192	266	299	353	380	
KBM 112 P	112	14.0	22.2	36.2	52.4	67.2	91.8	129	150	166	188	226	314	353	416	448	
KBM 138 P	138	17.3	27.3	44.6	64.6	82.8	113	159	185	204	232	279	387	435	513	553	
KBM 148 P	148	18.5	29.2	47.8	69.2	88.8	121	170	198	219	249	299	415	467	550	593	
KBM 161 P	161	20.1	31.9	52.0	75.3	96.6	132	185	216	238	271	325	451	508	598	645	
KBM 184 P	184	23.0	36.4	59.5	86.1	110	151	212	246	272	309	372	515	580	683	737	
KBM 195 P	195	24.4	38.5	63.0	91.2	117	160	224	261	288	328	394	546	615	724	781	
KBM 208 P	208	26.0	41.2	67.2	97.3	125	171	239	279	308	350	420	583	656	773	833	
KBM 231 P	231	28.9	45.7	74.6	108	139	189	266	309	342	388	467	647	728	858	925	
KBM 277 P	277	34.6	54.9	89.5	130	166	227	319	371	410	466	560	776	873	1029	1109	
KBM 310 P	310	38.8	61.4	100	145	186	254	356	415	459	521	626	868	977	1151	1241	
KBM 323 P	323	40.4	64.0	104	151	194	265	371	433	478	543	653	905	1018	1200	1293	
KBM 350 P	350	43.8	69.3	113	164	210	287	402	469	518	588	707	980	1103	1300	1402	
KBM 369 P	369	46.1	73.1	119	173	221	303	424	494	546	620	745	1034	1163	1370	1478	
KBM 375 P	375	46.9	74.1	121	175	225	307	431	502	555	630	758	1050	1182	1393	1502	
KBM 400 P	400	50.0	78.8	129	187	240	328	460	537	591	671	808	1120	1261	1483	1600	
KBM 415 P	415	51.9	82.2	134	194	249	340	477	556	614	697	838	1162	1308	1541	1662	
KBM 438 P	438	54.8	86.7	142	205	263	359	504	587	648	736	885	1227	1381	1627	1754	
KBM 461 P	461	57.6	91.5	149	216	277	378	530	618	682	775	931	1291	1453	1712	1846	
KBM 480 P	480	60.0	94.9	155	225	288	393	552	643	710	807	970	1345	1513	1783	1922	
KBM 495 P	495	61.9	98	160	232	297	406	569	663	732	832	1000	1387	1561	1838	1982	
KBM 540 P	540	67.5	107	174	253	324	443	621	723	799	908	1091	1513	1702	2006	2162	
KBM 555 P	555	69.4	110	179	260	333	455	638	743	821	933	1121	1555	1750	2061	2222	
KBM 590 P	590	73.8	117	191	276	354	484	678	790	873	992	1192	1653	1860	2191	2363	
KBM 625 P	625	78.1	124	202	292	375	513	719	837	925	1050	1263	1751	1970	2321	2503	
KBM 650 P	650	81.3	128	210	304	390	533	747	871	962	1092	1313	1821	2049	2414	2603	
KBM 690 P	690	86.3	136	223	323	414	566	793	926	1020	1158	1394	1933	2173	2559	2760	
KBM 705 P	705	88.1	139	228	330	423	578	810	944	1043	1185	1424	1975	2223	2618	2823	
KBM 740 P	740	92.5	147	239	346	444	607	851	991	1095	1244	1495	2073	2333	2748	2963	
KBM 770 P	770	96.3	152	249	360	462	631	885	1031	1139	1294	1556	2157	2427	2860	3083	
KBM 805 P	805	101	159	260	377	483	660	925	1078	1191	1353	1626	2255	2538	2990	3223	
KBM 830 P	830	104	164	268	388	498	681	954	1112	1228	1395	1677	2325	2617	3083	3324	
KBM 870 P	870	109	172	281	407	522	713	1000	1165	1287	1462	1758	2437	2743	3231	3484	
KBM 890 P	890	111	176	288	416	534	730	1023	1192	1317	1496	1798	2493	2806	3305	3564	
KBM 920 P	920	115	182	297	431	552	755	1058	1232	1362	1546	1859	2577	2900	3417	3684	
KBM 940 P	940	118	185	304	440	564	771	1080	1261	1390	1576	1897	2633	2961	3486	3760	
KBM 965 P	965	121	191	312	452	579	791	1110	1293	1428	1618	1948	2703	3039	3579	3860	
KBM 1000P	1000	125	198	323	468	600	820	1149	1340	1479	1677	2019	2801	3150	3709	4000	
KBM 1040P	1040	130	206	336	487	624	853	1196	1393	1539	1744	2099	2913	3276	3857	4160	
KBM 1100P	1100	138	217	355	514	660	902	1264	1474	1627	1844	2220	3081	3465	4079	4400	
KBM 1150P	1150	144	227	372	538	690	943	1321	1543	1701	1928	2321	3221	3622	4265	4600	
KBM 1180P	1180	148	233	381	552	708	967	1356	1581	1746	1979	2382	3305	3717	4376	4720	
KBM 1225P	1225	153	241	396	573	735	1004	1408	1643	1811	2054	2473	3432	3858	4543	4900	
KBM 1270P	1270	159	251	410	594	762	1041	1460	1701	1879	2129	2564	3557	4000	4710	5080	
KBM 1330P	1330	166	263	430	622	798	1090	1529	1782	1967	2230	2685	3725	4189	4932	5320	
KBM 1390P	1390	174	275	449	650	834	1140	1598	1862	2057	2331	2806	3894	4378	5155	5560	
KBM 1460P	1460	183	288	472	683	876	1197	1678	1959	2158	2448	2947	4090	4598	5414	5840	

Cell Performance **M** range
 Performance fully charged with constant current charging

Final Voltage: 1.00 V/cell

Available amperes at +20° C ± 5° C

Cell Type	C _s Ah	Hours							Minutes					Seconds			
		8	5	3	2	1.5	1	30	20	15	10	5	60	30	5	1	
KBM 12 P	12	1.51	2.40	3.92	5.73	7.42	10.2	14.6	17.2	19.0	21.7	26.5	37.7	42.9	51.3	54.3	
KBM 16 P	16	2.02	3.20	5.23	7.63	9.89	13.6	19.5	22.9	25.3	29.0	35.3	50.3	57.1	68.4	72.4	
KBM 23 P	23	2.90	4.60	7.52	11.0	14.2	19.6	28.0	33.0	36.4	41.7	50.8	72.4	82.1	98.3	104	
KBM 26 P	26	3.28	5.20	8.50	12.4	16.1	22.1	31.7	37.2	41.1	47.1	57.4	81.9	92.9	111	118	
KBM 34 P	34	4.28	6.80	11.1	16.2	21.0	28.9	41.5	48.7	53.8	61.6	75.1	107	121	145	154	
KBM 44 P	44	5.54	8.80	14.4	21.0	27.2	37.4	53.7	63.0	69.6	79.7	97.1	138	157	188	199	
KBM 48 P	48	6.05	9.60	15.7	22.9	29.7	40.8	58.5	68.8	75.9	87.0	106	151	171	205	217	
KBM 57 P	57	7.18	11.4	18.7	27.3	35.3	49.0	73.6	86.0	95.2	109	132	184	205	245	259	
KBM 67 P	67	8.44	13.4	21.9	32.0	41.5	57.6	86.6	101	112	128	155	216	241	288	305	
KBM 75 P	75	9.45	15.0	24.5	35.9	46.5	64.5	96.9	113	125	143	173	242	270	322	341	
KBM 84 P	84	10.6	16.8	27.5	40.2	52.1	72.2	109	127	140	161	194	271	303	361	382	
KBM 95 P	95	12.0	19.0	31.1	45.4	58.9	81.7	123	143	159	182	220	306	342	408	432	
KBM 112 P	112	14.1	22.4	36.7	53.6	69.4	96.3	145	169	187	214	259	361	403	481	509	
KBM 138 P	138	17.4	27.6	45.2	66.0	85.6	119	178	208	231	264	319	445	497	593	627	
KBM 148 P	148	18.6	29.6	48.4	70.8	91.8	127	191	223	247	283	342	477	533	636	673	
KBM 161 P	161	20.3	32.2	52.7	77.0	99.8	138	208	243	269	308	372	519	580	692	732	
KBM 184 P	184	23.2	36.8	60.2	88.0	114	158	238	278	307	352	425	593	663	790	836	
KBM 195 P	195	24.6	39.0	63.8	93.3	121	168	252	294	326	373	451	628	702	838	886	
KBM 208 P	208	26.2	41.6	68.1	99.5	129	179	269	314	347	398	481	670	749	893	945	
KBM 231 P	231	29.1	46.2	75.6	110	143	199	298	349	386	442	534	744	832	992	1050	
KBM 277 P	277	34.9	55.4	90.7	132	172	238	358	418	463	530	640	892	998	1190	1259	
KBM 310 P	310	39.1	62.0	101	148	192	267	401	468	518	593	716	999	1117	1332	1409	
KBM 323 P	323	40.7	64.6	106	154	200	278	417	487	540	618	746	1041	1164	1387	1468	
KBM 350 P	350	44.1	70.0	115	167	217	301	452	528	585	669	809	1128	1261	1503	1591	
KBM 369 P	369	46.5	73.8	121	176	229	317	477	557	616	706	853	1189	1329	1585	1677	
KBM 375 P	375	47.2	75.0	123	179	232	322	484	566	626	717	867	1208	1351	1611	1705	
KBM 400 P	400	50.4	80.0	130	191	248	344	517	604	668	765	924	1287	1441	1719	1816	
KBM 415 P	415	52.3	83.0	136	198	257	357	536	626	693	793	959	1337	1495	1783	1886	
KBM 438 P	438	55.2	87.6	143	209	272	377	566	661	732	837	1012	1411	1578	1881	1991	
KBM 461 P	461	58.1	92.2	151	220	286	396	596	696	770	881	1065	1485	1661	1980	2095	
KBM 480 P	480	60.5	96.0	157	230	298	413	620	724	802	918	1109	1546	1729	2062	2182	
KBM 495 P	495	62.4	99.0	162	237	307	426	640	747	827	946	1144	1595	1783	2126	2250	
KBM 540 P	540	68.0	108	177	258	335	464	698	815	902	1033	1248	1740	1945	2320	2455	
KBM 555 P	555	69.9	111	182	265	344	477	717	838	927	1061	1283	1788	1999	2384	2523	
KBM 590 P	590	74.3	118	193	282	366	507	762	890	986	1128	1364	1901	2125	2534	2682	
KBM 625 P	625	78.7	125	205	299	388	537	807	943	1044	1195	1444	2014	2251	2685	2841	
KBM 650 P	650	81.9	130	213	311	403	559	840	981	1086	1243	1502	2094	2341	2792	2955	
KBM 690 P	690	86.9	138	225	330	428	591	891	1041	1153	1320	1595	2220	2486	2966	3133	
KBM 705 P	705	88.8	141	231	337	437	606	911	1064	1178	1348	1629	2271	2540	3031	3201	
KBM 740 P	740	93.2	148	242	354	459	636	956	1117	1236	1415	1710	2384	2666	3181	3360	
KBM 770 P	770	97.0	154	252	368	477	662	995	1162	1286	1472	1780	2481	2774	3310	3496	
KBM 805 P	805	101	161	264	385	499	692	1040	1215	1345	1539	1860	2593	2900	3461	3655	
KBM 830 P	830	105	166	272	397	515	714	1072	1253	1387	1587	1918	2674	2990	3568	3769	
KBM 870 P	870	110	174	285	416	539	748	1124	1313	1453	1663	2011	2803	3134	3740	3950	
KBM 890 P	890	112	178	291	426	552	765	1150	1343	1487	1702	2057	2867	3206	3826	4041	
KBM 920 P	920	116	184	301	440	571	791	1189	1388	1537	1759	2126	2964	3314	3955	4177	
KBM 940 P	940	118	188	306	450	583	806	1214	1419	1572	1798	2172	3024	3386	4041	4268	
KBM 965 P	965	122	193	316	462	598	830	1247	1456	1612	1845	2230	3109	3476	4149	4382	
KBM 1000P	1000	126	200	327	478	620	860	1292	1509	1671	1912	2311	3222	3602	4299	4541	
KBM 1040P	1040	131	208	340	497	645	894	1344	1570	1737	1989	2403	3351	3746	4471	4722	
KBM 1100P	1100	139	220	360	526	682	946	1421	1660	1838	2103	2542	3544	3963	4729	4995	
KBM 1150P	1150	145	230	375	550	713	986	1486	1736	1921	2200	2657	3700	4143	4944	5222	
KBM 1180P	1180	149	236	386	564	732	1015	1525	1781	1971	2256	2727	3802	4251	5073	5358	
KBM 1225P	1225	154	245	399	586	760	1050	1583	1849	2048	2344	2830	3941	4413	5267	5562	
KBM 1270P	1270	160	254	416	607	787	1092	1641	1917	2122	2428	2934	4091	4575	5460	5767	
KBM 1330P	1330	168	266	435	636	825	1144	1718	2007	2222	2543	3074	4285	4791	5718	6039	
KBM 1390P	1390	175	278	455	665	862	1195	1796	2098	2322	2658	3212	4478	5007	5976	6312	
KBM 1460P	1460	184	292	476	698	905	1251	1886	2203	2439	2793	3374	4698	5260	6277	6629	

Cell Performance M range

Performance after long term floating with constant voltage charging

Final Voltage: 1.14 V/cell

Available amperes at +20° C ± 5° C

Cell Type	C _s Ah	Hours							Minutes					Seconds			
		8	5	3	2	1.5	1	30	20	15	10	5	60	30	5	1	
KBM 12 P	12	1.44	2.26	3.46	4.47	5.16	5.83	7.20	8.15	8.91	9.94	11.9	16.2	18.2	21.3	22.0	
KBM 16 P	16	1.92	3.01	4.61	5.96	6.88	7.77	9.60	10.9	11.9	13.3	15.9	21.7	24.3	28.4	29.3	
KBM 23 P	23	2.76	4.32	6.64	8.57	9.89	11.2	13.8	15.6	16.9	19.1	22.2	31.1	34.9	40.8	42.1	
KBM 26 P	26	3.12	4.89	7.51	9.69	11.2	12.6	15.6	17.7	19.1	21.5	25.1	35.2	39.5	46.1	47.6	
KBM 34 P	34	4.08	6.39	9.81	12.7	14.6	16.5	20.4	23.1	24.9	28.2	32.8	46.0	51.7	60.3	62.2	
KBM 44 P	44	5.28	8.27	12.7	16.4	18.9	21.4	26.4	29.9	32.3	36.4	42.4	59.6	66.8	78.0	80.5	
KBM 48 P	48	5.76	9.03	13.9	17.9	20.6	23.3	28.8	32.6	35.3	39.8	46.3	65.0	72.9	85.1	87.9	
KBM 57 P	57	6.84	10.7	16.5	21.6	25.3	29.1	35.9	40.4	43.4	48.4	56.5	78.7	87.6	101	104	
KBM 67 P	67	8.04	12.6	19.4	25.5	29.7	34.2	42.2	47.5	51.1	56.9	66.4	92.6	103	119	123	
KBM 75 P	75	9.00	14.1	21.7	28.4	33.2	38.3	47.2	53.1	57.2	63.7	74.3	104	115	133	137	
KBM 84 P	84	10.1	15.8	24.3	31.8	37.2	42.9	52.9	59.5	64.0	71.3	83.3	116	129	149	154	
KBM 95 P	95	11.4	17.9	27.5	36.0	42.1	48.5	59.7	67.3	72.4	80.6	94.2	131	146	168	174	
KBM 112 P	112	13.4	21.1	32.4	42.4	49.6	57.2	70.5	79.4	85.4	95.1	111	155	172	198	205	
KBM 138 P	138	16.6	25.9	39.9	52.3	61.1	70.4	86.8	97.8	105	117	137	191	212	244	253	
KBM 148 P	148	17.8	27.8	42.8	56.1	65.6	75.5	93.0	105	113	126	147	204	227	262	271	
KBM 161 P	161	19.3	30.3	46.6	61.0	71.3	82.2	101	114	123	137	160	222	247	285	295	
KBM 184 P	184	22.1	34.6	53.3	69.7	81.5	93.9	116	130	140	156	182	254	283	326	337	
KBM 195 P	195	23.4	36.7	56.4	73.9	86.4	99.5	123	138	149	165	193	269	300	345	357	
KBM 208 P	208	25.0	39.1	60.2	78.8	92.2	106	131	147	159	177	206	287	320	368	381	
KBM 231 P	231	27.7	43.4	66.9	87.5	102	118	146	164	176	196	229	319	355	409	423	
KBM 277 P	277	33.2	52.1	80.2	105	123	141	175	196	211	235	275	383	426	490	507	
KBM 310 P	310	37.2	58.3	89.7	117	137	158	195	220	236	263	307	428	476	549	567	
KBM 323 P	323	38.8	60.7	93.5	122	143	165	204	229	246	274	320	446	496	572	591	
KBM 350 P	350	42.0	65.8	101	133	155	179	221	248	267	297	347	484	538	619	641	
KBM 369 P	369	44.3	69.4	107	140	163	188	233	261	281	313	366	510	567	653	675	
KBM 375 P	375	45.0	70.5	109	142	166	191	236	266	286	318	372	518	576	664	686	
KBM 400 P	400	48.0	75.2	116	152	177	204	252	283	305	339	396	553	615	707	732	
KBM 415 P	415	49.8	78.0	120	157	183	212	262	294	316	352	411	573	638	734	760	
KBM 438 P	438	52.6	82.3	127	166	193	224	276	310	334	372	434	605	673	775	802	
KBM 461 P	461	55.3	86.7	133	175	204	235	291	327	351	391	457	637	708	816	844	
KBM 480 P	480	57.6	90.2	139	182	213	245	303	340	366	407	476	663	738	849	879	
KBM 495 P	495	59.4	93.1	143	188	219	253	312	351	377	420	491	684	761	876	906	
KBM 540 P	540	64.8	102	156	205	239	276	340	383	412	458	535	746	830	956	989	
KBM 555 P	555	66.6	104	161	210	245	283	350	393	423	471	550	767	853	982	1016	
KBM 590 P	590	70.8	111	171	224	261	301	372	418	450	501	585	815	907	1044	1080	
KBM 625 P	625	75.0	118	181	237	276	319	394	443	476	530	619	863	960	1106	1144	
KBM 650 P	650	78.0	122	188	246	288	332	410	461	495	552	644	898	999	1150	1190	
KBM 690 P	690	82.8	130	200	262	306	352	435	489	526	586	684	953	1059	1220	1264	
KBM 705 P	705	84.6	133	204	267	312	360	444	500	537	598	699	974	1083	1248	1291	
KBM 740 P	740	88.8	139	214	280	327	378	466	524	564	628	733	1022	1137	1310	1355	
KBM 770 P	770	92.4	145	223	292	341	393	485	546	587	654	763	1064	1183	1363	1410	
KBM 805 P	805	96.6	151	233	305	357	411	507	570	614	683	798	1112	1237	1425	1474	
KBM 830 P	830	99.6	156	240	315	367	424	523	588	633	704	823	1147	1275	1469	1519	
KBM 870 P	870	104	164	252	330	385	444	548	616	663	738	862	1202	1337	1540	1593	
KBM 890 P	890	107	167	258	337	394	454	561	631	678	755	882	1229	1368	1575	1629	
KBM 920 P	920	110	173	266	349	407	469	580	652	701	781	912	1271	1414	1628	1684	
KBM 940 P	940	113	177	273	356	416	480	592	666	716	798	932	1299	1443	1662	1721	
KBM 965 P	965	116	181	279	366	427	493	608	684	735	819	956	1333	1483	1708	1767	
KBM 1000P	1000	120	188	289	379	443	510	630	709	762	849	991	1381	1537	1770	1831	
KBM 1040P	1040	125	196	301	394	460	531	655	737	793	883	1031	1437	1598	1840	1904	
KBM 1100P	1100	132	207	318	417	487	561	693	779	838	934	1090	1520	1690	1947	2014	
KBM 1150P	1150	138	216	334	436	510	587	724	815	876	975	1140	1589	1766	2034	2106	
KBM 1180P	1180	142	222	342	447	523	602	744	836	899	1001	1170	1630	1813	2088	2160	
KBM 1225P	1225	147	230	356	464	543	626	771	868	934	1040	1213	1692	1881	2167	2243	
KBM 1270P	1270	152	239	368	481	563	648	800	900	968	1078	1259	1754	1952	2247	2325	
KBM 1330P	1330	160	250	385	504	589	679	838	942	1014	1129	1318	1837	2044	2354	2435	
KBM 1390P	1390	167	261	402	527	615	709	876	984	1059	1180	1378	1920	2136	2460	2545	
KBM 1460P	1460	175	275	423	553	647	745	918	1034	1113	1239	1446	2017	2242	2582	2673	

Cell Performance **M** range

Performance after long term floating with constant voltage charging

Final Voltage: 1.10 V/cell

Available amperes at +20° C ± 5° C

Cell Type	C _s Ah	Hours						Minutes					Seconds			
		8	5	3	2	1.5	1	30	20	15	10	5	60	30	5	1
KBM 12 P	12	1.48	2.34	3.74	5.10	6.10	7.30	9.03	10.2	11.0	12.2	14.4	20.1	22.7	28.8	31.4
KBM 16 P	16	1.97	3.12	4.99	6.80	8.13	9.73	12.0	13.6	14.6	16.3	19.2	26.8	30.3	38.3	41.9
KBM 23 P	23	2.83	4.49	7.18	9.79	11.7	14.0	17.3	19.5	21.0	23.4	27.5	38.5	43.6	55.1	60.2
KBM 26 P	26	3.20	5.07	8.11	11.0	13.2	15.8	19.6	22.1	23.8	26.5	31.1	43.6	49.3	62.3	68.1
KBM 34 P	34	4.18	6.63	10.6	14.4	17.3	20.7	25.6	28.9	31.0	34.7	40.7	57.0	64.4	81.5	89.0
KBM 44 P	44	5.41	8.58	13.7	18.7	22.4	26.8	33.1	37.4	40.2	44.9	52.7	73.7	83.4	105	115
KBM 48 P	48	5.90	9.36	15.0	20.5	24.4	29.2	36.1	40.8	43.9	48.9	57.5	80.4	91.0	115	126
KBM 57 P	57	7.01	11.1	18.0	24.5	29.6	36.4	44.8	50.6	54.3	60.6	70.3	96.6	108	127	135
KBM 67 P	67	8.24	13.1	21.1	28.8	34.8	42.7	52.6	59.5	63.8	71.2	82.7	114	127	150	159
KBM 75 P	75	9.23	14.6	23.6	32.2	38.9	47.8	58.9	66.6	71.4	79.8	92.6	127	142	168	178
KBM 84 P	84	10.3	16.4	26.5	36.1	43.6	53.6	66.0	74.5	80.0	89.3	104	142	159	188	199
KBM 95 P	95	11.7	18.5	29.9	40.8	49.3	60.6	74.6	84.3	90.4	101	117	161	180	212	225
KBM 112 P	112	13.8	21.8	35.3	48.1	58.1	71.4	87.9	99.4	107	119	138	190	212	250	265
KBM 138 P	138	17.0	26.9	43.5	59.2	71.6	88.0	108	122	131	147	170	234	261	308	327
KBM 148 P	148	18.2	28.9	46.6	63.5	76.8	94.4	116	131	141	157	183	251	280	331	351
KBM 161 P	161	19.8	31.4	50.7	69.1	83.5	103	126	143	153	171	199	273	305	360	382
KBM 184 P	184	22.6	35.9	58.0	79.0	95.5	117	144	163	175	196	227	312	348	411	436
KBM 195 P	195	24.0	38.0	61.4	83.7	101	124	153	173	186	207	241	331	369	436	462
KBM 208 P	208	25.6	40.6	65.5	89.3	108	133	163	185	198	221	257	353	394	465	493
KBM 231 P	231	28.4	45.0	72.8	99.2	120	147	181	205	220	246	285	392	437	516	547
KBM 277 P	277	34.1	54.0	87.3	119	144	177	217	246	264	295	342	470	524	619	657
KBM 310 P	310	38.1	60.5	97.7	133	161	198	243	275	295	330	383	526	587	693	735
KBM 323 P	323	39.7	63.0	102	139	168	206	254	287	308	343	399	548	611	722	766
KBM 350 P	350	43.1	68.3	110	150	182	223	275	311	333	372	432	593	663	782	830
KBM 369 P	369	45.4	72.0	116	158	191	235	290	327	351	392	455	626	699	825	875
KBM 375 P	375	46.1	73.1	118	161	195	239	294	333	357	399	463	636	710	838	889
KBM 400 P	400	49.2	78.0	126	172	208	255	314	355	381	425	494	679	757	894	947
KBM 415 P	415	51.0	80.9	131	178	215	265	326	368	395	441	512	704	786	928	984
KBM 438 P	438	53.9	85.4	138	188	227	279	344	389	417	466	541	743	829	979	1038
KBM 461 P	461	56.7	89.9	145	198	239	294	362	409	439	490	569	782	873	1030	1093
KBM 480 P	480	59.0	93.6	151	206	249	306	377	426	457	510	592	814	909	1073	1138
KBM 495 P	495	60.9	96.5	156	213	257	316	389	439	471	526	611	840	937	1106	1173
KBM 540 P	540	66.4	105	170	232	280	344	424	479	514	574	666	916	1022	1207	1280
KBM 555 P	555	68.3	108	175	238	288	354	436	492	528	590	685	941	1051	1241	1315
KBM 590 P	590	72.6	115	186	253	306	376	463	524	562	627	728	1000	1117	1319	1398
KBM 625 P	625	76.9	122	197	268	324	399	491	555	595	665	771	1060	1183	1397	1481
KBM 650 P	650	80.0	127	205	279	337	415	510	577	619	691	802	1102	1231	1453	1541
KBM 690 P	690	84.9	135	217	296	358	440	542	613	657	734	851	1170	1306	1542	1633
KBM 705 P	705	86.7	137	222	303	366	450	553	626	671	750	870	1195	1335	1576	1671
KBM 740 P	740	91.0	144	233	318	384	472	581	657	705	787	913	1255	1401	1654	1754
KBM 770 P	770	94.7	150	243	331	400	491	605	683	733	819	950	1305	1458	1721	1825
KBM 805 P	805	99.0	157	254	346	418	513	632	714	766	856	993	1365	1524	1799	1908
KBM 830 P	830	102	162	261	356	431	529	652	737	790	883	1024	1408	1571	1855	1967
KBM 870 P	870	107	170	274	374	451	555	683	772	828	925	1074	1475	1647	1945	2062
KBM 890 P	890	109	174	280	382	462	568	699	790	847	946	1098	1509	1685	1989	2109
KBM 920 P	920	113	179	290	395	477	587	722	817	876	978	1135	1561	1742	2056	2180
KBM 940 P	940	116	183	296	404	488	600	738	834	895	1000	1159	1594	1780	2101	2225
KBM 965 P	965	119	188	304	414	501	616	758	857	919	1026	1191	1637	1827	2157	2287
KBM 1000P	1000	123	195	315	429	519	638	785	887	952	1063	1234	1695	1893	2235	2370
KBM 1040P	1040	128	203	328	447	540	663	816	923	990	1106	1283	1764	1969	2325	2465
KBM 1100P	1100	135	215	347	472	571	702	864	976	1047	1170	1357	1865	2082	2459	2607
KBM 1150P	1150	141	224	362	494	597	734	903	1020	1095	1223	1419	1950	2177	2571	2722
KBM 1180P	1180	145	230	372	507	612	753	926	1047	1123	1255	1456	2001	2234	2638	2797
KBM 1225P	1225	151	239	386	526	636	781	962	1087	1166	1303	1512	2077	2319	2738	2899
KBM 1270P	1270	156	248	400	545	659	810	997	1127	1209	1351	1567	2153	2404	2839	3010
KBM 1330P	1330	164	259	419	571	690	848	1044	1180	1266	1414	1641	2255	2518	2973	3152
KBM 1390P	1390	171	271	438	597	721	887	1091	1235	1323	1478	1715	2358	2631	3107	3294
KBM 1460P	1460	180	285	460	627	758	931	1146	1296	1390	1553	1801	2475	2764	3263	3456

Cell Performance M range

Performance after long term floating with constant voltage charging

Final Voltage: 1.05 V/cell

Available amperes at +20° C ± 5° C

Cell Type	C _s Ah	Hours						Minutes					Seconds			
		8	5	3	2	1.5	1	30	20	15	10	5	60	30	5	1
KBM 12 P	12	1.50	2.38	3.86	5.61	6.91	8.78	11.1	12.5	13.6	15.2	17.9	25.0	28.0	33.3	36.0
KBM 16 P	16	2.00	3.17	5.15	7.48	9.21	11.7	14.8	16.6	18.1	20.3	23.9	33.3	37.4	44.4	48.0
KBM 23 P	23	2.88	4.56	7.40	10.7	13.2	16.8	21.3	23.9	26.1	29.2	34.4	47.9	53.7	63.9	69.0
KBM 26 P	26	3.25	5.15	8.37	12.1	15.0	19.0	24.1	27.0	29.5	33.0	38.8	54.2	60.7	72.2	78.0
KBM 34 P	34	4.25	6.73	10.9	15.9	19.6	24.9	31.5	35.3	38.5	43.2	50.8	70.8	79.4	94.4	102
KBM 44 P	44	5.50	8.71	14.2	20.6	25.3	32.2	40.9	45.7	49.9	55.9	65.7	91.7	103	122	132
KBM 48 P	48	6.00	9.51	15.5	22.4	27.6	35.1	44.4	49.8	54.4	60.9	71.7	100	112	131	140
KBM 57 P	57	7.13	11.3	18.4	26.7	33.3	43.2	55.7	62.6	67.9	75.4	87.7	120	135	159	171
KBM 67 P	67	8.38	13.3	21.6	31.3	39.1	50.8	65.5	73.6	79.8	88.6	103	141	158	187	201
KBM 75 P	75	9.38	14.8	24.2	35.1	43.8	56.9	73.3	82.4	89.3	99.2	115	158	177	209	225
KBM 84 P	84	10.5	16.6	27.1	39.3	49.0	63.7	82.1	92.3	100	111	129	176	199	234	252
KBM 95 P	95	11.9	18.8	30.7	44.4	55.4	72.0	92.8	104	113	126	146	200	225	265	285
KBM 112 P	112	14.0	22.2	36.2	52.4	65.4	84.9	109	123	133	148	172	235	265	312	336
KBM 138 P	138	17.3	27.3	44.6	64.6	80.5	105	135	152	164	183	212	290	326	384	414
KBM 148 P	148	18.5	29.2	47.8	69.2	86.4	112	145	163	176	196	228	311	350	412	444
KBM 161 P	161	20.1	31.9	52.0	75.3	94.0	122	157	177	192	213	248	338	381	448	484
KBM 184 P	184	23.0	36.4	59.5	86.1	107	140	180	202	219	243	283	387	435	513	553
KBM 195 P	195	24.4	38.5	63.0	91.2	114	148	191	214	232	258	300	410	461	543	586
KBM 208 P	208	26.0	41.2	67.2	97.3	121	158	203	228	248	275	320	437	492	579	625
KBM 231 P	231	28.9	45.7	74.6	108	135	175	226	254	275	306	356	485	546	643	694
KBM 277 P	277	34.6	54.9	89.5	130	162	210	271	304	330	366	426	582	655	772	832
KBM 310 P	310	38.8	61.4	100	145	181	235	303	341	369	410	477	651	733	864	931
KBM 323 P	323	40.4	64.0	104	151	189	245	316	355	385	427	497	679	764	900	970
KBM 350 P	350	43.8	69.3	113	164	204	265	342	384	417	463	539	735	828	975	1051
KBM 369 P	369	46.1	73.1	119	173	215	280	361	405	439	488	568	775	872	1028	1108
KBM 375 P	375	46.9	74.1	121	175	219	284	366	412	447	496	577	788	887	1045	1126
KBM 400 P	400	50.0	78.8	129	187	233	303	391	440	476	528	616	840	946	1112	1200
KBM 415 P	415	51.9	82.2	134	194	242	315	405	456	494	549	639	872	981	1156	1246
KBM 438 P	438	54.8	86.7	142	205	256	332	428	481	522	579	674	920	1036	1220	1315
KBM 461 P	461	57.6	91.5	149	216	269	350	450	506	549	610	710	968	1090	1284	1384
KBM 480 P	480	60.0	94.9	155	225	280	364	469	527	572	635	739	1008	1135	1337	1442
KBM 495 P	495	61.9	98.2	160	232	289	375	484	544	589	655	762	1040	1170	1379	1487
KBM 540 P	540	67.5	107	174	253	315	409	528	593	643	714	831	1134	1277	1504	1622
KBM 555 P	555	69.4	110	179	260	324	421	542	610	661	734	854	1166	1312	1546	1667
KBM 590 P	590	73.8	117	191	276	344	447	576	648	703	780	908	1239	1395	1643	1772
KBM 625 P	625	78.1	124	202	292	365	474	611	687	744	827	962	1313	1478	1741	1877
KBM 650 P	650	81.3	128	210	304	379	493	635	714	774	860	1001	1366	1537	1811	1952
KBM 690 P	690	86.3	136	223	323	403	523	674	759	821	912	1062	1450	1630	1920	2070
KBM 705 P	705	88.1	139	228	330	411	535	689	774	840	932	1085	1481	1667	1964	2117
KBM 740 P	740	92.5	147	239	346	432	561	723	813	881	979	1139	1555	1750	2061	2222
KBM 770 P	770	96.3	152	249	360	449	584	752	846	917	1018	1185	1618	1821	2145	2312
KBM 805 P	805	101	159	260	377	470	610	786	884	959	1065	1239	1691	1903	2242	2418
KBM 830 P	830	104	164	268	388	484	630	811	912	988	1098	1278	1744	1962	2312	2493
KBM 870 P	870	109	172	281	407	508	660	850	956	1036	1151	1339	1828	2057	2423	2613
KBM 890 P	890	111	176	288	416	519	675	870	978	1060	1177	1370	1870	2104	2479	2673
KBM 920 P	920	115	182	297	431	537	698	899	1011	1096	1217	1416	1933	2175	2563	2763
KBM 940 P	940	118	185	304	440	549	713	918	1034	1119	1240	1446	1975	2220	2615	2820
KBM 965 P	965	121	191	312	452	563	732	943	1060	1149	1273	1484	2027	2280	2684	2895
KBM 1000P	1000	125	198	323	468	584	758	977	1098	1191	1320	1538	2101	2362	2781	3000
KBM 1040P	1040	130	206	336	487	607	789	1017	1142	1239	1372	1600	2185	2457	2893	3120
KBM 1100P	1100	138	217	355	514	642	834	1075	1208	1310	1452	1692	2311	2598	3060	3300
KBM 1150P	1150	144	227	372	538	671	872	1123	1265	1369	1518	1769	2416	2717	3199	3450
KBM 1180P	1180	148	233	381	552	689	895	1153	1296	1405	1557	1815	2479	2787	3282	3540
KBM 1225P	1225	153	241	396	573	715	929	1197	1347	1458	1616	1884	2574	2894	3407	3675
KBM 1270P	1270	159	251	410	594	741	963	1241	1395	1512	1676	1953	2668	3000	3532	3810
KBM 1330P	1330	166	263	430	622	776	1008	1299	1461	1584	1755	2046	2794	3142	3699	3990
KBM 1390P	1390	174	275	449	650	811	1055	1358	1527	1656	1834	2138	2920	3283	3866	4170

Cell Performance M range

Performance after long term floating with constant voltage charging

Final Voltage: 1.00 V/cell

Available amperes at +20° C ± 5° C

Cell Type	C _s Ah	Hours							Minutes					Seconds			
		8	5	3	2	1.5	1	30	20	15	10	5	60	30	5	1	
KBM 12 P	12	1.51	2.40	3.92	5.73	7.42	9.74	13.0	14.8	16.0	17.9	21.4	30.2	34.3	41.0	43.4	
KBM 16 P	16	2.02	3.20	5.23	7.63	9.89	13.0	17.4	19.8	21.4	23.9	28.5	40.3	45.7	54.7	57.9	
KBM 23 P	23	2.90	4.60	7.52	11.0	14.2	18.7	25.0	28.4	30.8	34.4	41.0	57.9	65.7	78.6	83.3	
KBM 26 P	26	3.28	5.20	8.50	12.4	16.1	21.1	28.2	32.1	34.8	38.9	46.3	65.5	74.3	88.9	94.1	
KBM 34 P	34	4.28	6.80	11.1	16.2	21.0	27.6	36.9	42.0	45.5	50.8	60.6	85.5	97.1	116	123	
KBM 44 P	44	5.54	8.80	14.4	21.0	27.2	35.7	47.8	54.3	58.8	65.8	78.4	111	126	150	159	
KBM 48 P	48	6.05	9.60	15.7	22.9	29.7	39.0	52.1	59.3	64.2	71.7	85.5	121	137	164	174	
KBM 57 P	57	7.18	11.4	18.7	27.3	35.3	46.8	65.5	74.2	80.5	89.9	106	147	164	196	207	
KBM 67 P	67	8.44	13.4	21.9	32.0	41.5	55.0	77.0	87.2	94.6	106	125	173	193	230	244	
KBM 75 P	75	9.45	15.0	24.5	35.9	46.5	61.6	86.2	97.6	106	118	140	193	216	258	273	
KBM 84 P	84	10.6	16.8	27.5	40.2	52.1	69.0	96.6	109	119	133	157	216	242	289	305	
KBM 95 P	95	12.0	19.0	31.1	45.4	58.9	78.0	109	124	134	150	177	245	274	326	345	
KBM 112 P	112	14.1	22.4	36.7	53.6	69.4	92.0	129	146	158	177	209	289	323	385	407	
KBM 138 P	138	17.4	27.6	45.2	66.0	85.6	113	159	180	195	218	257	356	398	474	502	
KBM 148 P	148	18.6	29.6	48.4	70.8	91.8	122	170	193	209	233	276	381	427	509	538	
KBM 161 P	161	20.3	32.2	52.7	77.0	99.8	132	185	209	227	254	300	415	464	553	585	
KBM 184 P	184	23.2	36.8	60.2	88.0	114	151	212	239	260	290	343	474	530	632	669	
KBM 195 P	195	24.6	39.0	63.8	93.3	121	160	224	254	275	308	364	503	562	670	709	
KBM 208 P	208	26.2	41.6	68.1	99.5	129	171	239	271	294	328	388	536	599	715	756	
KBM 231 P	231	29.1	46.2	75.6	110	143	190	266	301	326	364	431	595	666	794	840	
KBM 277 P	277	34.9	55.4	90.7	132	172	227	319	360	391	437	517	714	798	952	1007	
KBM 310 P	310	39.1	62.0	101	148	192	255	356	403	438	489	578	799	893	1065	1127	
KBM 323 P	323	40.7	64.6	106	154	200	265	371	420	456	510	602	832	931	1110	1175	
KBM 350 P	350	44.1	70.0	115	167	217	287	402	455	494	552	653	902	1009	1203	1273	
KBM 369 P	369	46.5	73.8	121	176	229	303	424	480	521	582	688	951	1063	1268	1342	
KBM 375 P	375	47.2	75.0	123	179	232	308	431	488	529	592	699	966	1081	1289	1364	
KBM 400 P	400	50.4	80.0	130	191	248	328	460	520	565	631	746	1030	1153	1375	1453	
KBM 415 P	415	52.3	83.0	136	198	257	341	477	540	586	655	774	1070	1196	1426	1509	
KBM 438 P	438	55.2	87.6	143	209	272	360	504	570	618	691	817	1129	1262	1505	1593	
KBM 461 P	461	58.1	92.2	151	220	286	379	530	600	651	727	860	1188	1329	1584	1676	
KBM 480 P	480	60.5	96.0	157	230	298	394	552	624	678	757	895	1237	1383	1649	1745	
KBM 495 P	495	62.4	99.0	162	237	307	406	569	644	699	781	923	1276	1427	1701	1800	
KBM 540 P	540	68.0	108	177	258	335	443	621	703	762	852	1007	1392	1556	1856	1964	
KBM 555 P	555	69.9	111	182	265	344	456	638	722	783	875	1035	1430	1599	1907	2018	
KBM 590 P	590	74.3	118	193	282	366	484	678	768	833	931	1100	1521	1700	2027	2145	
KBM 625 P	625	78.7	125	205	299	388	513	719	813	882	986	1166	1611	1801	2148	2273	
KBM 650 P	650	81.9	130	213	311	403	534	747	846	918	1025	1212	1675	1873	2234	2364	
KBM 690 P	690	86.9	138	225	330	428	565	793	898	974	1089	1287	1776	1988	2373	2506	
KBM 705 P	705	88.8	141	231	337	437	579	811	917	995	1112	1315	1817	2032	2425	2561	
KBM 740 P	740	93.2	148	242	354	459	608	851	963	1045	1167	1380	1907	2133	2545	2688	
KBM 770 P	770	97.0	154	252	368	477	632	885	1002	1087	1215	1436	1985	2219	2648	2797	
KBM 805 P	805	101	161	264	385	499	661	926	1047	1136	1270	1501	2075	2320	2769	2924	
KBM 830 P	830	105	166	272	397	515	682	954	1080	1172	1309	1548	2139	2392	2855	3015	
KBM 870 P	870	110	174	285	416	539	714	1000	1132	1228	1372	1623	2242	2507	2992	3160	
KBM 890 P	890	112	178	291	426	552	731	1023	1158	1256	1404	1660	2294	2565	3061	3233	
KBM 920 P	920	116	184	301	440	571	755	1058	1197	1299	1451	1716	2371	2651	3164	3342	
KBM 940 P	940	118	188	306	450	583	770	1081	1223	1328	1484	1753	2420	2709	3233	3415	
KBM 965 P	965	122	193	316	462	598	792	1110	1255	1362	1522	1800	2487	2781	3319	3505	
KBM 1000P	1000	126	200	327	478	620	821	1150	1301	1412	1577	1865	2577	2882	3439	3633	
KBM 1040P	1040	131	208	340	497	645	854	1196	1353	1468	1641	1939	2680	2997	3577	3778	
KBM 1100P	1100	139	220	360	526	682	903	1265	1431	1553	1735	2052	2835	3170	3783	3996	
KBM 1150P	1150	145	230	375	550	713	942	1322	1496	1623	1815	2144	2960	3314	3955	4177	
KBM 1180P	1180	149	236	386	564	732	969	1357	1535	1666	1861	2201	3041	3401	4058	4286	
KBM 1225P	1225	154	245	399	586	760	1002	1409	1594	1731	1933	2284	3153	3530	4213	4450	
KBM 1270P	1270	160	254	416	607	787	1043	1460	1652	1793	2003	2368	3273	3660	4368	4613	
KBM 1330P	1330	168	266	435	636	825	1092	1529	1730	1877	2098	2480	3428	3833	4574	4831	
KBM 1390P	1390	175	278	455	665	862	1141	1598	1808	1962	2193	2592	3582	4006	4781	5049	

L Range

Cell dimensions

Cell Type	Capacity at the 5 hr rate (Ah)	Cell Dimensions in mm						Cell connection bolt size	Container size reference	Reserve electrolyte cc/cell	Approx Weight(Kg) 1.2 V Block
		Height	Width	Length							
				1.2 V L (1)	2.4 V L (2)	3.6 V L (3)					
KBL 8 P	8	264	123		79	115	M8	B22-1	110	0.9	
KBL 17 P	17	264	123		79	115	M8	B22-1	110	1.2	
KBL 21 P	21	264	123		79	115	M8	B22-1	110	1.4	
KBL 32 P	32	264	123		103	151	M8	B23-1	145	2.0	
KBL 38 P	38	264	123		103	151	M8	B23-1	145	2.4	
KBL 46 P	46	264	123		127	187	M8	B24-1	185	3.4	
KBL 50 P	50	405	195		79	115	M10	B45-1	280	4.0	
KBL 64 P	64	405	195		79	115	M10	B45-1	280	4.5	
KBL 73 P	73	405	195		79	115	M10	B45-1	280	4.8	
KBL 80 P	80	405	195		79	115	M10	B45-1	280	5.1	
KBL 90 P	90	405	195		79	115	M10	B45-1	280	5.4	
KBL 102 P	102	349	195		103	151	M10	B33-1	380	5.7	
KBL 118 P	118	405	195		115	169	M10	B42A-1	450	7.3	
KBL 128 P	128	349	195		127	187	M10	B32-1	515	7.3	
KBL 140 P	140	405	195		115	169	M10	B42A-1	450	7.8	
KBL 155 P	155	405	195		127	187	M10	B42-1	515	8.2	
KBL 173 P	173	405	195		127	187	M10	B42-1	515	8.5	
KBL 200 P	200	405	195		159	232	M10	B41B-1	650	10.5	
KBL 214 P	214	405	195		159	232	M10	B41B-1	650	10.7	
KBL 220 P	220	405	195		183	268	M10	B41-1	745	11.2	
KBL 256 P	256	405	195		183	268	M10	B41-1	745	12.7	
KBL 280 P	280	405	195	120	228	336	2 x M10	B42A-2	900	15.6	
KBL 304 P	304	405	195	120	228	336	2 x M10	B42A-2	900	15.9	
KBL 320 P	320	405	195	132	252	372	2 x M10	B42-2	1030	16.5	
KBL 346 P	346	405	195	132	252	372	2 x M10	B42-2	1030	16.7	
KBL 360 P	360	405	195	159	304		2 x M10	B41B-2	1300	19.8	
KBL 390 P	390	405	195	159	304		2 x M10	B41B-2	1300	20.2	
KBL 400 P	400	405	195	159	304		2 x M10	B41B-2	1300	20.8	
KBL 429 P	429	405	195	159	304		2 x M10	B41B-2	1300	21.2	
KBL 450 P	450	405	195	183	352		2 x M10	B41-2	1490	23.5	
KBL 465 P	465	405	195	183	352		2 x M10	B41-2	1490	24.2	
KBL 490 P	490	405	195	183			2 x M10	B41-2	1490	24.9	
KBL 510 P	510	405	195	183			2 x M10	B41-2	1490	25.2	
KBL 535 P	535	405	195	232			3 x M10	B41B-3	1950	27.4	
KBL 570 P	570	405	195	232			3 x M10	B41B-3	1950	28.8	
KBL 585 P	585	405	195	232			3 x M10	B41B-3	1950	30.2	
KBL 620 P	620	405	195	232			3 x M10	B41B-3	1950	31.0	
KBL 645 P	645	405	195	232			3 x M10	B41B-3	1950	31.6	
KBL 675 P	675	405	195	268			3 x M10	B41-3	2235	35.6	
KBL 700 P	700	405	195	268			3 x M10	B41-3	2235	36.1	
KBL 770 P	770	405	195	268			3 x M10	B41-3	2235	38.2	
KBL 800 P	800	405	195	304			4 x M10	B41B-4	2600	41.8	
KBL 830 P	830	405	195	304			4 x M10	B41B-4	2600	42.5	
KBL 860 P	860	405	195	304			4 x M10	B41B-4	2600	42.8	
KBL 920 P	920	405	195	352			4 x M10	B41-4	2980	48.0	
KBL 970 P	970	405	195	352			4 x M10	B41-4	2980	49.2	
KBL 1020 P	1020	405	195	352			4 x M10	B41-4	2980	50.8	
KBL 1040 P	1040	405	195	377			5 x M10	B41B-5	3250	52.4	
KBL 1070 P	1070	405	195	377			5 x M10	B41B-5	3250	53.5	
KBL 1140 P	1140	405	195	437			5 x M10	B41-5	3725	59.0	
KBL 1220 P	1220	405	195	437			5 x M10	B41-5	3725	61.3	
KBL 1240 P	1240	405	195	437			5 x M10	B41-5	3725	61.8	
KBL 1280 P	1280	405	195	437			5 x M10	B41-5	3725	63.5	
KBL 1320 P	1320	405	195	522			6 x M10	B41-6	4470	70.0	
KBL 1360 P	1360	405	195	522			6 x M10	B41-6	4470	71.1	
KBL 1400 P	1400	405	195	522			6 x M10	B41-6	4470	72.0	
KBL 1480 P	1480	405	195	522			6 x M10	B41-6	4470	74.0	
KBL 1540 P	1540	405	195	522			6 x M10	B41-6	4470	75.0	

- ✓ Block types starting from KBL 200 P shall have handles.
- ✓ Cell ranges other than listed above can be supplied on request. The Parameters and performance will proportionately change.

Cell Performance **L** range
 Performance fully charged with constant current charging

Available amperes at +20° C ± 5° C

Final Voltage: 1.14 V/cell

Cell Type	C _s Ah	Hours								Minutes					Seconds			
		10	8	5	3	2	1.5	1	30	20	15	10	5	60	30	5	1	
KBL 8 P	8	0.79	0.97	1.51	2.37	3.04	3.49	4.06	5.12	5.76	6.20	6.96	8.16	10.7	11.4	12.2	13.6	
KBL 17 P	17	1.66	2.06	3.21	5.04	6.52	7.48	8.67	10.9	12.2	13.2	14.7	17.0	22.3	23.9	25.8	28.9	
KBL 21 P	21	2.05	2.54	3.96	6.23	8.06	9.24	10.7	13.4	15.1	16.3	18.1	21.0	27.6	29.5	31.9	35.7	
KBL 32 P	32	3.13	3.87	6.04	9.50	12.2	14.0	16.2	20.4	22.9	24.8	27.4	31.7	42.1	45.0	48.6	54.5	
KBL 38 P	38	3.72	4.59	7.17	11.3	14.4	16.6	19.3	24.3	27.1	29.5	32.5	37.6	50.0	53.4	57.8	64.7	
KBL 46 P	46	4.50	5.56	8.68	13.6	17.5	20.1	23.4	29.4	32.9	35.7	39.3	45.5	60.5	64.7	69.9	78.4	
KBL 50 P	50	4.89	6.03	9.43	14.9	19.0	21.7	25.5	31.5	35.6	38.0	42.0	49.0	63.6	69.1	74.0	75.0	
KBL 64 P	64	6.26	7.72	12.1	19.0	24.3	27.8	32.5	40.3	45.4	48.5	53.6	62.7	81.4	88.4	94.7	96.0	
KBL 73 P	73	7.14	8.81	13.8	21.7	27.8	31.7	37.2	46.0	52.0	55.5	61.3	71.7	92.9	101	108	110	
KBL 80 P	80	7.82	9.65	15.1	23.7	30.4	34.8	40.8	50.4	56.7	60.8	67.1	78.4	102	110	118	120	
KBL 90 P	90	8.81	10.9	17.0	26.7	34.2	39.1	45.9	56.7	63.9	68	75.6	88.2	114	124	133	135	
KBL 102 P	102	9.99	12.3	19.3	30.3	39.2	44.9	52.0	65.3	73.4	77.5	87.7	102	134	144	155	174	
KBL 118 P	118	11.5	14.2	22.3	35.0	44.8	51.3	60.2	74.3	83.7	90	98.9	116	150	163	175	177	
KBL 128 P	128	12.5	15.5	24.2	38.0	49.1	56.4	65.3	81.9	92.1	97	110	128	168	180	195	218	
KBL 140 P	140	13.7	16.9	26.4	41.5	53.2	60.9	71.4	88.2	99.5	106	117	137	178	193	207	210	
KBL 155 P	155	15.2	18.7	29.2	46.0	58.9	67.4	79.1	97.5	110	118	130	152	197	214	229	232	
KBL 173 P	173	16.9	20.9	32.7	51.4	65.7	75.2	88.2	109	123	131	145	170	220	239	256	259	
KBL 200 P	200	19.6	24.1	37.7	59.3	76.0	87.0	102	126	142	152	168	196	254	276	296	300	
KBL 214 P	214	20.9	25.8	40.4	63.6	81.3	93.1	109	135	152	163	180	210	272	295	317	321	
KBL 220 P	220	21.5	26.6	41.5	65.3	83.5	95.8	112	139	156	167	184	216	280	304	326	331	
KBL 256 P	256	25.1	30.9	48.3	76.0	97.3	111	130	161	182	195	215	251	325	353	379	384	
KBL 280 P	280	27.4	33.8	52.8	83.1	106	122	143	176	199	213	235	275	356	387	414	420	
KBL 304 P	304	29.8	36.7	57.4	90.3	116	132	155	191	216	231	255	298	387	419	450	456	
KBL 320 P	320	31.3	38.6	60.4	95.0	122	139	163	201	227	243	268	314	407	442	473	480	
KBL 346 P	346	33.9	41.7	65.3	103	131	150	176	218	246	263	291	339	440	477	512	519	
KBL 360 P	360	35.2	43.4	67.9	107	137	157	184	226	255	274	302	353	458	497	533	540	
KBL 390 P	390	38.2	47.0	73.6	116	148	170	199	246	278	296	327	382	496	538	577	585	
KBL 400 P	400	39.1	48.3	75.5	119	152	174	204	252	284	304	335	392	509	552	592	600	
KBL 429 P	429	42.0	51.7	81.0	127	163	187	219	270	305	326	360	421	545	592	635	643	
KBL 450 P	450	44.0	54.3	84.9	134	171	196	230	283	319	342	377	441	572	622	666	675	
KBL 465 P	465	45.5	56.1	87.7	138	177	202	237	292	330	353	390	456	591	642	688	697	
KBL 490 P	490	47.9	59.1	92.5	145	186	213	250	308	348	372	411	480	623	677	725	735	
KBL 510 P	510	49.9	61.5	96.3	151	194	222	260	321	362	388	428	500	648	704	754	765	
KBL 535 P	535	52.3	64.5	101	159	203	233	273	336	379	407	448	525	680	739	791	802	
KBL 570 P	570	55.7	68.8	108	169	217	248	291	358	404	433	478	559	725	787	843	855	
KBL 585 P	585	57.2	70.6	110	174	222	254	298	368	415	445	491	574	744	807	865	877	
KBL 620 P	620	60.6	74.8	117	184	236	270	316	390	440	471	520	608	788	856	917	930	
KBL 645 P	645	63.1	77.8	122	192	245	280	329	406	458	490	542	632	820	890	954	967	
KBL 675 P	675	66.0	81.4	127	200	256	293	344	425	479	513	566	662	858	932	999	1012	
KBL 700 P	700	68.4	84.5	132	208	266	305	357	441	498	532	587	688	890	967	1036	1052	
KBL 770 P	770	75.4	92.9	145	229	293	335	393	485	547	585	647	755	979	1063	1139	1155	
KBL 800 P	800	78.2	96.5	151	237	304	348	408	503	567	608	671	784	1017	1105	1183	1199	
KBL 830 P	830	81.2	100	157	246	315	361	423	522	589	631	696	814	1055	1146	1228	1244	
KBL 860 P	860	84.2	104	162	255	327	374	439	542	611	653	722	845	1094	1189	1273	1290	
KBL 920 P	920	90.0	111	174	273	350	400	469	579	652	699	771	902	1170	1271	1361	1379	
KBL 970 P	970	94.8	117	183	288	369	422	495	611	690	737	813	953	1234	1340	1436	1458	
KBL 1020 P	1020	100	123	193	303	388	444	520	642	725	775	857	1000	1297	1407	1509	1529	
KBL 1040 P	1040	102	125	196	309	395	452	531	654	738	790	872	1020	1322	1436	1538	1559	
KBL 1070 P	1070	105	129	202	318	407	465	545	674	760	813	899	1049	1360	1476	1583	1604	
KBL 1140 P	1140	111	138	215	338	433	496	582	717	809	866	956	1118	1449	1575	1686	1709	
KBL 1220 P	1220	119	147	230	362	464	530	622	767	865	927	1023	1196	1551	1685	1805	1829	
KBL 1240 P	1240	121	150	234	368	471	539	633	780	879	942	1039	1216	1577	1713	1834	1859	
KBL 1280 P	1280	125	154	242	380	486	557	652	806	909	973	1075	1255	1627	1766	1893	1919	
KBL 1320 P	1320	129	159	249	392	502	575	673	832	939	1003	1106	1297	1679	1824	1954	1984	
KBL 1360 P	1360	133	164	257	404	517	591	694	855	965	1033	1140	1333	1729	1889	2012	2039	
KBL 1400 P	1400	137	169	264	416	532	609	714	882	994	1064	1176	1373	1780	1932	2071	2099	
KBL 1480 P	1480	145	179	279	440	562	644	755	932	1052	1125	1240	1454	1882	2045	2190	2224	
KBL 1540 P	1540	151	186	291	457	585	670	785	970	1094	1170	1293	1510	1958	2125	2278	2309	

Cell Performance **L** range
 Performance fully charged with constant current charging

Final Voltage: 1.10 V/cell

Available amperes at +20° C ± 5° C

Cell Type	C _s Ah	Hours								Minutes					Seconds			
		10	8	5	3	2	1.5	1	30	20	15	10	5	60	30	5	1	
KBL 8 P	8	0.80	0.99	1.55	2.46	3.40	4.06	4.79	5.97	6.81	7.28	8.00	9.42	12.0	13.0	14.5	15.7	
KBL 17 P	17	1.70	2.10	3.30	5.22	7.25	8.65	10.2	12.7	14.5	15.5	17.0	20.0	25.5	27.7	30.8	33.4	
KBL 21 P	21	2.10	2.60	4.07	6.45	8.96	10.7	12.6	15.7	17.9	19.1	21.0	24.7	31.5	34.2	38.0	41.3	
KBL 32 P	32	3.20	3.96	6.21	9.85	13.6	16.3	19.3	23.9	27.2	29.1	32.0	37.7	48.1	52.1	58.0	62.9	
KBL 38 P	38	3.80	4.70	7.38	11.7	16.2	19.3	22.9	28.4	32.3	34.6	38.0	44.8	57.1	61.9	68.8	74.7	
KBL 46 P	46	4.60	5.69	8.93	14.2	19.6	23.4	27.7	34.3	39.1	41.9	46.0	54.2	69.2	74.9	83.3	90.4	
KBL 50 P	50	5.03	6.20	9.70	15.4	21.2	25.1	29.5	37.0	41.6	44.5	49.1	58.1	74.1	79.5	86.1	87.0	
KBL 64 P	64	6.40	7.91	12.4	19.7	27.2	32.1	37.8	47.4	53.3	56.9	62.9	74.3	94.7	102	110	111	
KBL 73 P	73	7.33	9.02	14.2	22.5	31.0	36.6	43.1	54.0	60.8	64.9	71.8	84.8	108	116	126	127	
KBL 80 P	80	8.00	9.90	15.5	24.6	33.9	40.2	47.2	59.2	66.6	71.2	78.6	92.9	118	127	138	139	
KBL 90 P	90	9.05	11.2	17.5	27.7	38.2	45.2	53.1	66.6	74.9	80.1	88.2	105	133	143	155	157	
KBL 102 P	102	10.2	12.6	19.8	31.3	43.5	51.9	61.2	76.3	86.9	93.0	102	120	153	166	185	200	
KBL 118 P	118	11.8	14.6	22.9	36.3	50.1	59.2	69.6	87.3	98.3	105	116	137	175	188	203	205	
KBL 128 P	128	12.8	15.8	24.8	39.3	54.6	65.1	76.8	95.7	109	117	128	151	192	208	232	251	
KBL 140 P	140	14.1	17.3	27.2	43.1	59.4	70.3	82.6	104	117	125	137	162	207	223	241	243	
KBL 155 P	155	15.5	19.2	30.1	47.7	65.8	77.8	91.4	115	129	138	152	180	229	246	267	270	
KBL 173 P	173	17.4	21.4	33.5	53.3	73.4	86.8	102	128	144	154	170	201	256	275	298	301	
KBL 200 P	200	20.0	24.8	38.8	61.6	84.9	100	118	148	167	178	196	232	296	318	344	348	
KBL 214 P	214	21.5	26.5	41.5	65.9	90.8	107	126	158	178	190	210	248	317	340	368	372	
KBL 220 P	220	22.0	27.2	41.8	67.7	93.3	110	130	163	183	196	216	255	326	350	379	383	
KBL 256 P	256	25.7	31.7	49.6	78.8	109	129	151	189	213	228	251	297	379	407	441	445	
KBL 280 P	280	28.0	34.7	54.4	86.2	119	141	165	207	233	249	275	325	414	445	482	487	
KBL 304 P	304	30.6	37.7	58.9	93.6	129	153	179	225	253	270	298	353	450	483	523	529	
KBL 320 P	320	32.0	39.6	62.1	98.5	136	161	189	237	266	285	314	371	473	509	551	557	
KBL 346 P	346	34.8	42.9	67.1	107	147	174	204	256	288	308	339	401	512	550	596	602	
KBL 360 P	360	36.0	44.6	69.9	111	153	181	212	266	300	320	353	418	533	572	620	626	
KBL 390 P	390	39.3	48.3	75.6	120	165	196	230	289	325	347	382	452	577	620	671	678	
KBL 400 P	400	40.0	49.5	77.7	123	170	201	236	296	333	356	392	464	592	636	688	696	
KBL 429 P	429	43.1	53.2	83.2	132	182	215	253	318	356	382	421	498	635	682	738	746	
KBL 450 P	450	45.0	55.7	87.4	139	191	226	265	333	375	400	441	522	666	715	775	783	
KBL 465 P	465	46.8	57.5	90.1	143	197	233	274	344	387	414	456	539	688	739	800	809	
KBL 490 P	490	49.0	60.6	95.1	151	208	246	289	363	408	436	480	568	725	779	843	852	
KBL 510 P	510	51.3	63.2	98.9	157	216	256	301	377	423	454	500	592	755	810	878	887	
KBL 535 P	535	53.5	66.2	104	165	227	269	316	396	445	476	525	621	791	851	921	930	
KBL 570 P	570	57.0	70.5	111	175	242	286	336	422	475	507	559	661	843	906	981	991	
KBL 585 P	585	58.9	72.4	113	180	248	294	345	433	485	520	574	679	865	929	1006	1018	
KBL 620 P	620	62.0	76.7	120	191	263	311	366	459	516	552	608	719	917	986	1067	1078	
KBL 645 P	645	64.9	79.9	125	199	274	324	381	477	535	574	632	748	955	1025	1110	1122	
KBL 675 P	675	67.5	83.5	131	208	286	339	398	500	562	601	662	783	999	1073	1162	1174	
KBL 700 P	700	70.0	86.6	133	214	297	351	413	518	583	623	688	812	1036	1113	1205	1218	
KBL 770 P	770	77.5	95.4	149	237	327	387	454	570	638	685	755	893	1140	1224	1325	1340	
KBL 800 P	800	80.0	99.0	155	246	339	402	472	592	666	712	784	928	1183	1272	1377	1391	
KBL 830 P	830	83.0	103	161	255	352	417	490	614	691	738	814	963	1228	1320	1429	1443	
KBL 860 P	860	86.6	106	167	265	365	432	507	637	716	765	845	998	1273	1367	1481	1496	
KBL 920 P	920	92.0	114	179	283	390	462	543	681	766	819	902	1067	1361	1463	1583	1600	
KBL 970 P	970	97.0	120	184	299	412	487	572	718	808	863	953	1125	1435	1542	1670	1688	
KBL 1020 P	1020	103	126	198	314	433	512	602	755	846	908	1000	1183	1510	1621	1754	1775	
KBL 1040 P	1040	104	129	202	320	441	522	614	770	866	925	1020	1206	1538	1653	1790	1809	
KBL 1070 P	1070	108	133	207	329	454	537	631	792	887	952	1049	1241	1584	1700	1840	1862	
KBL 1140 P	1140	114	141	221	351	484	572	673	844	949	1014	1118	1323	1686	1812	1962	1983	
KBL 1220 P	1220	122	151	237	376	518	612	720	903	1016	1085	1196	1415	1805	1940	2100	2122	
KBL 1240 P	1240	124	153	241	382	526	622	732	918	1032	1103	1216	1439	1834	1971	2134	2157	
KBL 1280 P	1280	129	159	248	394	543	643	755	947	1061	1139	1255	1485	1895	2034	2201	2227	
KBL 1320 P	1320	132	163	251	406	560	662	778	977	1099	1175	1297	1531	1953	2098	2273	2297	
KBL 1360 P	1360	136	168	264	419	577	683	802	1007	1132	1210	1333	1578	2012	2162	2341	2365	
KBL 1400 P	1400	140	173	271	431	594	703	826	1036	1161	1246	1373	1624	2073	2224	2407	2436	
KBL 1480 P	1480	148	183	285	456	628	743	873	1095	1232	1317	1454	1717	2190	2353	2549	2575	

Cell Performance **L** range

Performance fully charged with constant current charging

Final Voltage: 1.05 V/cell

Available amperes at +20° C ± 5° C

Cell Type	C _s Ah	Hours								Minutes					Seconds			
		10	8	5	3	2	1.5	1	30	20	15	10	5	60	30	5	1	
KBL 8 P	8	0.82	1.01	1.58	2.54	3.60	4.47	5.37	7.05	7.94	8.51	9.47	11.1	14.2	15.4	16.8	18.5	
KBL 17 P	17	1.73	2.14	3.37	5.40	7.67	9.52	11.7	15.0	16.9	18.4	20.3	23.4	30.1	32.6	35.7	39.3	
KBL 21 P	21	2.13	2.65	4.16	6.67	9.48	11.8	14.5	18.5	20.8	22.7	25.0	28.9	37.2	40.3	44.1	48.5	
KBL 32 P	32	3.26	4.03	6.34	10.2	14.4	17.9	21.5	28.2	31.7	34.0	37.9	44.1	56.6	61.4	67.2	73.9	
KBL 38 P	38	3.86	4.79	7.52	12.1	17.1	21.2	25.5	33.5	37.7	40.4	45.0	52.3	67.3	72.9	79.8	88	
KBL 46 P	46	4.67	5.80	9.11	14.6	20.7	25.7	30.9	40.6	45.6	48.9	54.4	63.4	81.4	88.3	96.6	106	
KBL 50 P	50	5.11	6.30	9.90	15.9	22.5	27.9	34.1	43.1	48.5	52.5	58.5	67.7	86.1	93.1	104	110	
KBL 64 P	64	6.53	8.06	12.7	20.3	28.8	35.8	43.7	55.1	62.1	67.2	74.7	86.6	110	119	133	141	
KBL 73 P	73	7.47	9.19	14.5	23.2	33.0	40.8	50.0	62.9	70.8	76.7	85.5	98.8	126	136	152	161	
KBL 80 P	80	8.16	10.1	15.8	25.4	36.0	44.6	54.6	68.9	77.7	84.0	93.3	108	138	149	166	177	
KBL 90 P	90	9.21	11.3	17.8	28.6	40.5	50.2	61.4	77.5	87.3	94.5	105	122	155	168	187	199	
KBL 102 P	102	10.4	12.9	20.2	32.5	46.0	57.2	70.4	89.9	101	110	122	141	181	196	214	236	
KBL 118 P	118	12.0	14.9	23.4	37.5	53.1	65.8	80.5	102	115	124	138	160	203	219	245	260	
KBL 128 P	128	13.1	16.1	25.3	40.8	57.8	71.7	88.3	113	127	139	153	177	227	246	269	296	
KBL 140 P	140	14.3	17.6	27.7	44.4	63.0	78.1	95.5	121	136	147	163	189	241	260	291	309	
KBL 155 P	155	15.8	19.5	30.7	49.2	69.8	86.5	106	134	150	163	181	210	267	288	322	342	
KBL 173 P	173	17.7	21.8	34.3	54.9	77.9	96.5	118	149	168	182	203	234	297	322	360	382	
KBL 200 P	200	20.4	25.2	39.6	63.5	90.0	112	136	172	194	210	233	271	344	372	416	442	
KBL 214 P	214	21.9	27.0	42.4	68.0	96.3	119	146	184	208	225	251	289	368	398	445	473	
KBL 220 P	220	22.4	27.7	43.6	69.8	99.1	123	150	189	214	231	257	298	379	409	458	486	
KBL 256 P	256	26.2	32.2	50.7	81.3	115	143	175	220	248	269	300	346	440	476	532	565	
KBL 280 P	280	28.6	35.3	55.4	88.9	126	156	191	241	272	294	327	379	482	521	582	618	
KBL 304 P	304	31.1	38.3	60.2	96.6	137	170	207	262	295	319	356	411	523	565	632	671	
KBL 320 P	320	32.7	40.3	63.4	102	144	179	218	276	311	336	373	433	551	595	665	706	
KBL 346 P	346	35.4	43.6	68.5	110	156	193	236	298	336	363	405	468	595	643	719	764	
KBL 360 P	360	36.7	45.3	71.3	114	162	201	246	310	350	378	420	487	620	669	748	795	
KBL 390 P	390	39.9	49.1	77.2	124	176	218	266	336	378	409	457	527	671	725	811	861	
KBL 400 P	400	40.8	50.4	79.2	127	180	223	273	345	388	420	467	541	688	744	832	883	
KBL 429 P	429	43.9	54.0	85.0	136	193	239	293	370	416	450	502	580	738	798	892	947	
KBL 450 P	450	45.9	56.7	89.1	143	203	251	307	388	437	473	525	609	775	837	936	993	
KBL 465 P	465	47.5	58.5	92.1	148	209	259	317	401	451	488	544	628	800	865	967	1026	
KBL 490 P	490	50.0	61.7	97.0	156	221	273	334	422	476	515	572	663	843	911	1019	1082	
KBL 510 P	510	52.1	64.2	101	162	230	285	348	439	495	535	597	689	877	948	1060	1126	
KBL 535 P	535	54.6	67.4	106	170	241	299	365	461	519	562	624	724	921	995	1112	1181	
KBL 570 P	570	58.2	71.8	113	181	257	318	389	491	553	599	665	771	981	1060	1185	1258	
KBL 585 P	585	59.8	73.7	116	186	263	326	399	504	568	614	685	791	1006	1088	1216	1291	
KBL 620 P	620	63.3	78.1	123	197	279	346	423	534	602	651	723	839	1067	1153	1289	1369	
KBL 645 P	645	65.9	81.2	128	205	290	360	440	556	626	677	755	872	1109	1199	1341	1424	
KBL 675 P	675	68.9	85.0	134	214	304	377	460	581	655	709	788	913	1162	1255	1403	1490	
KBL 700 P	700	71.4	88.1	139	222	315	391	477	603	680	735	817	947	1206	1302	1455	1545	
KBL 770 P	770	78.7	97.0	152	245	347	430	525	663	747	808	902	1041	1324	1432	1601	1700	
KBL 800 P	800	81.6	101	158	254	360	446	546	689	777	840	933	1083	1377	1488	1663	1766	
KBL 830 P	830	84.7	104	164	263	374	463	566	715	806	872	968	1123	1429	1543	1726	1832	
KBL 860 P	860	87.9	108	170	273	387	480	587	741	835	903	1007	1164	1479	1599	1788	1898	
KBL 920 P	920	93.9	116	182	292	414	513	628	792	893	966	1074	1245	1583	1711	1913	2031	
KBL 970 P	970	99.0	122	192	308	437	541	662	835	942	1019	1132	1313	1671	1804	2017	2141	
KBL 1020 P	1020	104	128	202	324	459	569	696	879	990	1070	1194	1378	1754	1897	2121	2252	
KBL 1040 P	1040	106	131	206	330	468	580	709	896	1010	1092	1214	1407	1790	1934	2162	2296	
KBL 1070 P	1070	109	135	212	340	482	597	730	922	1038	1123	1253	1446	1840	1990	2225	2362	
KBL 1140 P	1140	116	144	226	362	513	636	778	982	1107	1197	1330	1543	1962	2120	2370	2517	
KBL 1220 P	1220	124	154	242	387	549	681	832	1051	1184	1282	1424	1651	2100	2269	2536	2693	
KBL 1240 P	1240	127	156	246	394	558	692	846	1068	1204	1303	1447	1678	2134	2306	2578	2737	
KBL 1280 P	1280	131	161	253	407	576	714	873	1102	1242	1343	1498	1730	2201	2380	2661	2826	
KBL 1320 P	1320	135	166	261	419	594	737	900	1137	1282	1386	1540	1786	2274	2454	2744	2914	
KBL 1360 P	1360	139	171	269	432	612	759	928	1171	1320	1429	1587	1840	2341	2529	2827	3002	
KBL 1400 P	1400	143	176	277	445	630	781	955	1206	1358	1469	1638	1892	2407	2603	2911	3091	
KBL 1480 P	1480	151	186	293	470	666	826	1009	1275	1437	1554	1727	2003	2549	2752	3077	3267	

Cell Performance **L** range
 Performance fully charged with constant current charging

Available amperes at +20° C ± 5° C

Final Voltage: 1.00 V/cell

Cell Type	C _s Ah	Hours								Minutes					Seconds			
		10	8	5	3	2	1.5	1	30	20	15	10	5	60	30	5	1	
KBL 8 P	8	0.83	1.01	1.60	2.59	3.72	4.70	6.16	7.94	9.06	9.78	10.9	12.7	16.7	17.8	19.6	21.2	
KBL 17 P	17	1.74	2.15	3.40	5.51	7.90	9.99	13.1	16.9	19.3	20.8	23.2	26.7	34.4	37.3	41.7	45.1	
KBL 21 P	21	2.15	2.66	4.20	6.80	9.76	12.4	16.2	20.8	23.8	25.7	28.6	33.0	42.5	46.1	51.5	55.7	
KBL 32 P	32	3.27	4.05	6.40	10.4	14.9	18.8	24.6	31.7	36.2	39.1	43.6	50.2	64.8	70.2	78.4	84.9	
KBL 38 P	38	3.89	4.81	7.60	12.3	17.7	22.3	29.3	37.7	43.0	46.5	51.8	59.7	76.9	83.3	93	101	
KBL 46 P	46	4.71	5.83	9.20	14.9	21.4	27.0	35.4	45.6	52.1	56.2	62.7	72.2	93.1	101	113	122	
KBL 50 P	50	5.16	6.35	10.0	16.2	23.2	29.2	37.6	48.5	55.5	60.1	66.5	76.6	98.6	106	120	124	
KBL 64 P	64	6.56	8.10	12.8	20.7	29.7	37.4	48.1	62.1	71.0	76.8	85.1	98.0	126	136	153	159	
KBL 73 P	73	7.54	9.28	14.6	23.6	33.9	42.7	54.9	70.9	81.0	87.6	97.1	112	144	155	175	181	
KBL 80 P	80	8.26	10.1	16.0	25.9	37.1	46.7	60.1	77.7	88.8	96.0	106	123	158	170	192	199	
KBL 90 P	90	9.29	11.4	18.0	29.1	41.8	52.7	67.6	87.4	99.9	108	120	138	177	192	216	223	
KBL 102 P	102	10.5	13.0	20.4	33.0	47.4	60.0	78.5	101	116	125	139	160	206	224	250	270	
KBL 118 P	118	12.2	14.9	23.6	38.2	54.8	69.1	88.7	115	131	142	157	181	233	251	283	293	
KBL 128 P	128	13.2	16.3	25.6	41.5	59.5	75.2	98.5	127	145	156	174	201	259	281	314	339	
KBL 140 P	140	14.5	17.7	28.0	45.3	65.0	82.0	105	136	155	168	186	214	276	298	337	347	
KBL 155 P	155	16.0	19.6	31.0	50.2	71.9	90.8	116	150	172	186	206	237	306	330	372	385	
KBL 173 P	173	17.9	22.0	34.6	56.0	80.3	101	130	168	192	208	230	265	341	369	416	429	
KBL 200 P	200	20.7	25.4	40.0	64.7	92.8	117	150	194	222	240	266	306	394	426	480	496	
KBL 214 P	214	22.1	27.2	42.8	69.3	99.3	125	161	208	238	257	285	327	422	456	514	531	
KBL 220 P	220	22.5	28.0	44.0	71.2	102	129	165	214	244	264	293	337	434	468	528	546	
KBL 256 P	256	26.4	32.5	51.2	82.8	119	150	192	249	284	307	340	392	504	546	615	635	
KBL 280 P	280	28.9	35.6	56.0	90.6	130	164	210	272	311	336	372	429	552	596	671	695	
KBL 304 P	304	31.4	38.7	60.8	98.4	141	178	228	295	337	365	404	465	599	648	730	755	
KBL 320 P	320	33.0	40.7	64.0	104	148	187	240	311	355	384	426	490	631	681	767	794	
KBL 346 P	346	35.7	44.0	69.2	112	161	203	260	336	384	415	460	529	682	737	831	859	
KBL 360 P	360	37.2	45.8	72.0	117	167	211	270	350	400	432	479	551	710	766	863	893	
KBL 390 P	390	40.3	49.6	78.0	126	181	228	293	379	433	468	519	597	768	831	937	968	
KBL 400 P	400	41.3	50.9	80.0	129	186	234	301	388	444	480	532	613	789	851	959	993	
KBL 429 P	429	44.3	54.5	85.8	139	199	251	322	417	476	515	570	656	845	914	1030	1065	
KBL 450 P	450	46.5	57.2	90.0	146	209	264	338	437	499	540	598	689	888	957	1079	1117	
KBL 465 P	465	48.0	59.1	93.0	150	216	272	349	451	516	558	618	711	916	991	1117	1154	
KBL 490 P	490	50.6	62.3	98.0	159	227	287	368	476	544	588	652	750	966	1043	1175	1216	
KBL 510 P	510	52.7	64.8	102	165	237	299	383	495	566	612	678	780	1005	1087	1225	1266	
KBL 535 P	535	55.2	68.0	107	173	248	313	402	519	594	642	711	819	1055	1138	1283	1328	
KBL 570 P	570	58.9	72.5	114	184	265	334	428	553	633	684	758	873	1124	1213	1367	1414	
KBL 585 P	585	60.4	74.4	117	189	271	343	440	568	649	702	778	895	1153	1247	1405	1452	
KBL 620 P	620	64.0	78.8	124	201	288	363	466	602	688	744	824	949	1223	1319	1487	1538	
KBL 645 P	645	66.6	82.0	129	209	299	378	485	626	716	774	858	987	1271	1375	1549	1601	
KBL 675 P	675	69.7	85.8	135	218	313	395	507	655	749	810	898	1034	1331	1436	1619	1675	
KBL 700 P	700	71.6	89.0	140	227	325	409	526	680	777	840	931	1072	1380	1489	1680	1736	
KBL 770 P	770	79.5	97.9	154	249	357	451	578	748	855	924	1024	1178	1517	1641	1849	1911	
KBL 800 P	800	82.6	102	160	259	371	469	601	777	888	960	1064	1225	1578	1702	1918	1985	
KBL 830 P	830	85.7	106	166	269	385	486	624	806	921	996	1104	1271	1637	1766	1990	2060	
KBL 860 P	860	88.8	109	172	278	399	502	646	835	954	1032	1144	1317	1695	1833	2065	2135	
KBL 920 P	920	95.0	117	184	298	427	539	691	893	1021	1104	1223	1409	1815	1957	2206	2283	
KBL 970 P	970	100	123	194	314	450	567	729	942	1077	1164	1290	1486	1912	2063	2328	2406	
KBL 1020 P	1020	105	130	204	330	473	598	766	990	1132	1224	1356	1561	2010	2174	2450	2532	
KBL 1040 P	1040	107	132	208	337	483	609	781	1010	1154	1248	1383	1593	2051	2213	2494	2581	
KBL 1070 P	1070	110	136	214	346	497	627	803	1039	1188	1285	1423	1637	2108	2280	2570	2656	
KBL 1140 P	1140	118	145	228	369	529	668	856	1107	1265	1369	1516	1746	2249	2426	2734	2829	
KBL 1220 P	1220	126	155	244	395	566	715	917	1184	1354	1465	1622	1868	2406	2596	2926	3027	
KBL 1240 P	1240	128	158	248	401	575	726	932	1204	1376	1489	1649	1899	2446	2638	2974	3077	
KBL 1280 P	1280	132	163	256	414	594	750	961	1243	1421	1537	1702	1958	2522	2728	3074	3177	
KBL 1320 P	1320	136	168	264	427	613	771	992	1282	1465	1585	1755	2022	2604	2808	3168	3274	
KBL 1360 P	1360	140	173	272	440	631	797	1022	1320	1509	1633	1809	2083	2682	2894	3261	3375	
KBL 1400 P	1400	145	178	280	453	650	820	1051	1359	1554	1681	1862	2142	2759	2984	3362	3475	
KBL 1480 P	1480	153	188	296	479	687	864	1112	1437	1643	1777	1968	2267	2917	3148	3552	3671	

Cell Performance **L** range

Performance after long term floating with constant voltage charging

Final Voltage: 1.14V/cell

Available amperes at +20° C ± 5° C

Cell Type	C _s Ah	Hours								Minutes					Seconds			
		10	8	5	3	2	1.5	1	30	20	15	10	5	60	30	5	1	
KBL 8 P	8	0.79	0.97	1.51	2.27	2.66	2.90	3.11	3.56	3.83	4.12	4.59	5.32	6.93	7.43	7.90	8.86	
KBL 17 P	17	1.66	2.06	3.21	4.82	5.71	6.21	6.64	7.55	8.13	8.76	9.67	11.1	14.5	15.5	16.8	18.8	
KBL 21 P	21	2.05	2.54	3.96	5.95	7.05	7.67	8.20	9.33	10.0	10.8	11.9	13.7	17.9	19.2	20.7	23.2	
KBL 32 P	32	3.13	3.87	6.04	9.08	10.6	11.6	12.4	14.2	15.2	16.5	18.1	20.7	27.4	29.3	31.6	35.4	
KBL 38 P	38	3.72	4.59	7.17	10.8	12.6	13.8	14.8	16.9	18.1	19.6	21.4	24.5	32.5	34.7	37.5	42.1	
KBL 46 P	46	4.50	5.56	8.68	13.0	15.3	16.7	17.9	20.4	21.9	23.7	25.9	29.7	39.3	42.1	45.4	50.9	
KBL 50 P	50	4.89	6.03	9.43	14.2	16.6	18.0	19.5	21.9	23.6	25.3	27.7	32.0	41.3	44.9	48.1	48.7	
KBL 64 P	64	6.26	7.72	12.1	18.1	21.3	23.1	24.9	28.0	30.2	32.2	35.4	40.9	52.9	57.5	61.5	62.4	
KBL 73 P	73	7.14	8.81	13.8	20.7	24.3	26.3	28.5	31.9	34.6	36.9	40.5	46.8	60.4	65.5	70.2	71.4	
KBL 80 P	80	7.82	9.65	15.1	22.7	26.6	28.9	31.2	35.0	37.7	40.4	44.3	51.1	66.1	71.8	76.9	78.0	
KBL 90 P	90	8.81	10.9	17.0	25.5	29.9	32.5	35.1	39.4	42.5	45.5	49.9	57.5	74.4	80.8	86.5	87.7	
KBL 102 P	102	9.99	12.3	19.3	28.9	34.3	37.3	39.8	45.4	48.8	51.5	57.9	66.5	87.2	93.4	101	113	
KBL 118 P	118	11.5	14.2	22.3	33.4	39.2	42.6	46.1	51.6	55.7	59.6	65.3	75.4	97.5	106	113	115	
KBL 128 P	128	12.5	15.5	24.2	36.3	43.0	46.8	50.0	56.9	61.2	64.7	72.6	83.5	109	117	126	142	
KBL 140 P	140	13.7	16.9	26.4	39.7	46.5	50.5	54.6	61.3	66.2	70.7	77.5	89.5	116	126	135	136	
KBL 155 P	155	15.2	18.7	29.2	43.9	51.5	55.9	60.5	67.8	73.1	78.3	85.8	99.1	128	139	149	151	
KBL 173 P	173	16.9	20.9	32.7	49.1	57.5	62.4	67.5	75.6	81.6	87.4	95.7	111	143	155	166	169	
KBL 200 P	200	19.6	24.1	37.7	56.7	66.5	72.2	78.1	87.4	94.3	101	111	128	165	180	192	195	
KBL 214 P	214	20.9	25.8	40.4	60.7	71.1	77.3	83.5	93.5	101	108	119	137	177	192	206	209	
KBL 220 P	220	21.5	26.6	41.5	62.3	73.1	79.5	85.9	96.5	104	111	122	141	182	198	212	215	
KBL 256 P	256	25.1	30.9	48.3	72.5	85.1	92.4	99.8	112	121	129	142	164	212	230	246	249	
KBL 280 P	280	27.4	33.8	52.8	79.3	93.1	101	109	122	132	141	155	179	231	251	269	273	
KBL 304 P	304	29.8	36.7	57.4	86.2	101	110	119	133	143	154	168	194	251	273	292	296	
KBL 320 P	320	31.3	38.6	60.4	90.7	106	115	125	140	151	162	177	205	264	287	308	312	
KBL 346 P	346	33.9	41.7	65.3	98.1	115	125	135	151	164	175	192	221	286	310	333	337	
KBL 360 P	360	35.2	43.4	67.9	102	120	130	141	157	170	182	199	230	298	323	346	351	
KBL 390 P	390	38.2	47.0	73.6	111	130	141	152	171	185	197	216	249	322	350	375	380	
KBL 400 P	400	39.1	48.3	75.5	113	133	144	156	175	189	202	221	256	331	359	385	390	
KBL 429 P	429	42.0	51.7	81.0	122	143	155	167	188	203	217	237	274	355	385	413	418	
KBL 450 P	450	44.0	54.3	84.9	128	150	162	176	197	212	227	249	288	372	404	433	439	
KBL 465 P	465	45.5	56.1	87.7	132	155	168	181	203	220	235	258	297	384	417	447	453	
KBL 490 P	490	47.9	59.1	92.5	139	163	177	191	214	231	248	271	313	405	440	471	478	
KBL 510 P	510	49.9	61.5	96.3	145	170	184	199	223	241	258	283	326	421	458	490	497	
KBL 535 P	535	52.3	64.5	101	152	178	193	209	234	252	270	296	342	442	480	514	521	
KBL 570 P	570	55.7	68.8	108	162	189	206	222	249	269	288	315	364	471	512	548	555	
KBL 585 P	585	57.2	70.6	110	166	194	211	228	256	276	296	324	374	483	525	563	570	
KBL 620 P	620	60.6	74.8	117	176	206	224	242	271	292	313	343	396	512	557	596	604	
KBL 645 P	645	63.1	77.8	122	183	214	233	252	282	305	326	357	412	533	579	620	629	
KBL 675 P	675	66.0	81.4	127	191	224	244	263	295	318	341	373	431	558	606	649	658	
KBL 700 P	700	68.4	84.5	132	198	233	253	273	306	331	354	387	448	579	628	673	684	
KBL 770 P	770	75.4	92.9	145	218	256	278	301	337	364	389	427	492	636	691	740	751	
KBL 800 P	800	78.2	96.5	151	227	266	289	312	350	377	404	443	511	661	718	769	780	
KBL 830 P	830	81.2	100	157	235	276	300	324	363	391	419	459	531	686	745	798	809	
KBL 860 P	860	84.2	104	162	244	286	310	336	376	406	435	476	551	711	773	827	838	
KBL 920 P	920	90.0	111	174	261	306	332	359	402	434	465	509	588	760	826	885	897	
KBL 970 P	970	94.8	117	183	275	322	350	379	425	459	490	537	621	802	871	933	948	
KBL 1020 P	1020	99.8	123	193	289	339	368	398	446	482	515	566	652	843	915	981	994	
KBL 1040 P	1040	102	125	196	295	346	375	406	455	490	526	575	665	860	934	1000	1013	
KBL 1070 P	1070	105	129	202	303	356	386	417	468	505	541	593	684	884	960	1029	1043	
KBL 1140 P	1140	111	138	215	323	379	411	445	498	538	576	631	729	942	1023	1096	1111	
KBL 1220 P	1220	119	147	230	346	406	440	476	533	575	616	675	780	1008	1095	1173	1189	
KBL 1240 P	1240	121	150	234	351	412	447	484	542	585	627	686	793	1025	1113	1192	1208	
KBL 1280 P	1280	125	154	242	363	426	462	499	560	605	647	709	818	1058	1148	1231	1247	
KBL 1320 P	1320	129	159	249	374	439	477	515	578	624	667	730	845	1091	1185	1270	1289	
KBL 1360 P	1360	133	164	257	385	452	491	531	594	641	687	752	869	1124	1228	1308	1325	
KBL 1400 P	1400	137	169	264	397	465	505	546	613	661	707	776	895	1157	1256	1346	1364	
KBL 1480 P	1480	145	179	279	420	492	534	578	648	700	748	819	948	1223	1329	1424	1446	
KBL 1540 P	1540	151	186	291	436	512	556	600	674	727	778	853	984	1273	1381	1481	1501	

Cell Performance **L** range

Performance after long term floating with constant voltage charging

Final Voltage: 1.10 V/cell

Available amperes at +20° C ± 5° C

Cell Type	C _s Ah	Hours								Minutes					Seconds			
		10	8	5	3	2	1.5	1	30	20	15	10	5	60	30	5	1	
KBL 8 P	8	0.80	0.99	1.55	2.41	3.13	3.55	3.90	4.51	4.97	5.24	5.68	6.60	8.36	9.06	10.1	10.9	
KBL 17 P	17	1.70	2.10	3.30	5.10	6.67	7.57	8.31	9.60	10.6	11.1	12.1	14.0	17.7	19.2	21.4	23.2	
KBL 21 P	21	2.10	2.60	4.07	6.30	8.24	9.35	10.3	11.9	13.1	13.8	14.9	17.3	21.9	23.8	26.4	28.7	
KBL 32 P	32	3.20	3.96	6.21	9.62	12.5	14.2	15.7	18.0	19.9	21.0	22.7	26.4	33.4	36.2	40.3	43.7	
KBL 38 P	38	3.80	4.70	7.38	11.4	14.9	16.9	18.7	21.4	23.6	24.9	27.0	31.3	39.7	43.0	47.8	51.9	
KBL 46 P	46	4.60	5.69	8.93	13.8	18.0	20.5	22.6	25.9	28.6	30.1	32.7	37.9	48.1	52.1	57.9	62.8	
KBL 50 P	50	5.03	6.20	9.70	15.0	19.5	22.0	24.0	27.9	30.4	32.0	34.9	40.7	51.5	55.2	59.8	60.5	
KBL 64 P	64	6.40	7.91	12.4	19.2	25.0	28.1	30.8	35.8	38.9	41.0	44.6	52.0	65.8	70.7	76.6	77.4	
KBL 73 P	73	7.33	9.02	14.2	22.0	28.5	32.1	35.1	40.8	44.4	46.8	51.0	59.3	75.1	80.8	87.3	88.3	
KBL 80 P	80	8.00	9.90	15.5	24.1	31.2	35.1	38.5	44.7	48.6	51.2	55.8	65.0	82.2	88.4	95.7	96.7	
KBL 90 P	90	9.05	11.2	17.5	27.1	35.1	39.5	43.3	50.3	54.7	57.7	62.6	73.2	92.5	99.4	108	109	
KBL 102 P	102	10.2	12.6	19.8	30.6	40.0	45.4	49.9	57.6	63.4	66.9	72.4	84.1	107	115	128	139	
KBL 118 P	118	11.8	14.6	22.9	35.5	46.1	51.8	56.7	65.9	71.7	75.6	82.1	95.8	121	130	141	143	
KBL 128 P	128	12.8	15.8	24.8	38.4	50.2	57.0	62.6	72.3	79.6	84.0	90.9	106	134	145	161	175	
KBL 140 P	140	14.1	17.3	27.2	42.1	54.6	61.5	67.3	78.2	85.1	89.7	97.5	114	144	155	167	169	
KBL 155 P	155	15.5	19.2	30.1	46.6	60.5	68.1	74.5	86.6	94.2	99.3	108	126	159	171	185	187	
KBL 173 P	173	17.4	21.4	33.5	52.1	67.5	76.0	83.2	96.7	105	111	120	140	178	191	207	209	
KBL 200 P	200	20.0	24.8	38.8	60.1	78.1	87.9	96.2	112	122	128	139	162	206	221	239	242	
KBL 214 P	214	21.5	26.5	41.5	64.4	83.5	94.0	103	120	130	137	149	174	220	236	256	259	
KBL 220 P	220	22.0	27.2	41.8	66.2	85.9	96.6	106	123	134	141	153	179	227	243	263	266	
KBL 256 P	256	25.7	31.7	49.6	77.0	99.9	112	123	143	156	164	178	208	263	283	306	309	
KBL 280 P	280	28.0	34.7	54.4	84.2	109	123	135	156	170	179	195	227	288	309	335	338	
KBL 304 P	304	30.6	37.7	58.9	91.4	119	134	146	170	185	195	212	247	313	336	364	367	
KBL 320 P	320	32.0	39.6	62.1	96.2	125	141	154	179	195	205	223	260	329	354	383	387	
KBL 346 P	346	34.8	42.9	67.1	104	135	152	166	193	210	222	241	281	356	382	414	418	
KBL 360 P	360	36.0	44.6	69.9	108	141	158	173	201	219	231	251	292	370	398	431	435	
KBL 390 P	390	39.3	48.3	75.6	117	152	171	188	218	237	250	271	317	401	431	467	471	
KBL 400 P	400	40.0	49.5	77.7	120	156	176	192	224	243	256	278	325	411	442	478	483	
KBL 429 P	429	43.1	53.2	83.2	129	167	188	206	240	260	275	299	348	441	474	513	519	
KBL 450 P	450	45.0	55.7	87.4	135	176	198	216	251	274	288	313	365	463	497	538	544	
KBL 465 P	465	46.8	57.5	90.1	140	182	204	224	260	283	298	324	378	478	514	556	562	
KBL 490 P	490	49.0	60.6	95.1	147	191	215	236	274	298	314	341	398	504	541	586	592	
KBL 510 P	510	51.3	63.2	98.9	153	199	224	245	285	309	327	355	414	525	563	610	616	
KBL 535 P	535	53.5	66.2	104	161	209	235	257	299	325	343	372	434	550	591	640	647	
KBL 570 P	570	57.0	70.5	111	171	222	250	274	319	346	365	397	463	586	630	682	689	
KBL 585 P	585	58.9	72.4	113	176	228	257	281	327	354	375	407	475	601	646	699	707	
KBL 620 P	620	62.0	76.7	120	186	242	272	298	346	377	397	432	503	637	685	742	749	
KBL 645 P	645	64.9	79.9	125	194	252	283	310	360	390	413	449	524	664	713	772	780	
KBL 675 P	675	67.5	83.5	131	203	263	296	325	377	410	432	470	548	694	746	807	816	
KBL 700 P	700	70.0	86.6	133	209	273	307	337	391	425	448	488	568	720	773	837	846	
KBL 770 P	770	77.5	95.4	149	232	301	338	370	430	466	493	536	625	792	851	921	931	
KBL 800 P	800	80.0	99.0	155	241	312	351	385	447	486	512	557	650	822	884	957	967	
KBL 830 P	830	83.0	103	161	250	324	365	399	464	504	532	578	674	853	917	993	1003	
KBL 860 P	860	86.6	106	167	259	336	378	414	481	523	551	600	698	885	950	1030	1039	
KBL 920 P	920	92.0	114	179	277	359	404	442	514	559	589	640	747	946	1017	1101	1112	
KBL 970 P	970	97.0	120	184	292	379	426	466	542	590	621	677	788	997	1072	1160	1173	
KBL 1020 P	1020	103	126	198	307	398	448	490	570	617	654	710	828	1049	1126	1219	1234	
KBL 1040 P	1040	104	129	202	313	406	457	500	581	632	666	724	845	1069	1149	1244	1257	
KBL 1070 P	1070	108	133	207	322	418	470	514	598	648	685	745	869	1101	1182	1279	1294	
KBL 1140 P	1140	114	141	221	343	445	501	548	637	693	730	794	926	1172	1260	1364	1378	
KBL 1220 P	1220	122	151	237	367	476	536	587	682	742	781	849	991	1254	1348	1459	1475	
KBL 1240 P	1240	124	153	241	373	484	545	596	693	754	794	863	1007	1275	1370	1483	1499	
KBL 1280 P	1280	129	159	248	385	500	562	615	715	775	820	891	1039	1317	1413	1530	1548	
KBL 1320 P	1320	132	163	251	397	515	580	634	738	802	846	921	1072	1357	1458	1580	1596	
KBL 1360 P	1360	136	168	264	409	531	597	654	760	827	871	947	1104	1398	1503	1627	1644	
KBL 1400 P	1400	140	173	271	421	546	615	673	782	847	897	975	1137	1440	1546	1673	1693	
KBL 1480 P	1480	148	183	285	445	578	650	712	827	900	948	1032	1202	1522	1635	1772	1789	
KBL 1540 P	1540	155	191	299	463	601	676	740	861	932	986	1072	1251	1584	1701	1839	1862	

Cell Performance **L** range

Performance after long term floating with constant voltage charging

Final Voltage: 1.05 V/cell

Available amperes at +20° C ± 5° C

Cell Type	C _s Ah	Hours								Minutes					Seconds			
		10	8	5	3	2	1.5	1	30	20	15	10	5	60	30	5	1	
KBL 8 P	8	0.82	1.01	1.58	2.54	3.42	4.09	4.62	5.64	6.19	6.51	7.15	8.28	10.4	11.3	12.4	13.6	
KBL 17 P	17	1.73	2.14	3.37	5.40	7.29	8.71	10.1	12.0	13.2	14.1	15.3	17.4	22.1	24.0	26.3	28.9	
KBL 21 P	21	2.13	2.65	4.16	6.67	9.01	10.8	12.5	14.8	16.3	17.4	18.9	21.5	27.3	29.6	32.4	35.6	
KBL 32 P	32	3.26	4.03	6.34	10.2	13.7	16.4	18.5	22.6	24.8	26.0	28.6	32.8	41.6	45.1	49.4	54.3	
KBL 38 P	38	3.86	4.79	7.52	12.1	16.2	19.4	21.9	26.8	29.4	30.9	34.0	39.0	49.4	53.6	58.7	64.5	
KBL 46 P	46	4.67	5.80	9.11	14.6	19.7	23.5	26.6	32.5	35.6	37.4	41.1	47.2	59.8	64.9	71.0	78.1	
KBL 50 P	50	5.11	6.30	9.90	15.9	21.4	25.5	29.3	34.5	37.9	40.2	44.2	50.4	63.3	68.4	76.4	81.1	
KBL 64 P	64	6.53	8.06	12.7	20.3	27.4	32.7	37.5	44.1	48.4	51.4	56.4	64.5	81.0	87.6	97.8	104	
KBL 73 P	73	7.47	9.19	14.5	23.2	31.3	37.3	43.0	50.3	55.2	58.7	64.5	73.6	92.3	99.9	112	118	
KBL 80 P	80	8.16	10.1	15.8	25.4	34.2	40.8	46.9	55.1	60.6	64.3	70.5	80.6	101	109	122	130	
KBL 90 P	90	9.21	11.3	17.8	28.6	38.5	46.0	52.8	62.0	68.1	72.3	79.3	90.7	114	123	138	146	
KBL 102 P	102	10.4	12.9	20.2	32.5	43.7	52.3	60.5	72.0	78.9	84.4	91.8	105	133	144	158	173	
KBL 118 P	118	12.0	14.9	23.4	37.5	50.5	60.3	69.2	81.3	89.4	94.8	104	119	149	161	180	191	
KBL 128 P	128	13.1	16.1	25.3	40.8	54.9	65.7	76.0	90.3	99.0	106	115	132	167	181	198	217	
KBL 140 P	140	14.3	17.6	27.7	44.4	59.9	71.5	82.1	96.5	106	112	123	141	177	191	214	227	
KBL 155 P	155	15.8	19.5	30.7	49.2	66.3	79.1	90.9	107	117	125	137	156	196	212	237	251	
KBL 173 P	173	17.7	21.8	34.3	54.9	74.0	88.3	101	119	131	139	153	174	219	236	264	281	
KBL 200 P	200	20.4	25.2	39.6	63.5	85.5	102	117	138	151	161	176	202	253	273	306	325	
KBL 214 P	214	21.9	27.0	42.4	68.0	91.5	109	126	147	162	172	189	215	271	292	327	348	
KBL 220 P	220	22.4	27.7	43.6	69.8	94.1	112	129	152	167	177	194	222	278	301	337	357	
KBL 256 P	256	26.2	32.2	50.7	81.3	109	131	150	176	194	206	226	258	324	350	391	415	
KBL 280 P	280	28.6	35.3	55.4	88.9	120	143	164	193	212	225	247	282	354	383	428	454	
KBL 304 P	304	31.1	38.3	60.2	96.6	130	155	178	209	230	244	269	306	385	415	465	493	
KBL 320 P	320	32.7	40.3	63.4	102	137	163	188	220	242	257	282	323	405	437	489	519	
KBL 346 P	346	35.4	43.6	68.5	110	148	177	203	238	262	278	306	348	437	473	529	561	
KBL 360 P	360	36.7	45.3	71.3	114	154	184	211	248	273	289	317	363	455	492	550	584	
KBL 390 P	390	39.9	49.1	77.2	124	167	199	229	269	295	313	345	393	493	533	596	633	
KBL 400 P	400	40.8	50.4	79.2	127	171	204	235	276	303	321	352	403	506	547	611	649	
KBL 429 P	429	43.9	54.0	85.0	136	183	219	252	296	325	344	379	432	543	586	656	696	
KBL 450 P	450	45.9	56.7	89.1	143	192	230	264	310	341	362	396	454	569	615	688	730	
KBL 465 P	465	47.5	58.5	92.1	148	199	237	273	320	352	373	411	468	588	636	711	754	
KBL 490 P	490	50.0	61.7	97.0	156	209	250	287	338	371	394	432	494	620	670	749	795	
KBL 510 P	510	52.1	64.2	101	162	218	260	299	351	386	409	451	513	645	697	779	827	
KBL 535 P	535	54.6	67.4	106	170	229	273	314	369	405	430	471	539	677	731	818	868	
KBL 570 P	570	58.2	71.8	113	181	244	291	334	393	432	458	502	575	721	779	871	925	
KBL 585 P	585	59.8	73.7	116	186	250	299	343	403	443	470	517	589	739	800	894	949	
KBL 620 P	620	63.3	78.1	123	197	265	317	364	427	470	498	546	625	784	847	947	1006	
KBL 645 P	645	65.9	81.2	128	205	276	329	378	444	488	518	570	649	815	882	986	1047	
KBL 675 P	675	68.9	85.0	134	214	289	345	396	465	511	542	595	680	854	923	1031	1095	
KBL 700 P	700	71.4	88.1	139	222	299	357	411	482	530	563	617	706	886	957	1070	1136	
KBL 770 P	770	78.7	97.0	152	245	329	393	452	531	583	618	681	775	973	1052	1177	1249	
KBL 800 P	800	81.6	101	158	254	342	408	469	551	606	643	705	806	1012	1093	1222	1298	
KBL 830 P	830	84.7	104	164	263	355	424	487	572	629	667	731	837	1050	1134	1268	1347	
KBL 860 P	860	87.9	108	170	273	368	439	505	593	651	691	760	867	1087	1175	1314	1395	
KBL 920 P	920	93.9	116	182	292	393	470	540	634	697	739	811	927	1164	1257	1406	1493	
KBL 970 P	970	99.0	122	192	308	415	495	569	668	735	779	855	978	1228	1326	1482	1574	
KBL 1020 P	1020	104	128	202	324	436	521	598	703	772	819	902	1027	1289	1394	1559	1655	
KBL 1040 P	1040	106	131	206	330	445	531	610	717	788	836	916	1048	1316	1421	1589	1687	
KBL 1070 P	1070	109	135	212	340	457	546	628	737	810	859	946	1077	1352	1462	1635	1736	
KBL 1140 P	1140	116	144	226	362	487	582	669	786	863	916	1004	1149	1442	1558	1742	1850	
KBL 1220 P	1220	124	154	242	387	522	623	716	841	924	980	1075	1230	1543	1667	1864	1979	
KBL 1240 P	1240	127	156	246	394	530	633	727	854	939	996	1092	1250	1569	1695	1895	2012	
KBL 1280 P	1280	131	161	253	407	547	654	751	882	969	1027	1131	1289	1618	1749	1956	2077	
KBL 1320 P	1320	135	166	261	419	564	674	774	910	1000	1060	1163	1331	1671	1804	2017	2142	
KBL 1360 P	1360	139	171	269	432	581	694	798	937	1030	1093	1198	1371	1720	1859	2078	2207	
KBL 1400 P	1400	143	176	277	445	599	715	821	965	1059	1123	1237	1409	1769	1913	2139	2272	
KBL 1480 P	1480	151	186	293	470	633	756	868	1020	1121	1189	1304	1492	1874	2023	2262	2401	
KBL 1540 P	1540	157	194	305	489	658	786	903	1061	1165	1236	1361	1550	1946	2105	2353	2499	

Cell Performance **L** range

Performance after long term floating with constant voltage charging

Final Voltage: 1.00 V/cell

Available amperes at +20° C ± 5° C

Cell Type	C _s Ah	Hours								Minutes					Seconds			
		10	8	5	3	2	1.5	1	30	20	15	10	5	60	30	5	1	
KBL 8 P	8	0.83	1.01	1.60	2.59	3.57	4.46	5.54	6.67	7.43	7.92	8.75	10.1	13.2	14.0	15.5	16.8	
KBL 17 P	17	1.74	2.15	3.40	5.51	7.59	9.47	11.8	14.2	15.8	16.8	18.6	21.3	27.2	29.5	32.9	35.6	
KBL 21 P	21	2.15	2.66	4.20	6.80	9.37	11.7	14.5	17.5	19.5	20.8	23.0	26.3	33.6	36.4	40.7	44.0	
KBL 32 P	32	3.27	4.05	6.40	10.4	14.3	17.8	22.2	26.7	29.7	31.7	35.0	40.0	51.2	55.4	62.0	67.1	
KBL 38 P	38	3.89	4.81	7.60	12.3	17.0	21.2	26.3	31.7	35.3	37.6	41.6	47.5	60.8	65.8	73.6	79.6	
KBL 46 P	46	4.71	5.83	9.20	14.9	20.5	25.6	31.9	38.3	42.7	45.6	50.3	57.6	73.6	79.7	89.1	96.4	
KBL 50 P	50	5.16	6.35	10.0	16.2	22.3	27.7	33.8	40.8	45.5	48.7	53.4	61.0	77.9	84.0	94.7	98.0	
KBL 64 P	64	6.56	8.10	12.8	20.7	28.5	35.4	43.3	52.2	58.2	62.2	68.3	78.1	99.7	108	121	125	
KBL 73 P	73	7.54	9.28	14.6	23.6	32.5	40.5	49.4	59.5	66.4	71.0	78.0	89.1	114	123	138	143	
KBL 80 P	80	8.26	10.1	16.0	25.9	35.6	44.3	54.1	65.2	72.8	77.8	85.4	97.6	125	134	152	157	
KBL 90 P	90	9.29	11.4	18.0	29.1	40.1	50.0	60.9	73.4	81.9	87.5	96.1	110	140	152	171	176	
KBL 102 P	102	10.5	13.0	20.4	33.0	45.5	56.8	70.7	85.0	94.7	101	112	128	163	177	198	213	
KBL 118 P	118	12.2	14.9	23.6	38.2	52.6	65.5	79.8	96.2	107	115	126	144	184	198	224	231	
KBL 128 P	128	13.2	16.3	25.6	41.5	57.1	71.3	88.7	107	119	127	140	160	205	222	248	268	
KBL 140 P	140	14.5	17.7	28.0	45.3	62.4	77.8	94.7	114	127	136	149	171	218	235	266	274	
KBL 155 P	155	16.0	19.6	31.0	50.2	69.0	86.1	105	126	141	151	166	189	242	261	294	304	
KBL 173 P	173	17.9	22.0	34.6	56.0	77.1	96.1	117	141	157	168	185	211	270	292	329	339	
KBL 200 P	200	20.7	25.4	40.0	64.7	89.1	111	135	163	182	194	214	244	312	336	379	392	
KBL 214 P	214	22.1	27.2	42.8	69.3	95.3	119	145	175	195	208	229	261	333	361	406	420	
KBL 220 P	220	22.5	28.0	44.0	71.2	98.0	122	149	179	200	214	236	269	343	370	417	431	
KBL 256 P	256	26.4	32.5	51.2	82.8	114	142	173	209	233	249	273	312	399	431	486	502	
KBL 280 P	280	28.9	35.6	56.0	90.6	125	156	189	228	255	272	299	342	436	471	530	549	
KBL 304 P	304	31.4	38.7	60.8	98.4	135	169	206	248	277	296	325	371	473	512	577	596	
KBL 320 P	320	33.0	40.7	64.0	104	143	178	216	261	291	311	342	391	499	538	606	627	
KBL 346 P	346	35.7	44.0	69.2	112	154	192	234	282	315	336	369	422	539	582	656	678	
KBL 360 P	360	37.2	45.8	72.0	117	160	200	243	294	328	350	384	439	561	605	682	706	
KBL 390 P	390	40.3	49.6	78.0	126	174	217	264	318	355	379	416	476	607	657	740	765	
KBL 400 P	400	41.3	50.9	80.0	129	178	222	270	326	364	389	427	488	623	672	758	784	
KBL 429 P	429	44.3	54.5	85.8	139	191	238	290	350	390	417	458	523	668	722	814	841	
KBL 450 P	450	46.5	57.2	90.0	146	200	250	304	367	410	438	481	549	701	756	853	882	
KBL 465 P	465	48.0	59.1	93.0	150	207	258	314	379	423	452	497	567	724	783	882	912	
KBL 490 P	490	50.6	62.3	98.0	159	218	272	331	400	446	476	523	598	764	824	928	961	
KBL 510 P	510	52.7	64.8	102	165	227	283	345	416	464	496	545	622	794	859	968	1000	
KBL 535 P	535	55.2	68.0	107	173	238	297	362	436	487	520	571	653	834	899	1014	1049	
KBL 570 P	570	58.9	72.5	114	184	254	317	385	465	519	554	609	696	888	958	1080	1117	
KBL 585 P	585	60.4	74.4	117	189	261	325	396	477	532	569	625	713	911	985	1110	1147	
KBL 620 P	620	64.0	78.8	124	201	276	344	419	506	564	603	662	757	966	1042	1175	1215	
KBL 645 P	645	66.6	82.0	129	209	287	358	436	526	587	627	689	787	1004	1086	1224	1265	
KBL 675 P	675	69.7	85.8	135	218	301	375	456	550	614	656	721	824	1052	1135	1279	1323	
KBL 700 P	700	71.6	89.0	140	227	312	388	473	571	637	681	747	854	1090	1177	1327	1372	
KBL 770 P	770	79.5	97.9	154	249	343	428	520	628	701	749	822	939	1199	1296	1461	1509	
KBL 800 P	800	82.6	102	160	259	356	444	541	652	728	778	854	976	1247	1345	1516	1568	
KBL 830 P	830	85.7	106	166	269	370	461	561	677	755	807	886	1013	1293	1395	1572	1627	
KBL 860 P	860	88.8	109	172	278	383	476	581	701	783	836	918	1050	1339	1448	1632	1686	
KBL 920 P	920	95.0	117	184	298	410	511	622	750	837	895	982	1123	1434	1546	1743	1803	
KBL 970 P	970	100	123	194	314	432	537	656	791	883	943	1036	1184	1511	1630	1839	1901	
KBL 1020 P	1020	105	130	204	330	454	566	689	832	928	992	1089	1244	1588	1717	1935	2000	
KBL 1040 P	1040	107	132	208	337	463	578	703	848	947	1011	1111	1269	1621	1748	1970	2039	
KBL 1070 P	1070	110	136	214	346	477	594	723	873	974	1040	1143	1305	1666	1802	2030	2098	
KBL 1140 P	1140	118	145	228	369	508	633	771	930	1038	1109	1217	1391	1776	1916	2160	2235	
KBL 1220 P	1220	126	155	244	395	543	678	825	995	1110	1186	1303	1489	1901	2051	2311	2392	
KBL 1240 P	1240	128	158	248	401	552	689	838	1011	1129	1206	1324	1513	1932	2084	2349	2431	
KBL 1280 P	1280	132	163	256	414	570	711	865	1044	1165	1245	1367	1561	1993	2155	2428	2510	
KBL 1320 P	1320	136	168	264	427	588	731	893	1077	1201	1284	1410	1612	2057	2218	2503	2586	
KBL 1360 P	1360	140	173	272	440	606	755	920	1109	1238	1322	1452	1660	2119	2286	2576	2666	
KBL 1400 P	1400	145	178	280	453	624	778	946	1142	1274	1361	1495	1707	2179	2357	2656	2745	
KBL 1480 P	1480	153	188	296	479	659	820	1001	1207	1347	1439	1580	1807	2305	2487	2806	2900	
KBL 1540 P	1540	159	196	308	498	686	855	1041	1256	1402	1497	1644	1878	2397	2593	2922	3020	

BATTERY RACK DIMENSIONS

For safe and reliable operation, batteries should be mounted on suitable battery racks. HBL battery racks are made of alkali-resistant, powder coated steel sections. Battery racks are available in multi-step one tier or multi-step two tier configuration. Standard battery racks are supplied in knocked-down condition and can be easily assembled at site.

Container size reference	1Tier								2Tier							
	1STEP		2STEP		3STEP		4STEP		1STEP		2STEP		3STEP		4STEP	
	W	H	W	H	W	H	W	H	W	H	W	H	W	H	W	H
(Normal arrangement)																
B21-1/B22-1 B23-1/B24-1			296	703	434	818	572	933			296	1250	434	1450	572	1700
B31-1/B31B-1 B32-1/B33-1			440	788	650	903	860	1018			440	1400	650	1620	860	1850
B41-1/B41B-1 B42-1/B42A-1 B44-1/B45-1			440	844	650	959	860	1074			440	1550	650	1800	860	2050
(Cross-wise arrangement)																
B31-2			416	788	614	903	812	1018			416	1400	614	1620	812	1850
B31-3			586	788	869	903					586	1400	869	1620		
B31-4			754	788							754	1400				
B31-5			924	788					472	1160	924	1400				
B31B-2			368	788	542	903	716	1018			368	1400	542	1620	716	1850
B31B-3			514	788	761	903					514	1400	761	1620		
B31B-4			658	788	977	903					658	1400	977	1620		
B31B-5			804	788							804	1400				
B32-2			304	788	446	903	588	1018			304	1400	446	1620	588	1850
B41-2			416	844	614	959	812	1074			416	1550	614	1800	812	2050
B41-3			586	844	869	959					586	1550	869	1800		
B41-4			754	844							754	1550				
B41-5			924	844					472	1320	924	1550				
B41-6	557	729	1094	844					557	1320						
B41B-2			368	844	542	959	716	1074			368	1550	542	1800	716	2050
B41B-3			514	844	761	959					514	1550	761	1800		
B41B-4			658	844	977	959					658	1550	977	1800		
B41B-5			804	844							804	1550				
B42A-2			290	884	425	959	560	1074			290	1550	425	1800	560	2050
B42-2			304	884	446	959	588	1074			304	1550	446	1800	588	2050
B42-6			782	884							782	1550				

(All dimensions in mm)

Calculation of length :

Length of rack = (X + 5) x No. of block cells in a row (for all block cells)

Where X = Length of cell / Block cell for Row-wise mounting (i.e. for B21-1, B22-1, B23-1, B24-1, B31-1, B31B-1, B32-1, B33-1, B41-1, B41B-1, B42-1, B42A-1, B44-1, B45-1)

= width of Cell / Block cell for Cross-wise mounting (i.e. for B31 / 31B / 32 / 41 / 41B / 42A / 42-2 / 3 / 4 / 5 / 6)

The value of length should be rounded-off to nearest to 50 mm and 5mm should be added.

Standard arrangement of cells on racks :

Arrangement	KBH	KBM	KBL
Normal	9 to 118	12 to 231	8 to 256
Crosswise	127 to 930	277 to 1460	280 to 1540

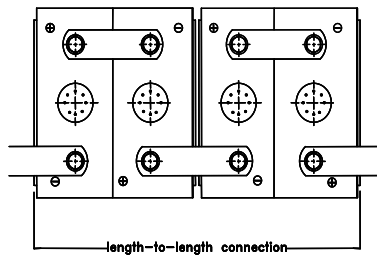

NORMAL ARRANGEMENT

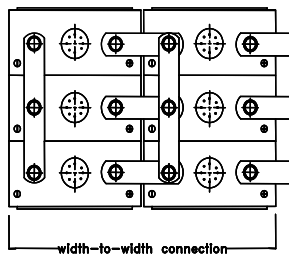

CROSS WISE ARRANGEMENT

Optional Items :

(To be supplied on request)

1. Cubicles in place of racks
2. Low electrolyte level / alarm
3. Containers in structural foam molded polypropylene
4. Stainless / Wooden / HDPE crates for cells
5. Recombination vents

SINGLE TIER RACKS
2STEP 1TIER RACK

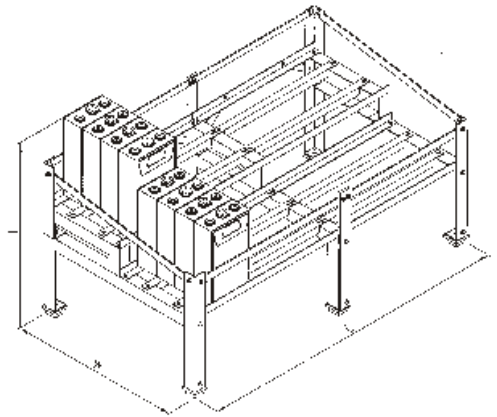

SINGLE TIER RACKS
3STEP 1TIER RACK

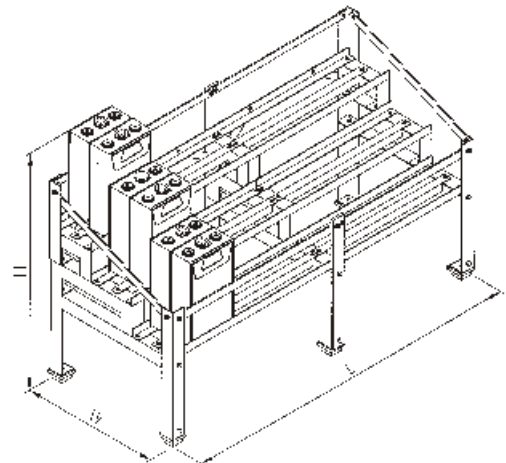

SINGLE TIER RACKS
4STEP 1TIER RACK

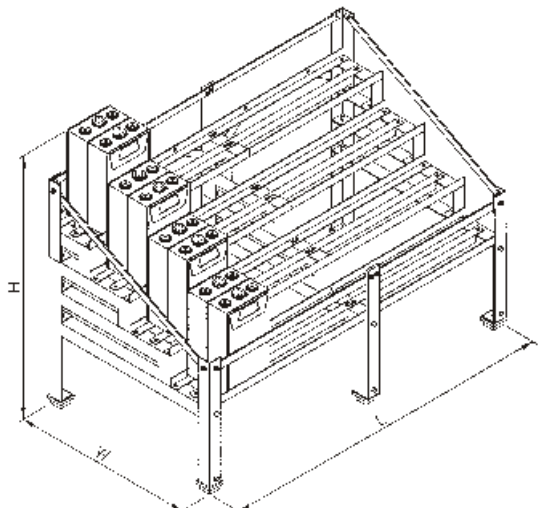

TWO TIER RACKS
1STEP 2TIER RACK

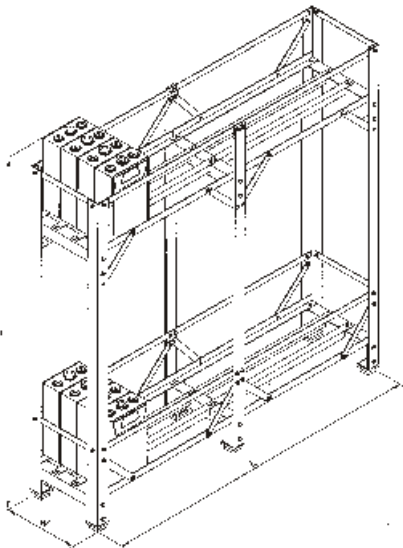

TWO TIER RACKS
2STEP 2TIER RACK

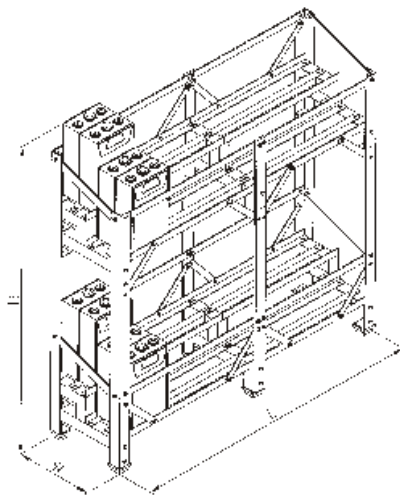

TWO TIER RACKS
3STEP 2TIER RACK

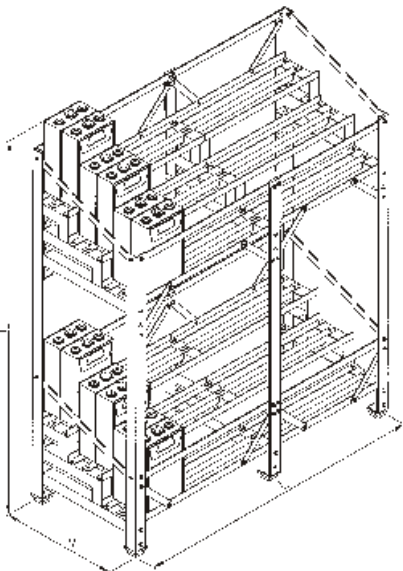

TWO TIER RACKS
4STEP 2TIER RACK

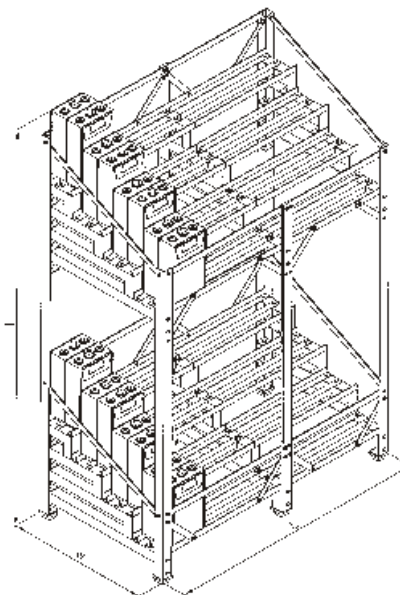

Typical Characteristics

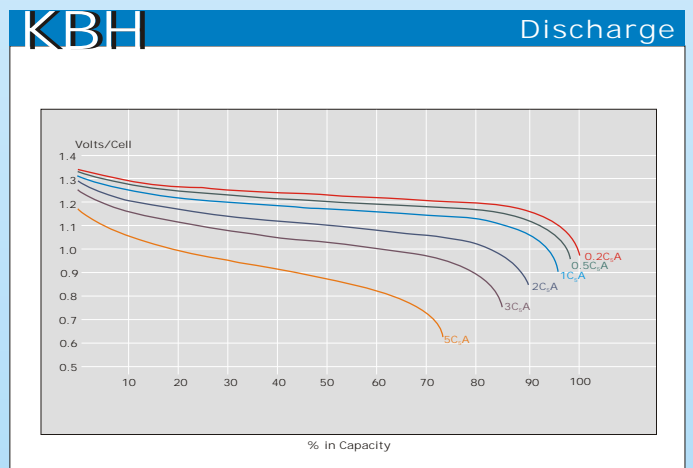
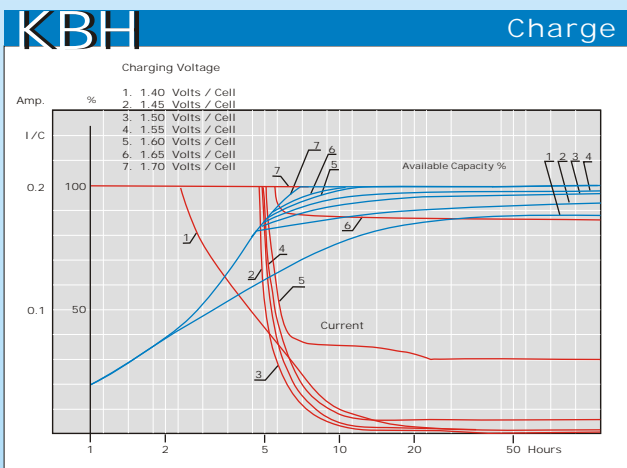
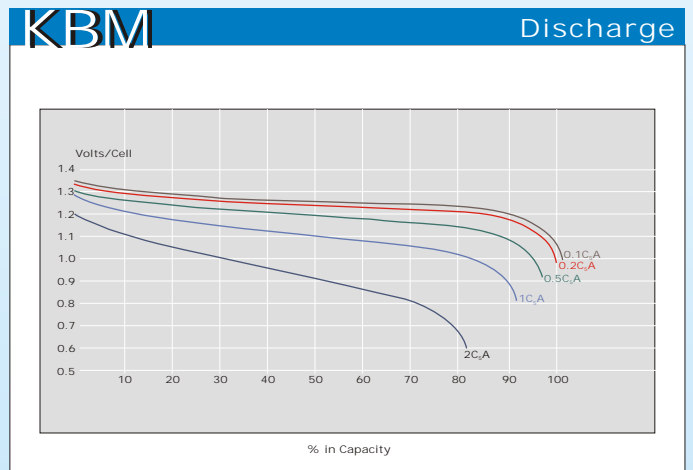
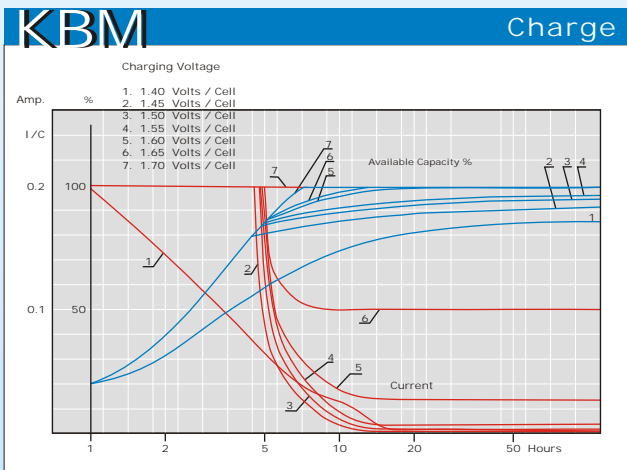
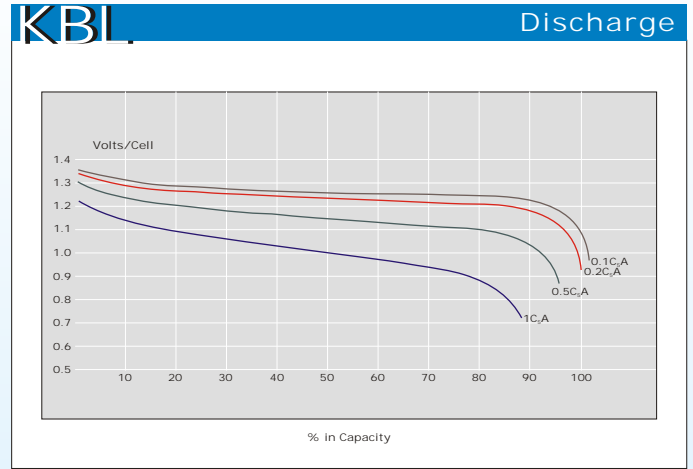
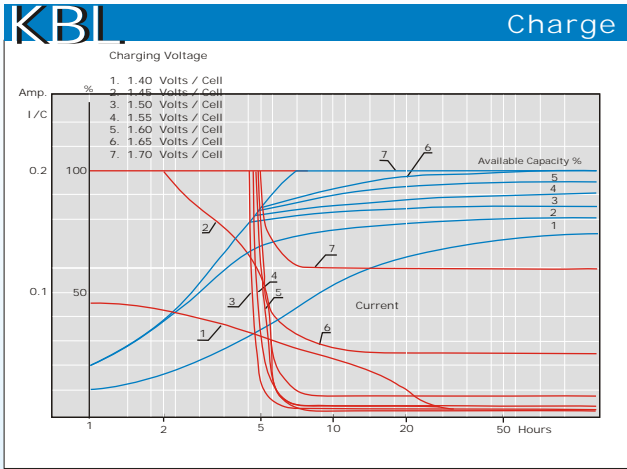



HBL Power Systems Limited

Road # 10, Banjara Hills, Hyderabad - 500 034. INDIA
E-mail: contact@hbl.in
www.hbl.in