

TELECOM RANGE

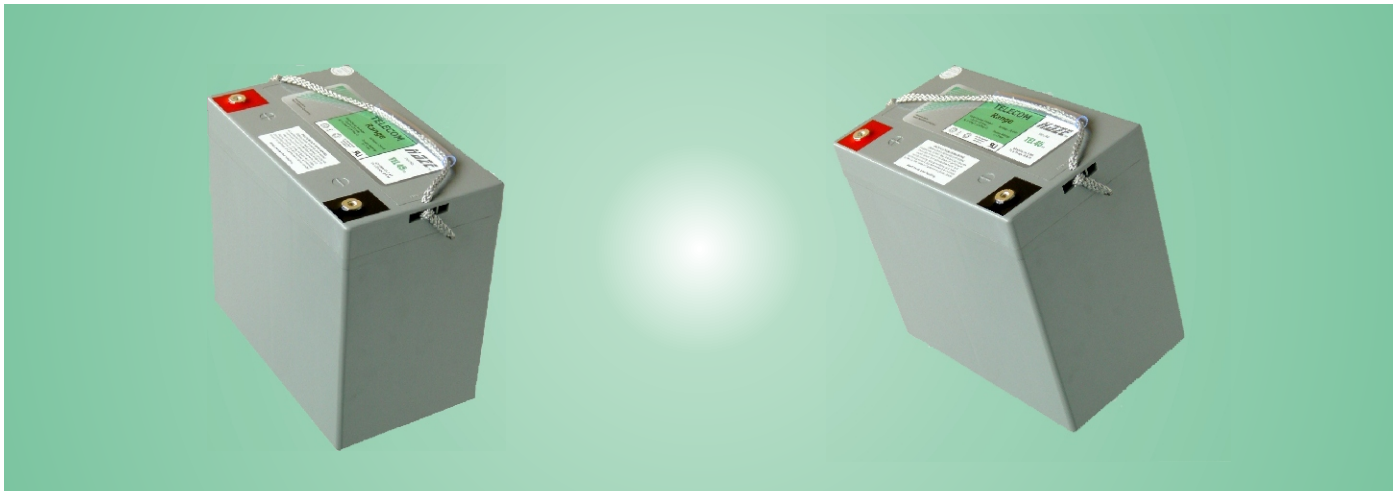

Model No. TEL 45 (12 Volts, 49.8 Ah at 8 hour Rate to 1.75 vpc)
Valve Regulated Lead Acid Battery for communications
standby power applications

Innovative Features

- ◆ Completely maintenance free, sealed construction eliminates the need for watering
- ◆ Fully tank formed plates
- ◆ Analytical Grade electrolyte
- ◆ Spill proof / leak proof
- ◆ Valve regulated Max internal pressure 2.5 psi
- ◆ Multi-position usage
- ◆ ABS Case & Cover Flame Retardant meets UL 94 VO requirements
- ◆ Low self discharge
- ◆ FAA and IATA approved as non-hazardous
- ◆ Designed to comply with Bellcore TR-NWT-000766, Bellcore TR-NWT-000909, ANSI T1.330-1997, Telcordia SR 4228, British Standard BS 6290 Part 4, IEC 896 Part 2, Eurobat, DIN 43534
- ◆ UL Recognized, ISO 9001

Ampere Hour Capacity at 77°F (25°C) to 1.75 vpc

Discharge Time in Hrs	1	2	3	4	5	6	7	8	10
Ampere Hour Capacity	34.7	37.7	39.9	42.2	44.3	46.0	48.0	49.8	51.9

Website: www.hazebattery.com/usa
E mail : customerservice@hazebattery.com
Ph: 952-746-7528 Fax: 952-746-7527



Sealed Lead Acid 12 Volt Bloc AGM Range

Specifications

Nominal Voltage		12V	
Nominal Capacity		57.9 Ah	
Dimensions	Total Height (Inc terminals)	8.15 inches	207 mm
	Length	n/a	n/a
	Width	8.98 inches	228 mm
	Weight	5.39 inches	137 mm
	Weight	38.68 lbs	17.5 Kg



Haze Battery Company Ltd

Characteristics

Capacity 77°F (25°C) to 1.75 vpc	20 hour rate	57.9 Ah
	10 hour rate	51.9 Ah
	5 hour rate	44.3 Ah
	2 hour rate	37.7 Ah
	1 hour rate	34.7 Ah
	Internal Resistance	6.5 mOhms
Capacity correction for temperature Variations (C20)	104°F (40°C)	102%
	68°F (20°C)	100%
	32°F (0°C)	85%
	5°F (-15°C)	65%
Self Discharge 77°F (25°C)	Capacity after 1 month storage	98%
	Capacity after 3 months storage	94%
	Capacity after 6 months storage	86%
Short Circuit Current 77°F (25°C)	1700	
Terminal	Standard	14mm Insert M6 thread
Charging (Constant Voltage)	Float	2.27 - 2.30 vpc (59 - 77°F)

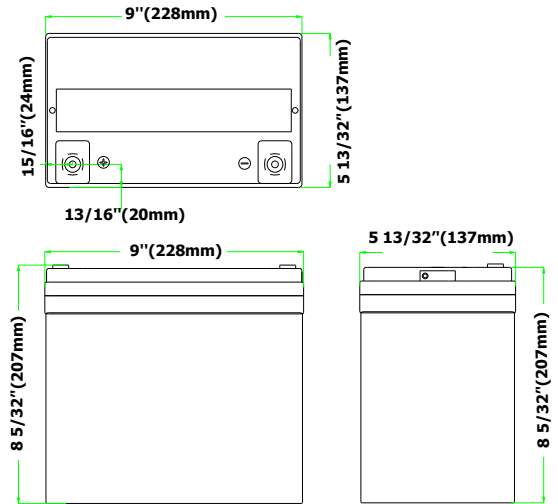

End V per Cell	Ampere Hour at 77°F (25°C)									
	1 hr	2 hr	3 hr	4 hr	5 hr	8 hr	10 hr	12 hr	20 hr	
1.85	33.1	36.2	38.2	40.3	42.2	47.4	49.6	51.1	55.1	
1.80	34.2	37.2	39.2	41.4	43.4	48.8	51.0	52.6	56.8	
1.75	34.7	37.7	39.9	42.2	44.3	49.8	51.9	53.5	57.9	
1.70	35.3	38.4	40.6	43.0	45.2	50.6	52.9	54.5	59.1	

Constant Amps Discharge - Amps at 77°F (25°C)										
1.85	33.10	18.10	12.70	10.08	8.45	5.92	4.96	4.26	2.76	
1.80	34.20	18.60	13.10	10.36	8.68	6.09	5.10	4.39	2.84	
1.75	34.70	18.90	13.30	10.56	8.87	6.22	5.19	4.46	2.90	

Specifications

Design Life	12 Years
Operating Temperature	-4 °F to 122 °F
Grid alloy	Calcium / Tin lead alloy
Plates	Flat Pasted
Separator	Absorbant Glass Mat
Active material	Very high purity lead
Charge Voltage	Float 2.25 - 2.30 VPC @77 °F Cycling 2.35 @77 °F Max. 2.4 VPC Max ripple 0.05C (A)
Electrolyte	Sulphuric acid Analytical grade purity
Venting Valve	EPDM Rubber 1.5 to 2 psi (10.5 - 14 KPa) release pressure. Resealing at 1 psi (7 KPa)
Torque setting	The recommended torque value for all types is 44-62 inch-pounds

Terminal Details

Insert are made from brass with copper, nickel and silver plating giving excellent mechanical, electrical and corrosion resistant properties.

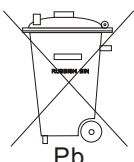

Haze Battery Company keenly encourages environmental awareness; PLEASE follow guidelines for the recycling /disposal of lead.



UL Recognised
Component
MH 20947

