

TELECOM RANGE

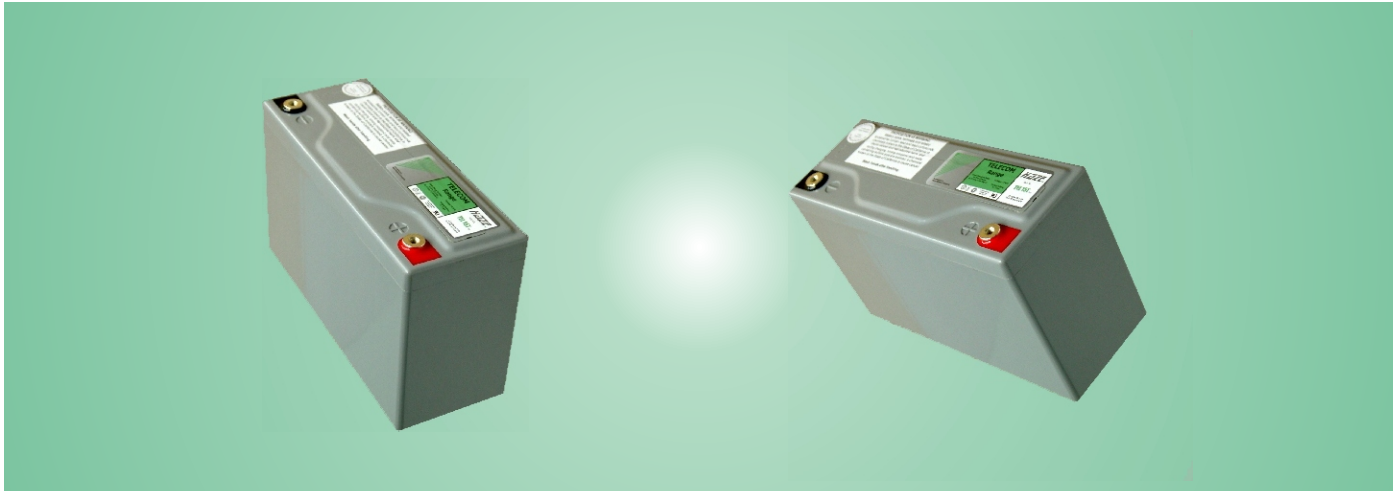

Model No. TEL 15T (12 Volts, 15.1 Ah at 8 hour Rate to 1.75 vpc)
Valve Regulated Lead Acid Battery for communications
standby power applications

Innovative Features

- ◆ Completely maintenance free, sealed construction eliminates the need for watering
- ◆ Fully tank formed plates
- ◆ Analytical Grade electrolyte
- ◆ Spill proof / leak proof
- ◆ Valve regulated Max internal pressure 2.5 psi
- ◆ Multi-position usage
- ◆ ABS Case & Cover Flame Retardant meets UL 94 VO requirements
- ◆ Low self discharge
- ◆ FAA and IATA approved as non-hazardous
- ◆ Designed to comply with Bellcore TR-NWT-000766, Bellcore TR-NWT-000909, ANSI T1.330-1997, Telcordia SR 4228, British Standard BS 6290 Part 4, IEC 896 Part 2, Eurobat, DIN 43534
- ◆ UL Recognized, ISO 9001

Ampere Hour Capacity at 77°F (25°C) to 1.75 vpc

Discharge Time	15 mins	30 mins	1 hr	2 hrs	4 hrs	8 hrs	10 hrs	20 hrs
Ampere Hour Capacity	7.4	9.3	10.8	12.6	13.9	15.1	15.1	16.9

Website: www.hazebattery.com/usa
E mail : customerservice@hazebattery.com
Ph: 952-746-7528 Fax: 952-746-7527



Sealed Lead Acid 12 Volt Bloc AGM Range

Specifications

Nominal Voltage		12V	
Nominal Capacity		16.9 Ah	
Dimensions	Total Height (Inc terminals)	4.84 inches	123 mm
	Length	7.87 inches	200 mm
	Width	2.99 inches	76 mm
	Weight	11.36 lbs	5.14 Kg



Haze Battery Company Ltd

Characteristics

Capacity 77°F (25°C) to 1.75 vpc	20 hour rate	16.9 Ah
	10 hour rate	15.1 Ah
	4 hour rate	13.9 Ah
	1 hour rate	10.8 Ah
	15 min rate	7.4 Ah
	Internal Resistance	18 mOhms
Capacity correction for temperature Variations (C20)	104°F (40°C)	102%
	68°F (20°C)	100%
	32°F (0°C)	85%
	5°F (-15°C)	65%
Self Discharge 77°F (25°C)	Capacity after 1 month storage	98%
	Capacity after 3 months storage	94%
	Capacity after 6 months storage	86%
Short Circuit Current 77°F (25°C)	750	
Terminal	Standard	12mm Insert M5 thread
Charging (Constant Voltage)	Float	2.27 - 2.30 vpc (59 - 77°F)

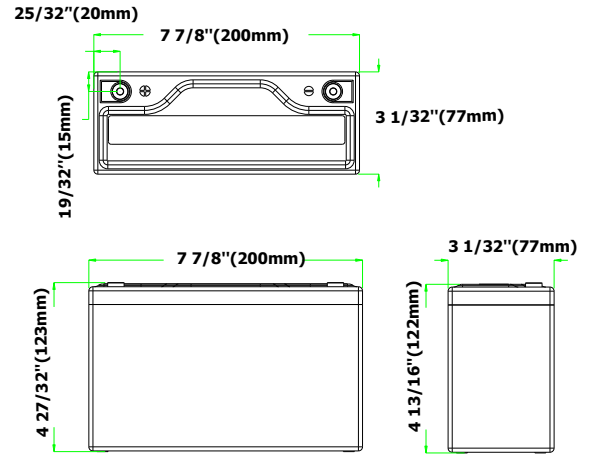

End V per Constant Amps Discharge - Amps at 77°F (25°C)

Cell	15 mins	30 mins	1 hr	2 hrs	4 hrs	8 hrs	10 hrs	20 hrs
1.85	27.00	17.30	10.20	5.93	3.31	1.82	1.50	0.80
1.80	28.90	18.10	10.60	6.14	3.41	1.87	1.54	0.83
1.75	29.90	18.60	10.80	6.28	3.47	1.89	1.56	0.84

Specifications

Design Life	12 Years
Operating Temperature	-4 °F to 122 °F
Grid alloy	Calcium / Tin lead alloy
Plates	Flat Pasted
Separator	Absorbant Glass Mat
Active material	Very high purity lead
Charge Voltage	Float 2.25 - 2.30 VPC @77 °F Cycling 2.35 @77 °F Max. 2.4 VPC Max ripple 0.05C (A)
Electrolyte	Sulphuric acid Analytical grade purity
Venting Valve	EPDM Rubber 1.5 to 2 psi (10.5 - 14 KPa) release pressure. Resealing at 1 psi (7 KPa)
Torque setting	The recommended torque value for all types is 44-62 inch-pounds

Terminal Details

Insert are made from brass with copper, nickel and silver plating giving excellent mechanical, electrical and corrosion resistant properties.

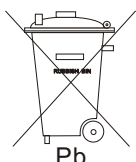

Haze Battery Company keenly encourages environmental awareness; PLEASE follow guidelines for the recycling /disposal of lead.



UL Recognised
Component
MH 20947

