

TELECOM RANGE



Model No. TEL 105F (12 Volts, 102 Ah at 8 hour Rate to 1.75 vpc)
Valve Regulated Lead Acid Battery for communications
standby power applications

Innovative Features

- ◆ Completely maintenance free, sealed construction eliminates the need for watering
- ◆ Fully tank formed plates
- ◆ Analytical Grade electrolyte
- ◆ Spill proof / leak proof
- ◆ Valve regulated Max internal pressure 2.5 psi
- ◆ Multi-position usage
- ◆ ABS Case & Cover Flame Retardant meets UL 94 VO requirements
- ◆ Low self discharge
- ◆ FAA and IATA approved as non-hazardous
- ◆ Designed to comply with Bellcore TR-NWT-000766, Bellcore TR-NWT-000909, ANSI T1.330-1997, Telcordia SR 4228, British Standard BS 6290 Part 4, IEC 896 Part 2, Eurobat, DIN 43534
- ◆ UL Recognized, ISO 9001

Ampere Hour Capacity at 77°F (25°C) to 1.75 vpc

Discharge Time in Hrs	1	2	3	4	5	6	7	8	10
Ampere Hour Capacity	65.6	75.2	82.5	88.2	93.1	96.9	99.8	102.0	104.0

Website: www.hazebattery.com/usa
E mail : customerservice@hazebattery.com
Ph: 952-746-7528 Fax: 952-746-7527



AGM Range
Sealed Lead Acid 12 Volt Bloc

Specifications

Nominal Voltage		12V	
Nominal Capacity		113 Ah	
Dimensions	Total Height (Inc terminals)	8.86 inches n/a	225 mm n/a
	Length	19.88 inches	505 mm
	Width	4.33 inches	110 mm
	Weight	66.30 lbs	30 Kg



Haze Battery Company Ltd

Characteristics

Capacity 77°F (25°C) to 1.75 vpc	20 hour rate	113 Ah
	10 hour rate	104 Ah
	5 hour rate	93.1 Ah
	2 hour rate	75.2 Ah
	1 hour rate	65.6 Ah
	Internal Resistance	3.7 mOhms
Capacity correction for temperature Variations (C20)	104°F (40°C)	102%
	68°F (20°C)	100%
	32°F (0°C)	85%
	5°F (-15°C)	65%
Self Discharge 77°F (25°C)	Capacity after 1 month storage	98%
	Capacity after 3 months storage	94%
	Capacity after 6 months storage	86%
Short Circuit Current 77°F (25°C)	3300	
Terminal	Standard	14mm Insert M6 thread
Charging (Constant Voltage)	Float	2.27 - 2.30 vpc (59 - 77°F)

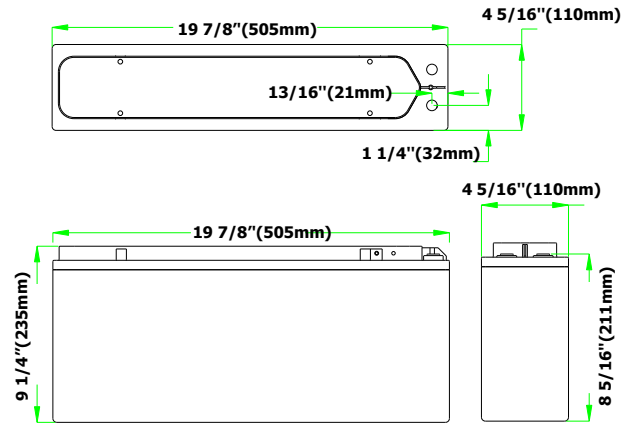

End V per

Ampere Hour at 77°F (25°C)

Cell	1 hr	2 hr	3 hr	4 hr	5 hr	8 hr	10 hr	12 hr	20 hr
1.83	62.9	72.8	80.2	86.0	90.8	98.7	101.0	104.0	110.0
1.80	64.7	74.5	81.6	87.4	92.3	101.0	103.0	105.0	112.0
1.75	65.6	75.2	82.5	88.2	93.1	102.0	104.0	106.0	113.0
1.70	66.2	75.9	83.2	88.9	93.8	102.0	105.0	107.0	114.0

Constant Amps Discharge - Amps at 77°F (25°C)

1.83	62.90	36.40	26.70	21.50	18.20	12.30	10.10	8.63	5.52
1.80	64.70	37.30	27.20	21.90	18.50	12.60	10.30	8.78	5.61
1.75	65.60	37.60	27.50	22.10	18.60	12.70	10.40	8.87	5.67

Specifications

Design Life	12 Years
Operating Temperature	-4 °F to 122 °F
Grid alloy	Calcium / Tin lead alloy
Plates	Flat Pasted
Separator	Absorbant Glass Mat
Active material	Very high purity lead
Charge Voltage	Float 2.25 - 2.30 VPC @77 °F Cycling 2.35 @77 °F Max. 2.4 VPC Max ripple 0.05C (A)
Electrolyte	Sulphuric acid Analytical grade purity
Venting Valve	EPDM Rubber 1.5 to 2 psi (10.5 - 14 KPa) release pressure. Resealing at 1 psi (7 KPa)
Torque setting	The recommended torque value for all types is 44-62 inch-pounds

Terminal Details

Insert are made from brass with copper, nickel and silver plating giving excellent mechanical, electrical and corrosion resistant properties.

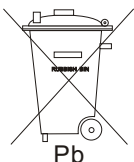

Haze Battery Company keenly encourages environmental awareness; PLEASE follow guidelines for the recycling /disposal of lead.



UL Recognized
Component
MH 20947

