

BROAD-BAND SERIES



BBG-180RT

VALVE REGULATED LEAD ACID BATTERY
FOR BROADBAND STANDBY POWER APPLICATIONS

FEATURES & BENEFITS

- Flame-arresting one-way pressure-relief vent for safety and long life.
- Thermally welded case-to-cover bond to ensure a leak-proof seal.
- Thick positive plate design for maximum service float life.
- Case and cover of high-impact polypropylene with reinforced endwalls to reduce bulging.
- Removable carrying handles.
- Gas recombination efficiency of up to 99% for freedom from electrolyte maintenance.
- Designed to meet full published ratings at initial start-up installation
- Multicell design for ease of installation and maintenance.
- UL-recognized component.
- Gelled electrolyte for superior float service life and thermal management.

12 Volts - 94 Ampere Hour Capacity @ 20 Hour Rate

Ampere Hour Capacity to 1.75 Volts per Cell @ 77°F (25°C)

Discharge in Hours	.25	.50	1.00	2.00	3.00	4.00	5.00	6.00	7.00	8.00	10.00	12.00	20.00	24.00	48.00	72.00	100.00
Amp-Hr Capacity	39.5	50.5	61.2	70.4	75.6	78.8	82.0	83.4	85.4	86.4	88.9	89.9	93.6	95.0	99.8	102	103

BBG-180RT - Specifications

Cells Per Unit	Voltage Per Unit	Weight	Maximum Discharge Current	Short Circuit Current	Ohms Imped. 60 Hz (Ω)
6	12.84	66 lbs. (30 kg)	800 Amps	2500 Amps @ 0.1 sec	0.0050 Ohms

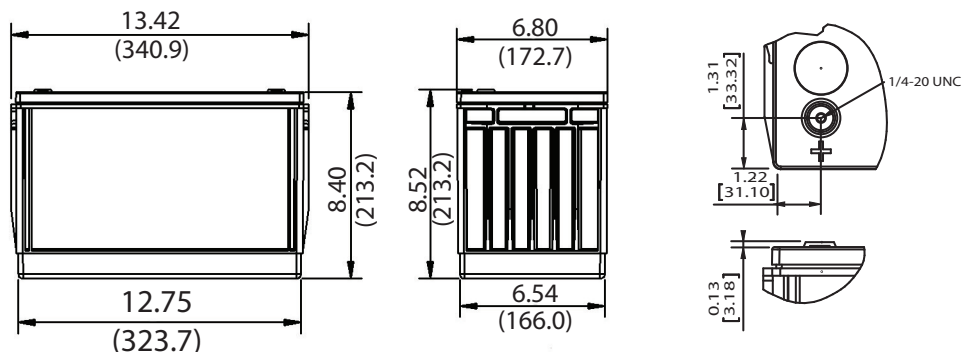

All dimensions in inches and (millimeters). All dimensions are for reference only. Contact a C&D Representative for complete dimensional information.

Capacity	93.6 Ah @ 20 hour rate to 1.75 volts per cell @ 77°F (25°C)
Operating Temperature Range	Discharge; -40°F (-40°C) to + 160°F (71°C), Charge; -10°F (-23°C) to+ 140°F (60°C) with temperature compensation
Recommended Operating Temperature Range	+ 74°F (23°C) to +80°F (27°C)
Float Charging Voltage	13.5 to 13.8 VDC/unit Average at 77°F (25°C)
Recommended Maximum Charging Current Limit	C ₂₀ /5 amperes 18.8 amperes
Maximum AC Ripple (Charger)	0.5 % RMS or 1.5% P-P of float charge voltage recommended for best results. Maximum AC ripple voltage allowed = 1.4% RMS (4% P-P) Maximum AC ripple current allowed = 4.7 amperes RMS (C ₂₀ /20)
Self Discharge	Broadband batteries may be stored for up to 6 months at 77°F (25°C) and then a freshening charge is required. For higher temperatures the time interval will be shorter.
Accessories	Inter unit connectors, and racks are available.
Terminal	Threaded copper alloy insert terminal to accept 1/4-20 UNC bolt
Terminal Hardware Torque	110 in.-lbs. (12.4 n-m).

Constant Current Discharge Ratings - Amperes @ 77°F (25°C) to 1.75 Volts per cell

Amperes	5	10	15	20	25	30	35	40	45	50
Run Time (Minutes)	1118	524	331	237	182	146	121	102	88	78

Constant Current Discharge Ratings - Amperes @ 77°F (25°C)

Operating Time to End Point Voltage (in hours)

End Point Volts/Cell	.25	.50	1.00	2.00	3.00	4.00	5.00	6.00	7.00	8.00	10.00	12.00	20.00	24.00	48.00	72.00	100
1.75	158	101	61.2	35.2	25.2	19.7	16.4	13.9	12.2	10.8	8.89	7.49	4.68	3.96	2.08	1.42	1.03
1.80	145	95.7	59.4	34.6	24.8	19.5	16.2	13.8	12.0	10.7	8.78	7.40	4.62	3.90	2.04	1.39	1.02
1.85	127	87.5	56.0	33.2	24.0	18.9	15.7	13.3	11.7	10.4	8.51	7.17	4.46	3.77	1.97	1.34	0.98
1.90	107	75.6	50.0	30.5	22.2	17.6	14.6	12.5	10.9	9.71	7.96	6.70	4.16	3.51	1.82	1.23	0.90

Note: Batteries to be mounted with 0.5 in. (12.5 mm) spacing minimum and free air ventilation. Specifications subject to change without notification.